



# Board of Building Standards

## CERTIFICATION COMMITTEE MEETING AGENDA **(REVISED 9/20/22)**

DATE: SEPTEMBER 22, 2022  
TIME: 10:00 AM  
LOCATION: TRAINING ROOM 3, 6606 TUSSING ROAD, REYNOLDSBURG, OHIO  
[Click here to join the meeting](#)

### Call to Order

### Consent Agenda

### Personnel Certification Applications

#### P-1

Plaza-Serrano, Saul - BO

Cert ID: 1177

Current Certifications: BI, RBO

Staff Notes: Previously held BO interim, did not complete exams, denied in 2017 for recertification. Attending meeting to discuss testing history, plan for future exams.

Committee Recommendation:

#### P-2

Seikel, Tim BI - Additional Information

Certification ID# 8893

Current certifications- none

Staff notes- All experience is as property insurance claims adjuster, with in person inspections of claims. Additional information requested at August 25 meeting: applicant will appear at meeting.

Committee recommendations-

#### P-3

May, Terrence RBI

Certification ID# 8921

Current certifications- none

Staff notes-Unusual experience, review for equivalence. Attending meeting to discuss application.

Committee recommendation:

#### P-4

Furry, Mark ESI Trainee - Alternative Trainee Plan

Certification ID# 8882

Current certifications- none

Staff notes-Approved for exams August 2022. Alternative trainee plan provides for study time and appropriate supervision, terminating upon completion of exams and Code Academy. Recommend approval.

Committee recommendation:

- P-5 Holbert Jr., Harry - BI, RBO  
Cert ID: 4776  
Current Certifications: None, previously held BI, FPI, RBO  
Staff Notes: In communication with applicant, as application does not agree with cover letter as to certifications requested.  
Committee Recommendation:
- P-6 Losekamp, Kenneth ESI  
Certification ID# 8915  
Current certifications- BI, RBI  
Staff notes-Unclear whether he performed the work listed: request for clarification sent 9/13  
ESIAC Recommendations: Need additional information on work performed.  
Committee recommendation:
- P-7 Prescott, Aaron - ESI Trainee, Alternative Trainee Program  
Cert ID: 8933  
Current Certifications: None  
Staff Notes: Alternative trainee plan tailored to meet applicant's needs to be successful as an ESI. Recommend approval.  
Committee Recommendations:
- P-8 Sanson, Joseph RBO  
Certification ID# 8928  
Current certifications- none  
Staff notes: Need additional information on PE status, work listed on application.  
Request sent via email 9/13  
Committee recommendation:
- P-9 Grusenmeyer, Jeffrey - ESI, PI, BI  
Cert ID: 568  
Current Certifications: BO, MPE, RBO  
Staff Notes: As discussed at August 25 meeting, applicant has decades of experience designing all building systems and inspecting installation for owner approval.  
Recommend approval  
Committee recommendation:
- P-10 Neff, Matthew - ESI  
Cert ID:  
Current Certifications: None  
Staff notes: Requested journeyman card, electrical contractor's license via email 9/19  
Committee Recommendation:

## **Building Department Certification Applications**

### **Old Business**

**New Business**

- NB-1 Certification Application Modernization Project  
Board staff have begun to examine the current certification application and application approval process to find ways to eliminate some requests for additional information and generate more applicant success in the first round of review, applying LEAN concepts. Updated applications will be brought to the committee as they are developed.
  
- NB-2 Trainee MPE when employed by architectural firm or engineering firm  
Recently, staff has fielded a few questions about the possibility of entering into a trainee program when the applicant is employed by an architectural firm and the applicant and supervisor are performing plans examinations by contract for one or more jurisdictions. Committee recommendation:

**Adjourn**

**CERTIFICATION COMMITTEE MEETING  
CONSENT AGENDA**

**Certification Applications**

- C-1 Ashley, Alan - BO  
Certification ID# 5783  
Current certifications- BI, RBO
  
- C-2 Brinker, Jason ESI  
Certification ID# 8936  
Current certifications- none
  
- C-3 Brown, Kenneth BI  
Certification ID# 8937  
Current certifications- none
  
- C-4 Collins, Thomas PI, PPE  
Certification ID# 8931  
Current certifications- none
  
- C-5 Hurt, Steven BI, RBI  
Certification ID# 8939  
Current certifications- none
  
- C-6 LaLonde, Douglas BPE  
Certification ID# 1992  
Current certifications- RPE, BI, RBO, MI, RMI, CBO
  
- C-7 Miller, Ronald - RBO  
Cert ID: 8934  
Current Certifications: None
  
- C-8 Newman, Michael - PI  
Cert ID:  
Current Certifications: None
  
- C-9 Spencer, Martin FPI  
Certification ID# 8940  
Current certifications- none, FSI since 1999.
  
- C-10 Stewart, Philip - BO, BPE, PPE, MechPE, EPE, FPPE  
Certification ID# 1429  
Current certifications- BI, MI, FPI, ESI, RBO
  
- C-11 Wagner, William - BO  
Certification ID# 5739  
Current certifications- BI, RBI, RBO

C-12 Wright, Charles - NRIUI  
Cert ID: 5488  
Current Certifications: RIUI

C-13 Capra, Roddy - RBO  
Cert ID:  
Current Certifications:

C-14 Wallace, Brandy - RIUI  
Cert ID:  
Current Certifications: None

**Consent-Certificates Issued Administratively**

A-1 Losekamp - RBI  
Sester - PI, PPE

**File Attachments for Item:**

P-1 Plaza-Serrano, Saul - BO

Cert ID: 1177

Current Certifications: BI, RBO

Staff Notes: Previously held BO interim, did not complete exams, denied in 2017 for recertification. Attending meeting to discuss testing history, plan for future exams.

Committee Recommendation:

Plaza Serrano  
Last Name

SAUL  
First Name

1177  
BBS Certification ID

**SECTION 1: CHECK INTERIM CERTIFICATION(S) BEING REQUESTED**

<input checked="" type="checkbox"/> Building Official	<input type="checkbox"/> Master Plans Examiner	<input type="checkbox"/> Building Inspector	<input type="checkbox"/> Electrical Safety Inspector	<input type="checkbox"/> Fire Protection Inspector
<input type="checkbox"/> Building Plans Examiner	<input type="checkbox"/> Plumbing Plans Examiner	<input type="checkbox"/> Mechanical Plans Examiner	<input type="checkbox"/> Electrical Plans Examiner	<input type="checkbox"/> Fire Protection Plans Examiner
	<input type="checkbox"/> Plumbing Inspector	<input type="checkbox"/> Mechanical Inspector	<input type="checkbox"/> Non-Residential Industrial Unit Inspector	

**SECTION 2: LIST ANY OHIO LICENSE, CERTIFICATE, OR REGISTRATION HELD**

(Mark "T" if Trainee)

Description		Certificate Number	Date Received
Architectural Registration			
P.E. Registration			
Res	Non-Res		
<input type="checkbox"/>	<input type="checkbox"/>	Building Official Certification	
<input type="checkbox"/>	<input type="checkbox"/>	Plans Examiner Certification	
<input type="checkbox"/>	<input checked="" type="checkbox"/>	Building Inspector Certification	1177 12-1998
<input type="checkbox"/>	<input type="checkbox"/>	Mechanical Inspector Certification	
Building Plans Examiner Certification			
Mechanical Plans Examiner Certification			
Fire Protection Plans Examiner Certification			
Electrical Plans Examiner Certification			
Plumbing Plans Examiner Certification			
Fire Protection Inspector Certification			
Electrical Safety Inspector Certification			
Plumbing Inspector Certification			
Fire Safety Inspector Certification			
Fire Protection System Designer Certification			
Medical Gas Piping Inspector Certification			

Plaza Serrano  
Last Name

SAUL  
First Name

1177  
BBS Certification ID

**SECTION 3: EMPLOYMENT/EDUCATION**

Formal Education	Date Graduated
Southview High Lorain Ohio 44055	1977
Related Vocational or Technical Training	Years' Experience
	N/A
U.S. Military construction experience (MOS or other designation):	Years' Experience
	N/A
Place of Employment: <u>City of Lorain</u>	Years' Employed
	26 years

**SECTION 4: APPLICANTS REQUESTING MEDICAL GAS INSPECTOR CERTIFICATION**

*Attach proof of certification by an ASSE recognized third-party certifier in accordance with ASSE standard 6020.*

**SECTION 5: OBC BUILDING INSPECTION EXPERIENCE PERFORMED FOR A BBS CERTIFIED BUILDING DEPARTMENT**

BBS Certified Building Department	BBS Certified Position/Title	Duties	Date of Service, Length of Time (MM/DD/YY)
City of Lorain	Building Inspector	INSPECTION OF 1, 2, 3 Family Dwelling & Commercial Inspection	10-1996 to Present
City of Lorain	Assistant Zoning Inspector	Approval of Zoning Application's Answering Zoning Related Questions meetings At Zoning Board inspection of Res, Comm.	2010 to 2021 Approx. 12 years



**Board of Building Standards**

Application for Interim Certification, Building Department Personnel

Plaza Serrano

SAUL

1177

Last Name

First Name

BBS Certification ID

List Each Construction Project <u>AND</u> Specific Type of Work Performed	Name of Employer, Contact, Address, Telephone Number	Project Time: From_ To _ (MM/YY)
INSPECTION OF 1, 2, 3 Family Dwellings & Commercial	City of Lorain 200 West ERIE AV. Lorain OHIO 44052	10-1996 To Present
<b>Total Experience on This Page (In Months):</b>		

Plaza Serrano

Last Name

Saul

First Name

1177

BBS Certification ID

SECTION 8: PERSONAL HISTORY

1. Have you ever been convicted of any felony, or any crime involving moral turpitude?

Yes No

If you answered "Yes" please explain below:

2. Have you served in the U.S. armed services? (If No, skip question 3)

Yes No

3. If YES, were you discharged under honorable conditions?

Yes No

If you answered "No" please explain below:

Empty table for explanation of "No" answers.

SECTION 9: CERTIFICATION

I certify the information contained in this application is true and complete, and I understand that providing false information may be grounds for not granting certification or for immediate termination of certification at any point in the future, if granted. I authorize the investigation of all statements contained herein and release all parties from all liability for any damage that may result from furnishing the same to Ohio Board of Building Standards. Falsification is a violation of section 2921.13 of the Ohio Revised Code and is punishable as a misdemeanor of the first degree.

Signature of Applicant: [Signature]

Subscribed and duly sworn before me according to law, by the above named applicant this day 10 of August in the year 2022 at Lorain, County of Lorain and State of Ohio.

Notary Public: [Signature]



DESIREE A. THOMPSON
Notary Public
In and for the State of Ohio
My Commission Expires
January 28, 2023

**File Attachments for Item:**

P-2 Seikel, Tim BI - Additional Information

Certification ID# 8893

Current certifications- none

Staff notes- All experience is as property insurance claims adjuster, with in person inspections of claims. Additional information requested at August 25 meeting: applicant will appear at meeting.

Committee recommendations-

Seikel  
Last Name

Tim  
First Name

\_\_\_\_\_  
BBS Certification ID

**SECTION 1: CHECK INTERIM CERTIFICATION(S) BEING REQUESTED**

<input type="checkbox"/> Building Official	<input type="checkbox"/> Master Plans Examiner	<input checked="" type="checkbox"/> Building Inspector	<input type="checkbox"/> Electrical Safety Inspector	<input type="checkbox"/> Fire Protection Inspector
<input type="checkbox"/> Building Plans Examiner	<input type="checkbox"/> Plumbing Plans Examiner	<input type="checkbox"/> Mechanical Plans Examiner	<input type="checkbox"/> Electrical Plans Examiner	<input type="checkbox"/> Fire Protection Plans Examiner
	<input type="checkbox"/> Plumbing Inspector	<input type="checkbox"/> Mechanical Inspector	<input type="checkbox"/> Non-Residential Industrial Unit Inspector	

**SECTION 2: LIST ANY OHIO LICENSE, CERTIFICATE, OR REGISTRATION HELD**

(Mark "T" If Trainee)

Description		Certificate Number	Date Received
Architectural Registration			
P.E. Registration			
Res	Non-Res		
<input type="checkbox"/>	<input type="checkbox"/>	Building Official Certification	
<input type="checkbox"/>	<input type="checkbox"/>	Plans Examiner Certification	
<input type="checkbox"/>	<input type="checkbox"/>	Building Inspector Certification	
<input type="checkbox"/>	<input type="checkbox"/>	Mechanical Inspector Certification	
Building Plans Examiner Certification			
Mechanical Plans Examiner Certification			
Fire Protection Plans Examiner Certification			
Electrical Plans Examiner Certification			
Plumbing Plans Examiner Certification			
Fire Protection Inspector Certification			
Electrical Safety Inspector Certification			
Plumbing Inspector Certification			
Fire Safety Inspector Certification			
Fire Protection System Designer Certification			

Seikel  
Last Name

Tim  
First Name

\_\_\_\_\_  
BBS Certification ID

**SECTION 3: EMPLOYMENT/EDUCATION**

*(Insurance Adjuster)*

Formal Education	Date Graduated
<i>Ohio Dominican College - Business Admin</i>	<i>1985</i>
Related Vocational or Technical Training - <i>Structural Training</i>	Years' Experience
<i>Residential Building Estimating</i>	<i>30 years 1987-2022</i>
<i>Commercial Building Estimating</i>	<i>15 + years 2006-2022</i>
U.S. Military construction experience (MOS or other designation):	Years' Experience
Place of Employment:	Years' Employed
<i>Sedgwick - Insurance Adjuster</i>	<i>(16 years) 2006-2022</i>
<i>Insurance Adjuster - Foremost Ins.</i>	<i>(10 years) -1987-1997</i>

**SECTION 4: APPLICANTS REQUESTING MEDICAL GAS INSPECTOR CERTIFICATION**

**Attach proof** of certification by an ASSE recognized third-party certifier in accordance with ASSE standard 6020.

**SECTION 5: OBC BUILDING INSPECTION EXPERIENCE PERFORMED FOR A BBS CERTIFIED BUILDING DEPARTMENT**

BBS Certified Building Department	BBS Certified Position/Title	Duties	Date of Service, Length of Time (MM/DD/YY)

Seikel  
Last Name

Tim  
First Name

\_\_\_\_\_  
BBS Certification ID

**SECTION 6: ELECTRICAL SAFETY INSPECTOR (ESI) - SPECIFIC EXPERIENCE QUALIFICATIONS**

Applicants for Electrical Safety Inspector Only Must Complete This Item

Section 3783 of the Ohio Revised Code specifies that an applicant for a Certificate of Competency as an Electrical Safety Inspector must meet one of the following to qualify to take required examination. Please check the qualification that applies:

1.  Have been a journeyman electrician or equivalent for four years, two of which were as an electrician foreman, and have had two years' experience as a building department electrical inspector trainee;
2.  Have been a journeyman electrician or equivalent for four years and have had three years' experience as a building department electrical inspector trainee;
3.  Have had for four years' experience as a building department electrical inspector trainee;
4.  Have been a journeyman electrician or equivalent for six years;
5.  Am a graduate electrical engineer and registered in the State of Ohio. Registration number: \_\_\_\_\_
6.  Applicant authorizes all testing organizations including ICC to provide test results to the BBS.

**SECTION 7: EXPERIENCE (DO NOT SUBSTITUTE WITH OTHER RESUMES).**

Refer to Experience Requirements Listed in O.A.C. 4101:7-3-01 and O.R.C. 3783

Below, list the specific projects you worked on, and the specific work you performed, your typical duties for each project, and dates of this work. You **must** demonstrate that you have the required number of months (years) of actual, practical experience for the certification requested (see matrix).

Provide letters from certified inspectors, employers, or contractors verifying your experience. Submit copies of any certificates, diplomas, or licenses. Remove all personal information.

**SECTION 7 CONT.: EXPERIENCE**

List Each Construction Project <u>AND</u> Specific Type of Work Performed	Name of Employer, Contact, Address, Telephone Number	Project Time: From_ To _ (MM/YY)
<p><i>Example:</i> Children's Hospital, Toledo Structural steel work on addition</p>	<p>Homer Steel and Trade 125 Anytown Street My City, OH, 45454 (419)555-1212</p>	<p>July 2013-May 2014 (10 months)</p>
<p>① Inspected over 3000 Residential + Commercial Per claim: Buildings</p> <p>② Property Damage Building inspections To Determine Estimate of Damage for Repairing Property within Building Codes.</p>	<p>Sedgwick 8125 Sedgwick Way Memphis TN 38125 (Currently Employed-Please do NOT Contact)</p>	<p>February 2006 to Current 2022 (186 months of Building inspections)</p>
<p>Total Experience on This Page (In Months): <u>186</u></p>		

Seikel  
Last Name

Tim  
First Name

\_\_\_\_\_  
BBS Certification ID

List Each Construction Project <u>AND</u> Specific Type of Work Performed	Name of Employer, Contact, Address, Telephone Number	Project Time: From _ To _ (MM/YY)
Property Damage Building inspector Estimating Building Damage	ASU Group P.O. Box 77 2120 University Park Dr. Okemos MI 48805 (517)-349-2212	March 2005 to February 2006 (11 months)
Insurance Adjuster 30+ years ① Knowledge of floor and wall installation ② Knowledge of Roofing installation ③ Knowledge of Plumbing installations - Estimating Building Repairs to Conform to Building Codes	Foremost Insurance 5600 Beechtree Lane Caledonia MI 49316 (800)527-3905	January 1988 to June 1997 110+
Total Experience on This Page (In Months):		121

E) Experience requirements of Applicant to Qualify for Certification;  
 (Page 4) (e) Knowledge of different construction methods, as I have  
 knowledge of Roof, floor and wall construction.  
 (30+ years)

Seikel  
Last Name

Tim  
First Name

\_\_\_\_\_  
BBS Certification ID

**SECTION 8: PERSONAL HISTORY**

1. Have you ever been convicted of any felony, or any crime involving moral turpitude?  
 Yes  No

If you answered "Yes" please explain below:

2. Have you served in the U.S. armed services? (If No, skip question 3)  Yes  No

3. If YES, were you discharged under honorable conditions?  Yes  No

If you answered "No" please explain below:

**SECTION 9: CERTIFICATION**

I certify the information contained in this application is true and complete, and I understand that providing false information may be grounds for not granting certification or for immediate termination of certification at any point in the future, if granted. I authorize the investigation of all statements contained herein and release all parties from all liability for any damage that may result from furnishing the same to Ohio Board of Building Standards. Falsification is a violation of section 2921.13 of the Ohio Revised Code and is punishable as a misdemeanor of the first degree.

Signature of Applicant: [Signature]

Subscribed and duly sworn before me according to law, by the above named applicant this day 28<sup>th</sup> of July in the year 2022 at Soupath OH, County of Summit and State of Ohio.

Notary Public: Amber Keaton





- (39) Residential mechanical inspector trainee.
- (40) Electrical safety inspector.
- (41) Electrical safety inspector trainee.
- (42) Industrialized unit inspector.
- (43) Interim industrialized unit inspector.
- (44) Residential industrialized unit inspector.
- (45) Interim residential industrialized unit inspector.
- (46) Plumbing inspector.
- (47) Interim plumbing inspector.
- (48) Plumbing inspector trainee.
- (49) Medical gas piping inspector.

**(B) Multiple personnel certifications held.** A person may hold more than one certification.

**(C) Conflict of interest.** No certified employee or person who contracts for services within the jurisdictional area of a residential or non-residential building department shall perform services for any department which would require that person or employee to exercise authority or make an evaluation of any work furnished by him or by a private contractor that employs him on a full-time, part-time, or incidental basis. Further, such employee or person shall not engage in conduct that is prohibited or considered a conflict of interest pursuant to Chapter 102. of the Revised Code.

**(D) Seals.** No holder of a certification issued by the board of building standards is authorized to secure a seal in any form or of any type for use in the performance of any of their duties.

**(E) Experience requirements of the applicant to qualify for certification.**

**(1) General experience.** To qualify for certification, applicants must have experience directly related to buildings or structures within the scope of the "Residential Code of Ohio" for residential certifications or experience directly related to buildings or structures within the scope of the "Ohio Building Code" for nonresidential certifications.

**(a)** In evaluating experience of an applicant, the board of building standards may find the following enforcement, inspection, or plans examination experience to be acceptable:

- (i) Experience gained prior to 1984, with a non-residential building department certified by the board of building standards to exercise enforcement authority for buildings or structures within the scope of groups regulated by the rules of the board; or
- (ii) Experience gained with the department of commerce, division of industrial compliance or an agency or jurisdiction outside the state of Ohio enforcing a model residential code, for residential certifications, or a model non-residential building code, for nonresidential certifications, of a national model code organization or a code adopted for the respective buildings or structures of the types regulated by the rules of the board; or
- (iii) Certification by the department of commerce, division of industrial compliance, as a plumbing inspector when application is made for board certification as a plumbing inspector; or
- (iv) Experience gained as an employee of a certified residential or nonresidential building department and who is a holder of a board certification other than that for which application is being made as prescribed in this rule.

**Exceptions:**

- (a) Certified building department employees who are applicants for plumbing inspector certification shall comply with paragraph (E)(16) of this rule.
  - (b) Certified building department employees who are applicants for electrical safety inspector certification shall comply with paragraph (E)(17) of this rule.
  - (b) The board of building standards shall not credit experience gained while acting in violation of rules adopted by the board to establish equivalent experience.
  - (c) The board of building standards may credit experience which provides knowledge of different construction methods, processes, or types as it determines applicable, but shall not credit construction experience that does not provide required knowledge including, but not limited to, the installation of floor and wall coverings, the installation of roofing materials or roofing systems, or the finishing of concrete.
  - (d) For a residential or nonresidential certification, the board of building standards shall credit one year of the required experience obtained through education credit pursuant to paragraph (F)(6) of this rule.
  - (e) Individuals certified as non-residential building officials, master plans examiners, or building inspectors must make application to the board but individuals will qualify without further testing and without providing related experience to become a residential building official, residential plans examiner, and/or residential building inspector.
- (2) **Building official.** An applicant for a building official certification shall meet one of the following requirements:
- (a) At least five years of experience in non-residential building design and construction for buildings or structures within the scope of groups regulated by the rules of the board while registered in Ohio as an architect or professional engineer;
  - (b) At least ten years of experience as a general contractor or superintendent of building construction for buildings or structures dealing with all phases and trades of construction including the responsibility for obtaining approvals and inspections within the scope of groups regulated by the rules of the board; or
  - (c) At least five years of experience employed full-time as a residential building official in a certified residential building department.

In evaluating the experience requirements for this certification, the board may accept applicable experience as specified in paragraph (E)(1) of this rule.

- (3) **Residential building official.** An applicant for a residential building official certification for a residential building department shall meet one of the following requirements:
- (a) Ohio registration as an architect or professional engineer; or
  - (b) At least five years of experience as a residential contractor or non-residential contractor or superintendent with responsibility for obtaining approvals and inspections of structures regulated by the rules of the board.

In evaluating the experience requirements for this certification, the board may accept applicable experience as specified in paragraph (E)(1) of this rule.

TIM G. SEIKEL



**WORK EXPERIENCE**

<b>Dates Employed</b>	<b>Job Title</b>	<b>Company</b>
<u>February 2006 to Present</u>	<u>SR. Claims Adjuster</u>	<u>Sedgwick</u>

Working from my home office, handling large and small property and casualty claims. Investigating and evaluating damages and handling claims process from beginning to resolution for clients. Attended numerous mediations and settlement conferences for clients and worked with defense attorneys to reach settlement of lawsuits with claimants and plaintiffs attorneys.

Currently licensed as an insurance adjuster in numerous states.

<u>3/2005 – 2/2006</u>	<u>SR. Claims Adjuster</u>	<u>ASU GROUP</u>
------------------------	----------------------------	------------------

Handling property and casualty claims as assigned. Investigating and determining coverage for a multitude of losses. Estimating property damage and settling bodily claims.

<u>5/2003 - 3/2005</u>	<u>SR. GENERAL LIABILITY ADJUSTER</u>	<u>AJ GALLAGHER</u>
------------------------	---------------------------------------	---------------------

Handling General liability investigations for retail Properties. Investigating and analyzing state laws and negligence to determine liability on the part of the Property.

<u>2/2002 - 3/2003</u>	<u>BRANCH MANAGER</u>	<u>NATIONAL CITY BANK</u>
------------------------	-----------------------	---------------------------

Manager of grocery store branch. Sales responsibilities included generation of new accounts and loans. Responsible for loan closing, annuity sales, and training of branch personnel.

<u>12/2000 - 12/2001</u>	<u>RETAIL INSURANCE SPECIALIST</u>	<u>HUNTINGTON BANK</u>
--------------------------	------------------------------------	------------------------

Responsible for marketing insurance products through retail branch locations. Working with and assisting licensed personal bankers in the sale of insurance products.

Responsible for insurance production at 22 branch locations.

12/1999 - 9/2000 AMERICAN FAMILY AGENT SEIKEL INS. AGENCY

Selling Auto, Home, Life and financial services as an American Family Captive agent.

1/1988 - 6/1997 SR. FIELD CLAIMS REPRESENTATIVE FOREMOST

DALLAS/TEXAS: Field Claims Adjuster, investigating claims for company and handling from initial claim report to resolution. Investigating and resolving both property and casualty claims.

**SKILLS**

Excellent Computer skills. Software estimating experience with Xactimate, Boech and Simsol. Previously using Lotus Notes and currently using Outlook for email.

Extensive construction knowledge due to inspecting over 10,000 Residential and commercial buildings in my career estimating damage to structures.

**INSURANCE LICENSES (Held or previously held)**

Mississippi, Connecticut, New Hampshire, Florida, Kentucky, South Carolina, Maine, Oklahoma, and Texas (since 1989).

Licensed Agent in Ohio for Property & Casualty, and Life.

**EDUCATION**

1981 - 1985 Ohio Dominican College COLUMBUS, OHIO

Bachelor' of Arts Business Administration

**INSURANCE INSTITUTE OF AMERICA**

**AIC**--Associate in Claims, completed 2008

**AIS**--Associate in Insurance Services, completed 2006

**INS**--General Insurance, completed 2005

Extensive Structural training over 30 years in the business of insurance adjusting.

Professional references can be provided upon request.

Hello Building Standards Board,

**Additional Structural Education and Experience.**

For my first position in 1988, I completed building construction training at the corporate training location for Foremost insurance that included all the components of building construction from the roof to the foundation and all the finish carpentry and mechanicals.

I worked for Foremost and estimated damage to structures at over 300 structures per year, around 3000 properties in 10 years inspected.

I then completed the Allstate Structural training in Dallas TX in 1999 before I moved back to Ohio. I then worked for numerous independent adjusting companies over the past 20 years and have inspected over 250 structures a year for the past 20 years of which about 10 % were commercial buildings. Over 5000 structures inspected in that time estimating building damage.

Code upgrade coverage applies to most insurance policies and the most common I have run across is Ice and water shield requirements for roof replacements.

Since I am familiar with the installation of framing, floor, wall and different roofing materials and systems, makes me feel like it would be a perfect candidate for a building inspector position.

I included my initial training manual and included it with this note for your information. Thanks for you consideration.

Tim G. Seikel

Building Inspector Applicant

██████████

# **Property Damage Appraisal Manual**

*for*

# **HOMES**

**Site-Built • Mobile Homes  
Modular Homes**



# CARPENTRY

Times used specifically in mobile home repairs have been listed under **Mobile Home** subtitle. Times listed under **Site Built** are applicable to both mobile home and site built construction.

ROUGH FRAMING	GENERAL		LOCAL	
	Unit/Material	Labor Allowance (in hours)	Material	Unit Cost
<b>Mobile Home</b> <i>Removal Included</i>				
Floor Joists and Sill	Ea.	0.5		
Studding (2x4)	Ea.	0.3		
Plates	Ea.	0.4		
Rafters/Trusses	Ea.	0.5		
<b>Site Built</b> <i>Removal Not Included</i>				
Sills and Plates	100 FBM	2.0		
Studding	100 FBM	2.2		
Joists (2x6)	100 FBM	2.0		
Rafters	100 FBM	3.0		
Trusses	100 FBM	6.0		
Bridging	50 Sets (2)	4.0		
Other framing	100 FBM	2.5		

SHEATHING AND SUBFLOOR	GENERAL		LOCAL	
	Unit/Material	Labor Allowance (in hours)	Material	Unit Cost
<b>Mobile Home</b>				
Subfloor Re-section (Includes removal and scabbing) Add ½ hr. per job set-up when necessary Minimum subfloor repair	32 Sq. Ft.	2.0		
	Less than 16 Sq. Ft.	1.0		
<b>Site Built</b>				
Ext. Sheathing (1" x 6" or 8" boards)	100 FBM	1.4		
Ext. Sheathing-plywood	100 Sq. Ft.	1.1		
Ext. Sheathing removal	100 Sq. Ft.	1.5		
Subfloor plywood/Particle Board	100 Sq. Ft.	1.0		
Subfloor-diagonal boards	100 FBM	1.5		
Subfloor removal	100 Sq. Ft.	3.5		
Roof deck plywood	100 Sq. Ft.	1.2		
Roof deck (1" x 6" or 8" board)	100 FBM	1.6		
Roof decking removal	100 Sq. Ft.	2.0		
Add appropriate material waste <b>before</b> computing labor.				

## NOTES

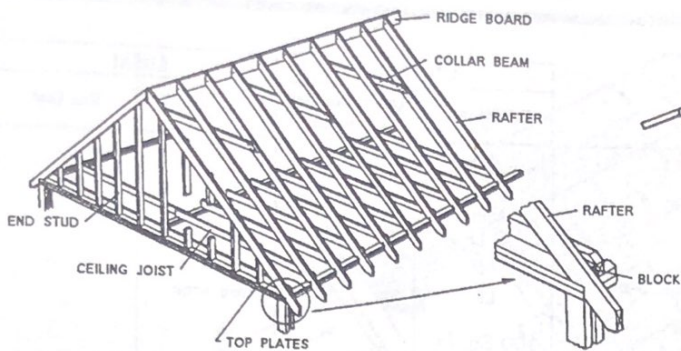

Ceiling and roof framing - overall view of gable roof framing.

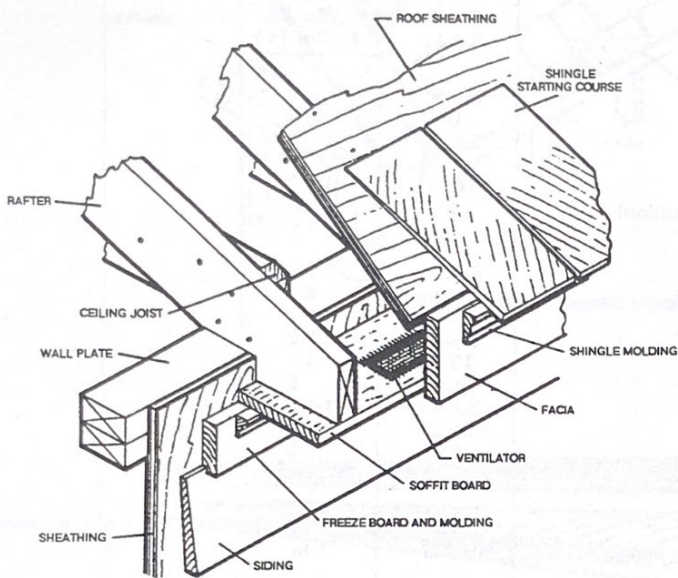
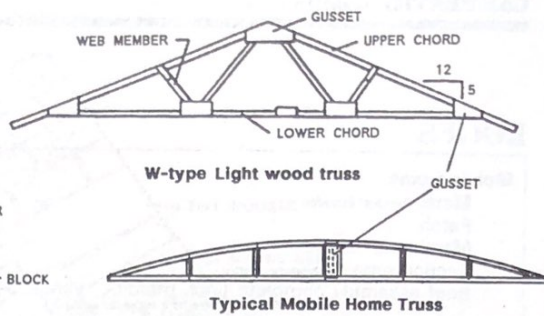

Narrow Box Cornice.

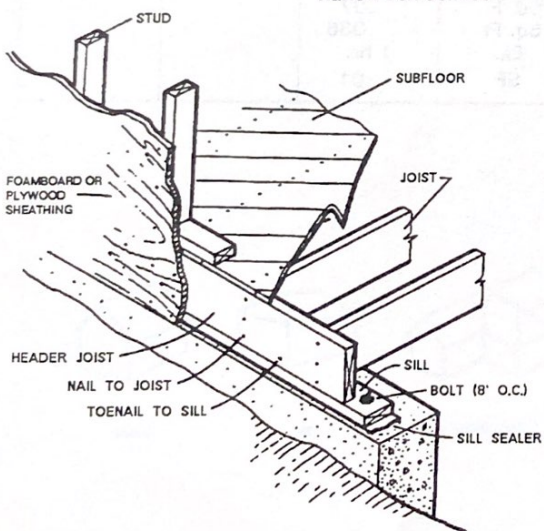
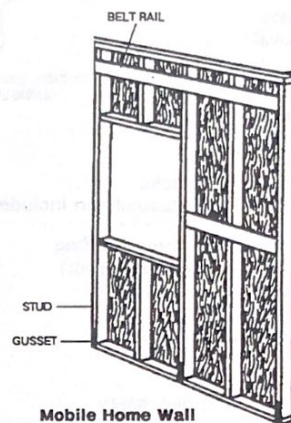

Platform Construction

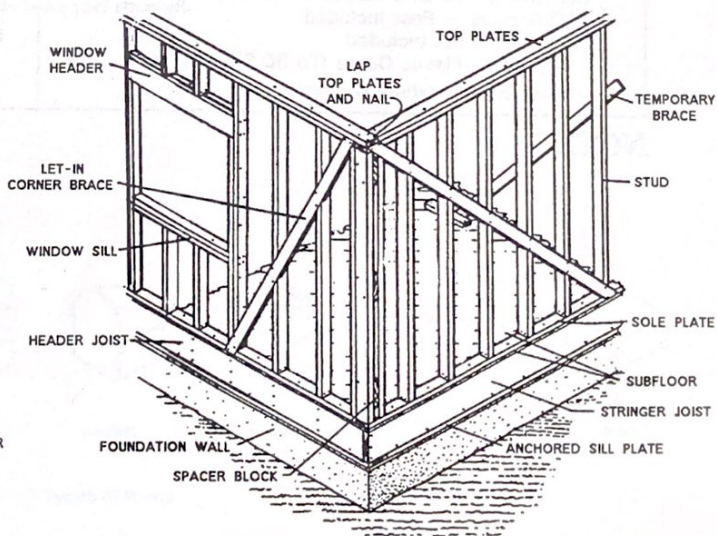

Wall framing used with platform construction.



ROOFS	GENERAL		LOCAL	
	Unit/Material	Labor Allowance (in hours)	Material	Unit Cost
<b>Mobile Home</b>				
<b>Metal</b> <i>Removal Included</i>				
Patch	Min.	.5		
Membrane seams	3 LF	.1		
Section repair <i>(Compute length)</i>	LF	.5		
Roof assembly complete (incl. molding, vents, J-rail) <i>(Double the time if roof off both halves of a modular unit.)</i>	LF	.5		
Roof coating <i>Approximate coverage is 100 Sq. Ft. per gallon.</i>				
Seams	100 Sq. Ft.	.2		
Entire surface	100 Sq. Ft.	.3		
Clean roof surface — when necessary	100 Sq. Ft.	.1		
<b>Foam Roof Cover</b>				
<i>Labor allowance figures not available. Unit cost prices are indicated.</i>				
Patch	Sq. Ft.			Unit Cost
Replace	Sq. Ft.			(\$1/Sq. Ft.)
Removal	Sq. Ft.			(\$2/Sq. Ft.)
<b>Rubber Roof Cover</b>				
Patch	Sq. Ft.	.5		
Replace	LF	.5		
Removal	Sq. Ft.	.01		
<b>Other</b>				
Vents, jacks, stacks	Ea.	.3		
J-Rail or Gutter (usually an included operation)	20 LF	1.0		
<b>Shingles and Other Type Roofing</b>				
*Self-sealing shingles (reroof)	Square	2		
Hexagonal shingles	Square	6		
Wood shake	Square	3		
Roll roofing (over old)	Square	1.5		
Flashing	15 LF	1		
Felt	Square	.5		
Removal — if necessary	Square	1-1 1/2		
Gutters	20 LF	1.0		
Vents	Ea.	1.0		
<i>* Hourly allowance should be increased when roof design is other than plain. Add 10 percent for steep slopes.</i>				
<b>Miscellaneous</b>				
*Prefabricated Aluminum Carport/Patio Awnings — Post Included (Plus 3 hr. set-up)	10 LF	1 hr.		
Constructed On Site Carport/Patio Awnings				
*Fiberglass — Post Included	Sq. Ft.	.07		
*Other — Post Included	Sq. Ft.	.036		
Skylights—Plastic Dome (To 30 Sq. Ft.)	Ea.	1 hr.		
*Add removal where necessary	SF	.01		

NOTES

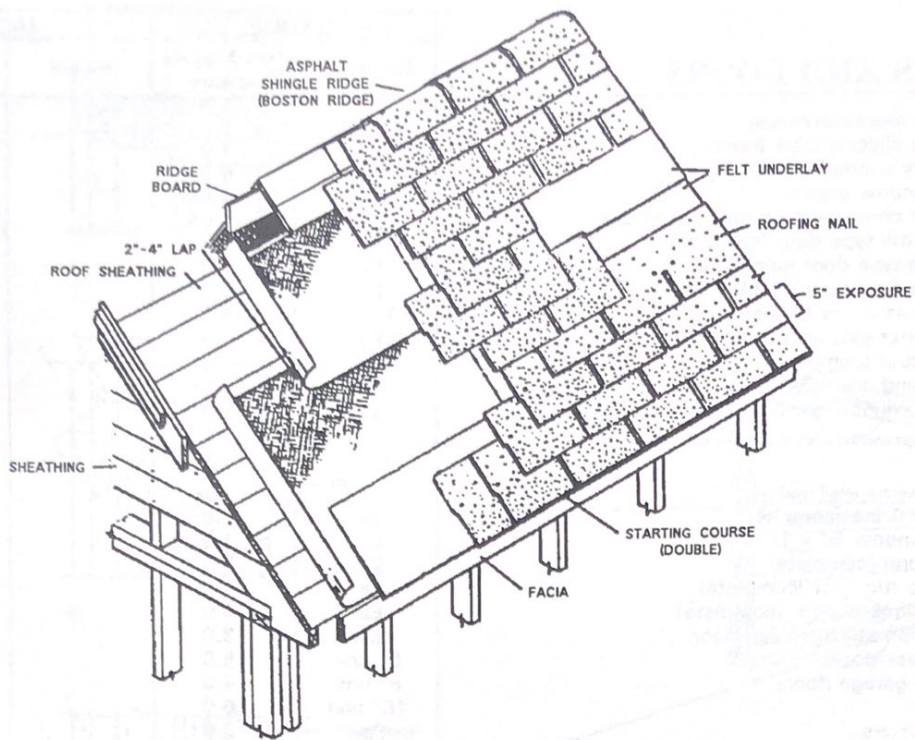

Application of asphalt shingles.

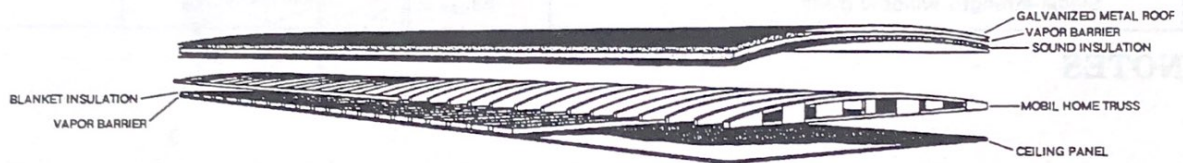

Mobile home roof structure.

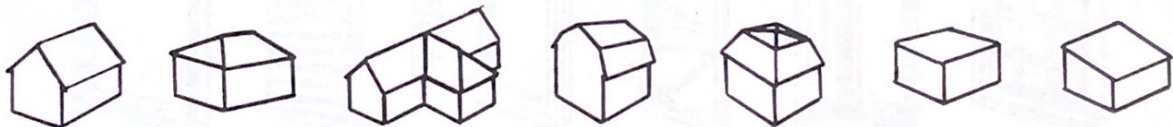

GABLE      HIP      INTERSECTING      GAMBREL      MANSARD      FLAT      SHED

Types of Roofs

**WINDOWS AND DOORS**

	GENERAL		LOCAL	
	Unit/Material	Labor Allowance (in hours)	Material	Unit Cost
<b>Mobile Home</b> <i>(Times Include Removal)</i>				
Aluminum slider double frame	Ea.	1.0		
Bay or bay window	Ea.	4.0		
Plastic window inserts	- Ea.	.05		
Aluminum combination storm/screen door	Ea.	1.0		
Mobile home type door (complete)	Ea.	1.5		
*MH house-type door (complete)	Ea.	3.0		
MH house-type door (blank)	Ea.	1.5		
Sliding glass doors (complete)	6' unit	5.0		
Water heater ext. access door	Ea.	.5		
Int. H/C door (complete)	Ea.	.5		
Shutters and columnades	Ea.	.2		
Door and window awnings	LF	1.0		
* Add 1 hour for rough opening alterations if necessary				
<b>Site Built</b> <i>(Add removal when necessary)</i>				
Casement 1 lite (complete)	Ea.	1.5		
Picture window 5' x 10'	Ea.	4.0		
Double hung (complete)	Ea.	2.0		
Int. prefab h/c door (complete)	Ea.	2.0		
Ext. wood/metal door (complete)	Ea.	4.0		
Combination storm/screen door	Ea.	3.0		
Sliding glass doors	6' unit	5.0		
Overhead garage doors	8' unit	4.0		
	16' unit	6.0		
Wood shutters	Pair	2.0		
<b>Glass/Glazing</b> <i>(Add for knock-out of damaged glass)</i>				
Install in wood/metal sash (with glazing)				
Single-strength window glass	Sq. Ft.	.10		
Tempered or plate	Sq. Ft.	.15		
Install in metal sash (no glazing)				
Single-strength window glass	Ea.	.5		

**NOTES**



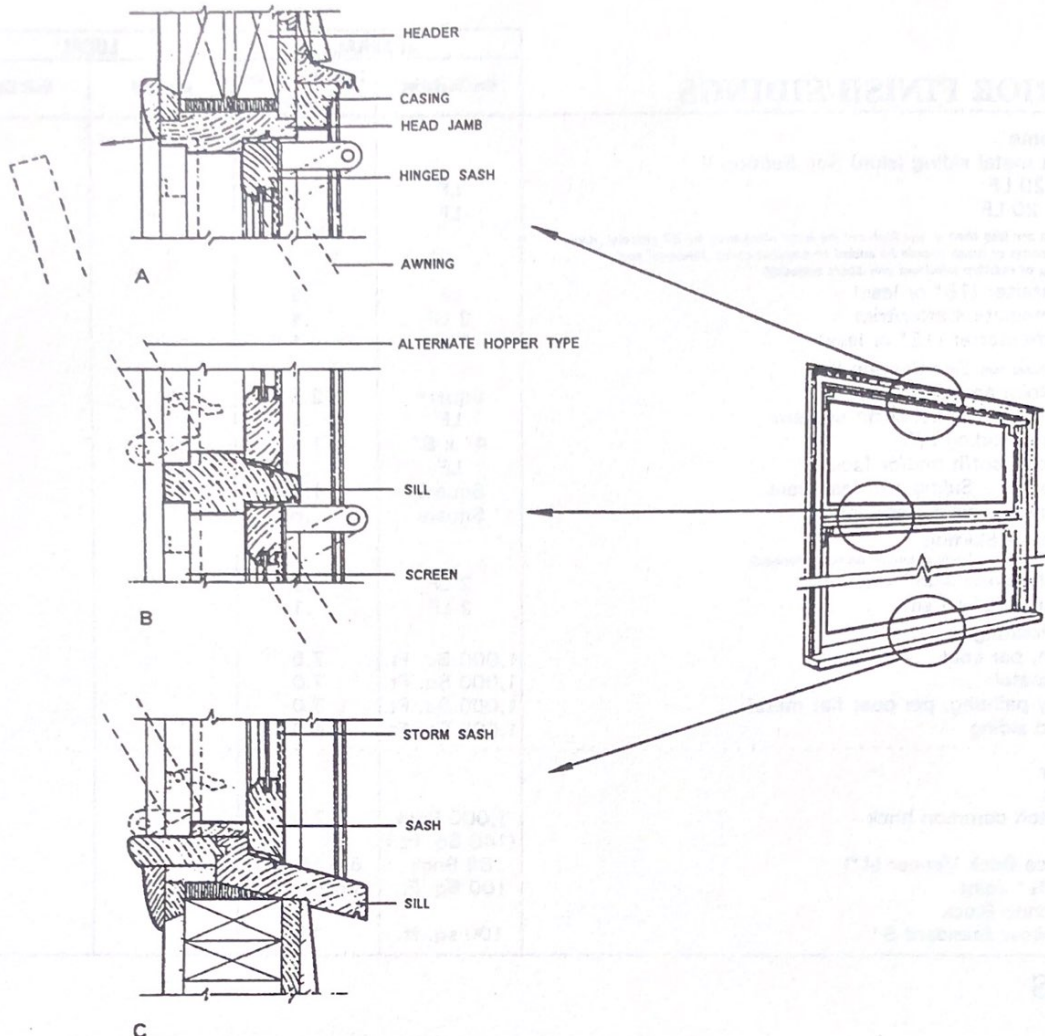

**Awning window. Cross sections: A, Head jamb; B, horizontal mullion; C, sill**

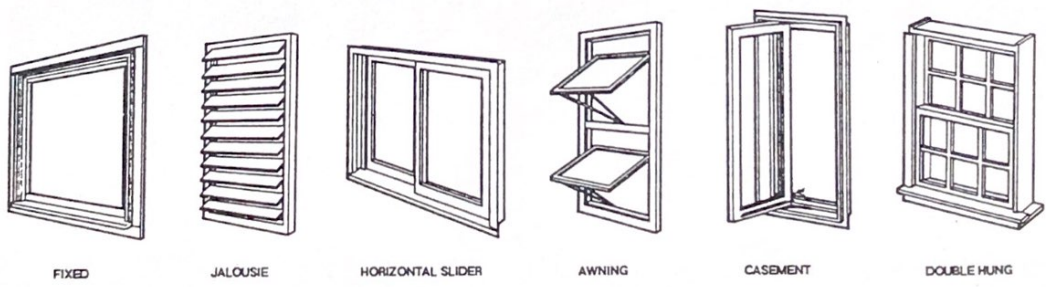

**FIXED      JALOUSIE      HORIZONTAL SLIDER      AWNING      CASEMENT      DOUBLE HUNG**

**Types of Windows**

**EXTERIOR FINISH/SIDINGS**

	GENERAL		LOCAL	
	Unit/Material	Labor Allowance (in hours)	Material	Unit Cost
<b>Mobile Home</b>				
Sheet metal siding (skin) See Section II				
First 20 LF	LF	.5		
After 20 LF	LF	.3		
<i>If sheets are less than 4 feet high reduce labor allowance by 50 percent. Any special crimp or break should be added to material costs. Removal and resetting of existing windows and doors included.</i>				
Top starter (18" or less)	LF	.1		
Intermediate starter/trim	2 LF	.1		
Bottom starter (12" or less)	2 LF	.1		
<b>Siding (Includes trim) See Section II</b>				
Aluminum and Vinyl Lap	Square	2.5		
Aluminum or vinyl soffit system	LF	.5		
Plywood siding 5/8"	4' x 8'	1.0		
Plywood soffit and/or fascia	LF	.12		
Removal - Siding and fasteners	Square	1.25		
Removal - Fasteners only	Square	.5		
<b>Mobile Home Skirting</b>				
<i>(Add 0.5 hr. for set-up if only operation being performed)</i>				
Prefabricated aluminum/vinyl	2 LF	.1		
Constructed on site	2 LF	.1		
<b>Exterior Painting</b>				
Brush, per coat	1,000 Sq. Ft.	7.5		
Flat metal	1,000 Sq. Ft.	7.0		
Spray painting, per coat flat metal	1,000 Sq. Ft.	5.0		
Wood siding	1,000 Sq. Ft.	4.0		
<b>Masonry</b>				
Brick				
Patch common brick	1,000 Brick (140 Sq. Ft.)	7.0		
Face Brick Veneer (4")	88 Brick	6.5 Mason		
1/2" Joint	100 Sq. Ft.	5.0 Laborer		
Concrete Block				
Hollow Standard 8"	100 sq. ft.	13		

**NOTES**

**INSULATION AND WEATHERPROOFING**

	GENERAL		LOCAL	
	Unit/Material	Labor Allowance (in hours)	Material	Unit Cost
<b>Mobile Home</b>				
Bottom Fiber Paper (Black Paper, Shepards Board, Flex-mend)	Min.	.5		
Insulation Board (Homosote)	100 Sq. Ft.	1.0		
	Min.	.5		
	100 Sq. Ft.	1.5		
.....				
<b>Site Built</b>				
<b>Fiberglass</b>				
6" paper backed	100 Sq. Ft.	1.0		
3" paper backed	100 Sq. Ft.	1.0		
6" plain back batt	100 Sq. Ft.	1.5		
6" loose/poured	100 Sq. Ft.	1.0		
Cellulose <i>Add blowing machine cost when necessary</i>	100 Sq. Ft.	.2		
Polystyrene board 1"	100 Sq. Ft.	1.5		
Plastic vapor barrier .004 mill	100 Sq. Ft.	.33		
Caulking	100 LF	1.5		

**NOTES**

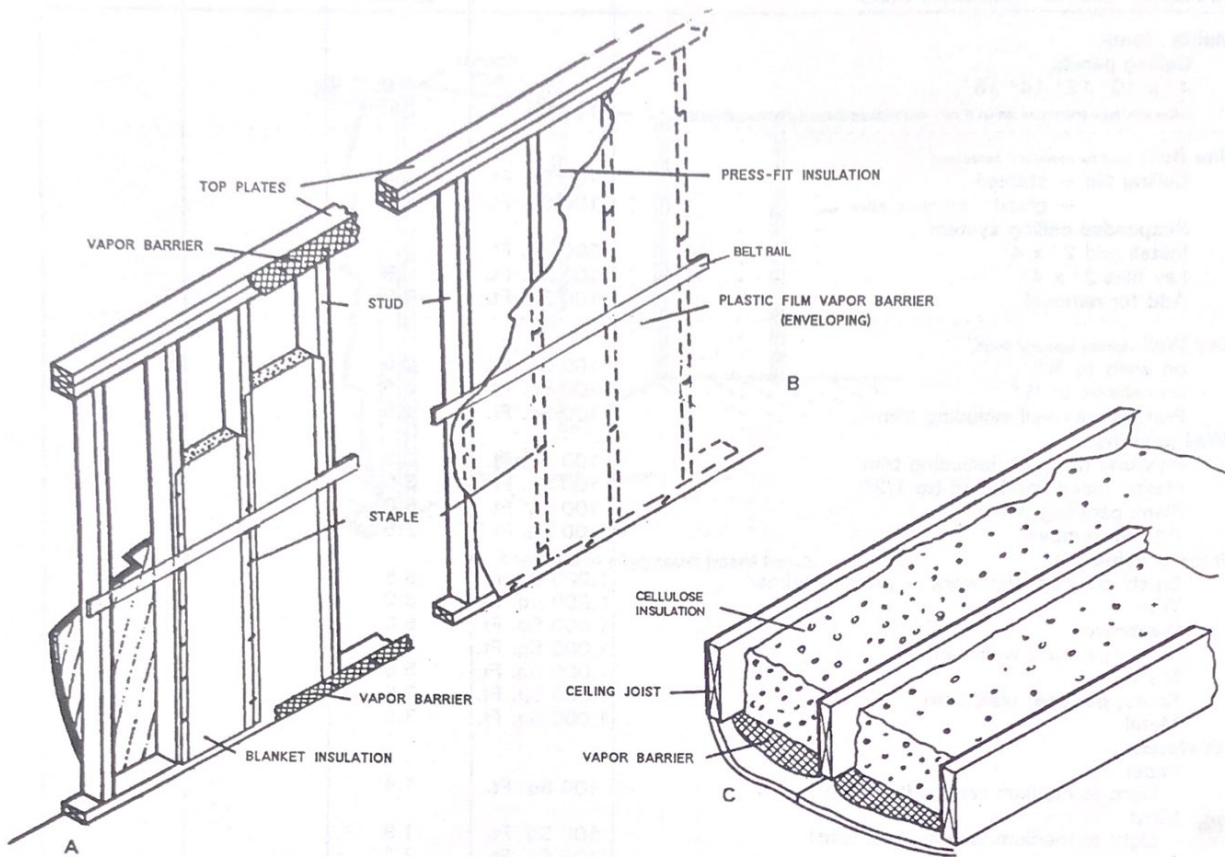

Application of insulation: A, Wall section with blanket type;  
 B, wall section with "press-fit" insulation; C, ceiling with full insulation.

# FINISH/ DECORATING

Times used specifically in mobile home repairs have been listed under **Mobile Home** subtitle. Times listed under **Site Built** are applicable to both mobile home and site built construction.

WALLS AND CEILINGS	GENERAL		LOCAL	
	Unit/Material	Labor Allowance (in hours)	Material	Unit Cost
<b>Mobile Home</b>				
Ceiling panels 4' x 10' 12' 14' 16'	Min.	2.0		
<i>Allow one hour (minimum) set-up if only operation performed. Removal Included.</i>	100 Sq. Ft.	3.0		
<b>Site Built</b> <i>(Add for removal if necessary)</i>				
Ceiling tile — stapled	100 Sq. Ft.	4.0		
— glued	100 Sq. Ft.	2.0		
<b>Suspended ceiling system</b>				
Install grid 2' x 4'	100 Sq. Ft.	2.1		
Lay tiles 2' x 4'	100 Sq. Ft.	.8		
Add for removal	100 Sq. Ft.	1.0		
<b>Dry Wall</b> <i>Includes tape and finish.</i>				
on walls to 1/2"	100 Sq. Ft.	2.0		
on ceilings to 1/2"	100 Sq. Ft.	2.5		
Prefinish drywall including trim	100 Sq. Ft.	1.5		
<b>Wall paneling</b>				
Plywood (to 1/2") including trim	100 Sq. Ft.	3.5		
Plastic faced hardboard (to 1/2")	100 Sq. Ft.	3.0		
Plank paneling 3/4"	100 Sq. Ft.	5.0		
Add for removal	100 Sq. Ft.	1.5		
<b>Interior Painting</b>				
Brush, per coat flat work — paint or primer	1,000 Sq. Ft.	8.5		
Trim	1,000 Sq. Ft.	8.0		
Wallboard	1,000 Sq. Ft.	5.5		
Roller, per coat wallboard	1,000 Sq. Ft.	3.0		
Metal	1,000 Sq. Ft.	5.5		
Spray, per coat wallboard	1,000 Sq. Ft.	2.5		
Metal	1,000 Sq. Ft.	3.5		
<b>Wallpaper</b>				
Paper				
Light to medium weight (butt joint)	100 Sq. Ft.	1.4		
Vinyl				
Light to medium weight (butt joint)	100 Sq. Ft.	1.9		
Heavy	100 Sq. Ft.	2.1		
Removal	150 Sq. Ft.	1.0		
<b>Plaster (wet)</b>				
Gypsum Lath 3/8"	100 Sq. Ft.	1.0		
2 Coats with finish — Wall	100 Sq. Ft.	42.0		
2 Coats with finish — Ceiling	100 Sq. Ft.	46.5		
<b>Stucco</b>				
Vapor barrier, wire, netting	100 Sq. Ft.	5.0		
<b>Ceramic Tile</b> <i>Set in adhesive — Includes grout.</i>				
Wall 2" x 2"	Sq. Ft.	.1		
Wall 4 1/2" x 4 1/2"	Sq. Ft.	.11		
Floors	Sq. Ft.	.15		
Cap and base	LF	.2		
Removal — All	Sq. Ft.	.035		

## NOTES



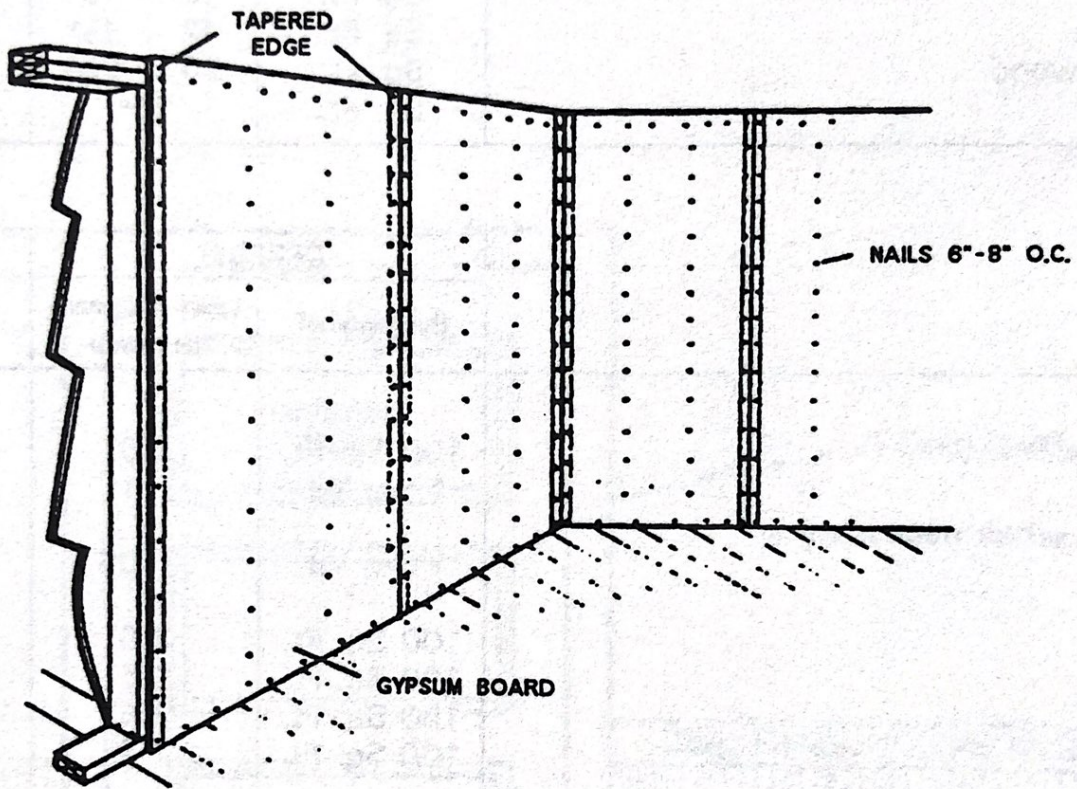

**Application of gypsum board finish.**

FINISH/MILL CARPENTRY	GENERAL		LOCAL	
	Unit/Material	Labor Allowance (in hours)	Material	Unit Cost
<b>Exterior Trim</b>				
Corner Boards	100 LF	4.0		
Cornice	100 LF	12.0		
<b>Baseboard</b>				
Simple	100 LF	2.0		
Difficult (3 member)	100 LF	5.0		
<b>Chair Rail</b>				
Simple	100 LF	2.0		
Difficult	100 LF	3.0		
<b>Interior Cornice/Crown</b>				
Simple	100 LF	10.0		
Difficult	100 LF	18.0		
<b>Battens</b>				
Simple	10 LF	.1		

CABINETS <small>(Material costs may vary greatly depending on the quality of workmanship.)</small>	GENERAL		LOCAL	
	Unit/Material	Labor Allowance (in hours)	Material	Unit Cost
<b>Mobile Home</b>				
Base or Wall Cabinets	LF	.2		
<b>Site Built Cabinets</b>				
Base 9" - 18"	Ea.	1.0		
Base 21" - 36"	Ea.	1.2		
Corner Base	Ea.	2.0		
Wall 9" - 18"	Ea.	1.0		
Wall 20" - 36"	Ea.	1.3		
Corner Wall	Ea.	1.5		
<b>Counter Top</b>				
Factory Formed Plastic With Backsplash	LF	.3		
Ceramic Tile	Sq. Ft.	.15		
Corian with Sink 25" - 36"	Ea.	1.0		
<b>Miscellaneous</b>				
Medicine Cabinet	Ea.	1.0		
Vanity - Plain	Ea.	1.5		
Vanity with water line and faucets	Ea.	3.0		
Removal - All	LF	.2		

NOTES

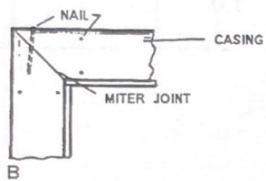
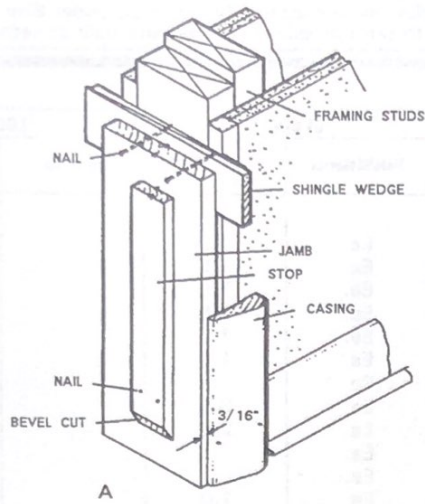

**Doorframe and trim:**  
A, Installation; B, miter joint for casing.

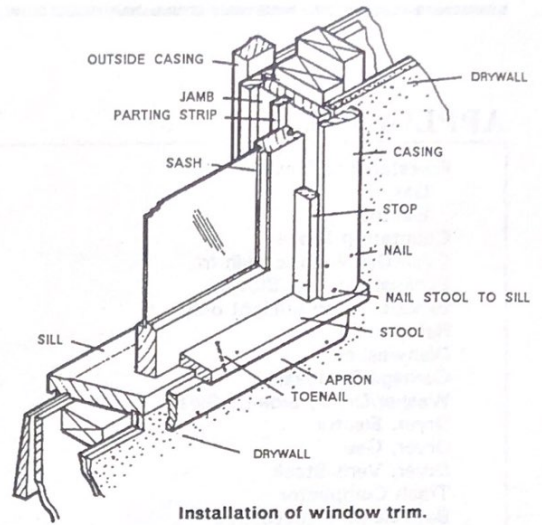

**Installation of window trim.**

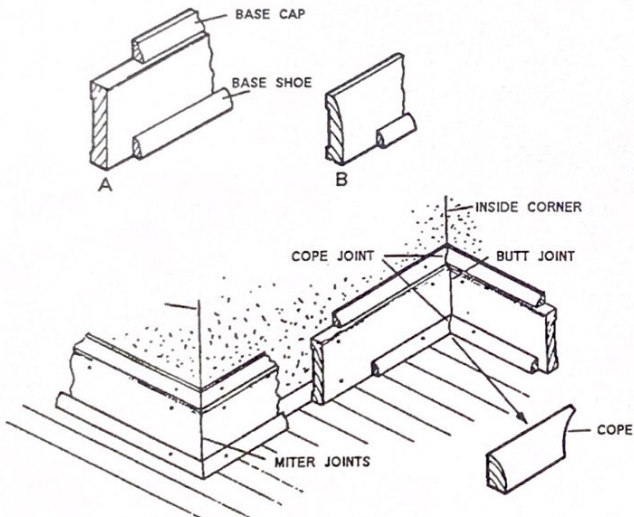

**Base molding: A, Square-edge base; B, narrow ranch base;**

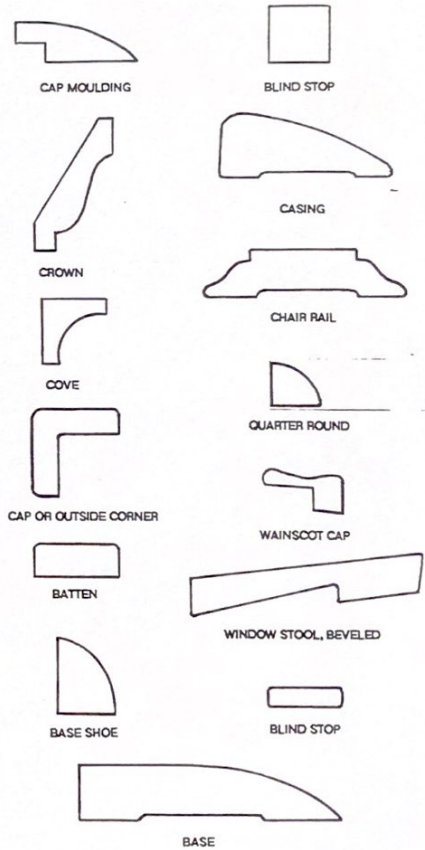

**Mouldings**

**FURNACES/FIREPLACES**

	GENERAL		LOCAL	
	Unit/Material	Labor Allowance (in hours)	Material	Unit Cost
<b>Mobile Home</b>				
Gas or Oil	Ea.	4.0		
Electric	Ea.	4.0		
Furnace Base	Ea.	1.0		
Furnace Roof Jack	Ea.	1.0		
<b>Duct Runs</b>				
Installation	LF	.1		
<hr/>				
<b>Site-Built</b>				
Upflow — Gas				
50M BTU	Ea.	3.6		
80M BTU	Ea.	4.0		
120M BTU	Ea.	6.0		
Horizontal — Gas 80M BTU	Ea.	14.0		
125M BTU	Ea.	14.5		
Oil — Upflow 85M BTU	Ea.	3.8		
Oil Horizontal 85M BTU	Ea.	4.1		
100M BTU	Ea.	5.0		
Electric, 240-Volt to 27KW	Ea.	4.0		
Electric Baseboard	LF	.3		
<b>Fireplace</b>				
Freestanding Complete	Ea.	1.5		
Freestanding Complete w/Blower	Ea.	2.0		
Wall Insert	Ea.	2.0		
Wall Insert w/Blower	Ea.	2.5		
Hotwater Baseboard	LF	.2		
Heat Pump	Ea.	4.0		

**AIR CONDITIONING**

	GENERAL		LOCAL	
	Unit/Material	Labor Allowance (in hours)	Material	Unit Cost
Window-Type	Ea.	2.5		
Central Air (furnace) — Split system	Ea.	5.0		
Freestanding — Self contained	Ea.	3.0		
Evaporative Water Cooler				
Window	Ea.	1.0		
Roof	Ea.	3.0		

**NOTES**

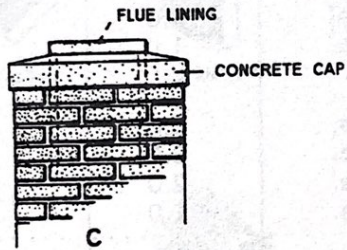
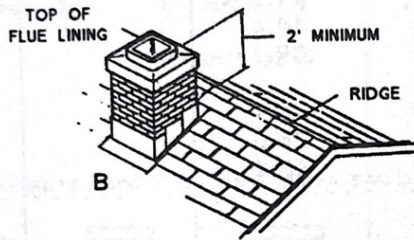
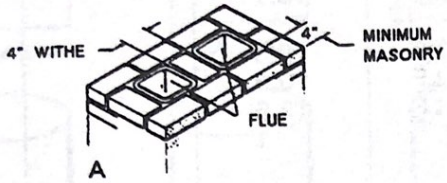

**Chimney details: A, Spacer between flues;  
 B, height of chimneys; C, chimney cap.  
 D, metal double wall chimney;  
 E, metal single wall chimney & cap**

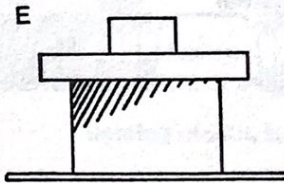
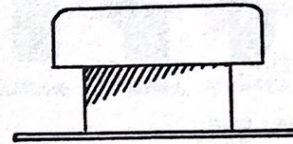
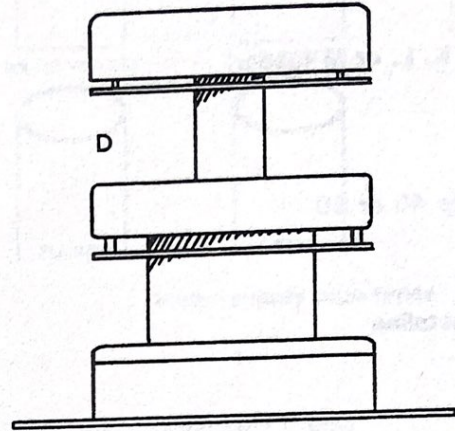

**PLUMBING**

	GENERAL		LOCAL	
	Unit/Material	Labor Allowance (in hours)	Material	Unit Cost
<b>PIPING</b> <i>(Time includes complete operation; pipe installed with hangers.)</i>				
<b>Galvanized/Black Steel Pipe</b>				
Schedule 40				
3/8"	100 LF	9.7		
1/2"	100 LF	11.9		
3/4"	100 LF	13.7		
<b>Copper Pipe K, L, or M (soder)</b>				
3/8"	100 LF	8.5		
1/2"	100 LF	10.3		
3/4"	100 LF	12.5		
<b>CPVC</b>				
PVC Schedule 40 or 80				
1 1/4"	100 LF	11.7		
2"	100 LF	14.4		
4"	100 LF	29.1		
<b>Cast Iron Wasteline</b>				
2"	100 LF	25.1		
4"	100 LF	35.5		
6"	100 LF	58.4		
<b>Toilet</b>				
Floor Mounted — Complete Assembly				
	Ea.	3.0		
Tank Only				
	Ea.	1.0		
Removal and Reset Only				
	Ea.	1.0		
<b>Sinks</b> <i>(Double compartment — add 1 hour)</i>				
Cast Iron				
	Ea.	3.0		
Enamel or Stainless Steel				
	Ea.	3.0		
Plastic				
	Ea.	2.0		
Vitreous China				
	Ea.	3.0		
<b>Sink Rim</b>				
Faucet 8"				
	Ea.	1.0		
4"				
	Ea.	.5		
	Ea.	.5		
<b>Bathtub</b>				
Cast Iron 5'				
	Ea.	6.7		
Steel Enamel 5'				
	Ea.	5.5		
Fiberglass/Plastic 5'				
	Ea.	5.5		
Plastic Tub Enclosure (modular)				
	Ea.	1.5		
Plastic Shower Enclosure w/o-base				
	Ea.	2.5		
Bathtub Fixture w/Showerhead				
	Ea.	.5		
Bathtub Enclosure Doors				
	Ea.	2.0		
<b>Water Heater</b>				
	Ea.	2.5		

**NOTES**



SOLVENT-WELDED



SOLDERED

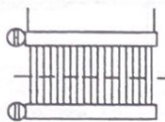

CLAMPED RUBBER GASKET

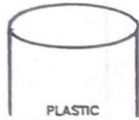

PLASTIC



COPPER

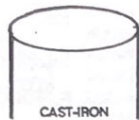

CAST-IRON

**Drainpipe types**



SOLVENT-WELDED

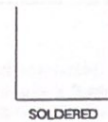

SOLDERED

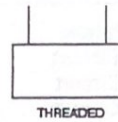

THREADED



PLASTIC



COPPER

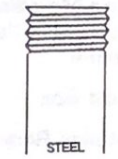

STEEL

**Water-supply pipe types**

**For galvanized and black steel, brass, and bronze pipe**



UNION



45 ELBOW



90 ANGLE



T-FITTING

**For plastic pipe (rigid)**



COUPLING



45 ELBOW



90 ELBOW



T-FITTING

**For copper pipe**



CLOSET FLANGE



45 Y BRANCH

**For copper tube (flare)**



T-FITTING



MALE ADAPTER



FEMALE ADAPTER

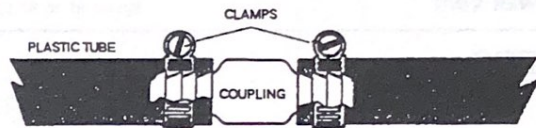

**Joining plastic tubes**

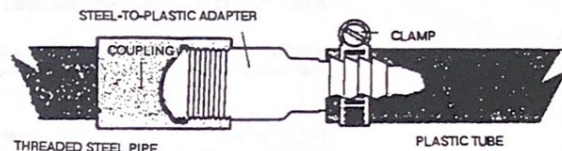

**Joining plastic to steel**

# ELECTRICAL

Times used specifically in mobile home repairs have been listed under **Mobile Home** subtitle. Times listed under **Site Built** are applicable to both mobile home and site built construction.

OPERATION	GENERAL		LOCAL	
	Unit/Material	Labor Allowance (in hours)	Material	Unit Cost
Circuit Panels				
8 Circuit	Ea.	10.5		
14 Circuit	Ea.	10.9		
20 Circuit	Ea.	11.6		
Install Non-Metallic Cable (Romex' )				
Junctions/outlets #10 and smaller	100 LF	3.0		
Amp Lifeline	Ea.	1.0		
Receptacle Box	Ea.	.2		
Single/Duplex Receptacle	Ea.	.3		
Flush Toggle Switch	Ea.	.3		
Light Fixtures				
Wall-type	Ea.	.7		
Ceiling	Ea.	1.0		
Exterior	Ea.	1.0		
Exterior vapor	Ea.	3.0		
Ceiling Fan	Ea.	1.5		
Ceiling Exhaust Fan	Ea.	1.0		
Electric Baseboard Heater — See Mechanical/Furnaces				
Sidewall Vent	Ea.	1.0		

## NOTES



**Nonmetallic and Metallic Cable**

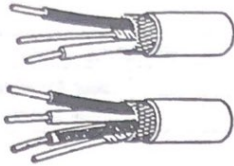

**Cable:** Individual wires can be assembled into cables. Cables are classified according to the number of wires contained and their size (gauge). For example, a "12-3" (12-3) contains three wires and a ground wire.



**Service Entrance Cable:** Service entrance cable is used to bring power to the building. Usually a 3-wire cable with the bare ground wire twisted around the two insulated wires, and all covered with a protective fabric or plastic layer.



**Nonmetallic Sheathed Cable:** Commonly referred to as NM or NMC. The former is used in dry indoor locations while the latter may be used in damp locations outdoors. It comes with and without a ground wire. Common name is "Romex". The individual wires are insulated and the entire cable is wrapped in a moisture resistant, flame resistant covering.



**Underground Cable:** Designed to be water and rust resistant. May be used underground, indoors or outdoors. Each conductor is insulated with its own moisture-resistant insulation; the several conductors are embedded in a plastic jacket which is specially resistant to mildew and corrosion.

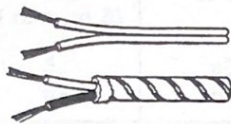

**Type T Wire:** Available in both light weight and heavy duty types. The conductor is covered by a single layer of plastic or fabric and is relatively small in overall diameter. Used in appliances, extension cords, motors, etc. Typically size 16 or 18 gauge.

**Armored and Special Purpose Cable**



**Armored Cable:** Commonly called "BX" and consists of two or more individual wires assembled into a cable which is protected by flexible steel armor. Used only in dry locations. Used with steel junction and switch boxes.

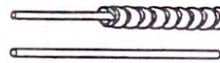

**Ground Wire:** Used to ground the electrical system to the earth either directly or via the cold water line. Size depends upon the system.

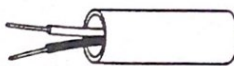

**Thin Wall Steel Conduit:** Wire or cable is pulled through this rigid piping system of ten foot sections joined by special connectors. Code required in a variety of applications. Acts as its own grounding conductor.



**Metal Wall Box**



**Metal Wall Box with Flange For Nailing**

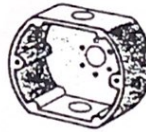

**Bakelite (Plastic) Wall Box**



**Metal Octagon Box**

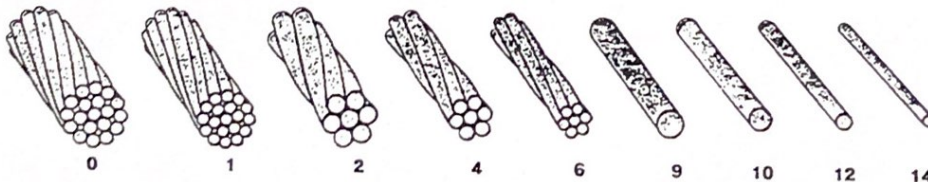

**Actual Diameter of Wire Sizes**

**FENCING**

	GENERAL		LOCAL	
	Unit/Material	Labor Allowance (in hours)	Material	Unit Cost
Picket Fence—Posts @ 6'	Section	1.0		
Split Rail—Posts @ 8'				
2 Rail	Section	1.4		
3 Rail	Section	1.4		
Plain Board Fence—Posts @ 8'	Section	1.4		
Chain Link—Posts @ 10'				
6' high	Section	2.0		
5' high	Section	1.5		
End or corner posts	Ea.	1.0		
Gate	Ea.	.5		
Barbed Wire—Posts @ 10'	Section	.5		

*NOTE: Labor allowance includes material handling, setting of posts in concrete, and erecting fence.*

**DEBRIS REMOVAL**

	GENERAL		LOCAL	
	Unit/Material	Labor Allowance (in hours)	Material	Unit Cost
Ceiling — Insulation and Framing	100 Sq. Ft.	1.5		
Ceramic Wall/Floor	100 Sq. Ft.	4.0		
Walls — Framing & Siding				
Exterior	100 Sq. Ft.	2.5		
Interior Partition	100 Sq. Ft.	2.5		
Drywall/Plaster	100 Sq. Ft.	1.5		
Under Layment, Tile, Carpet	100 Sq. Ft.	2.0		
Floor Framing	100 Sq. Ft.	2.5		

**NOTES**

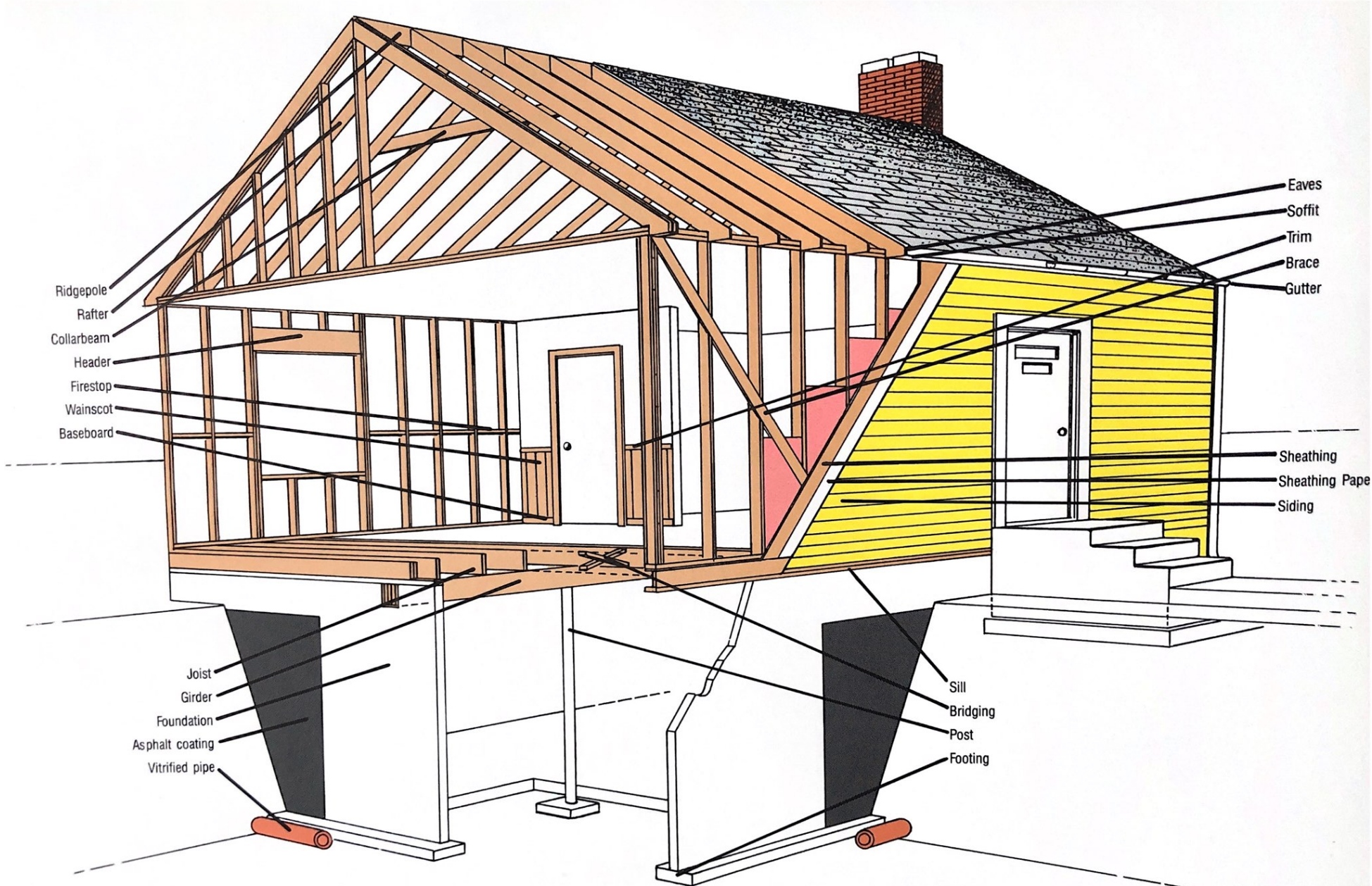

**File Attachments for Item:**

P-3 May, Terrence RBI

Certification ID# 8921

Current certifications- none

Staff notes-Unusual experience, review for equivalence. Attending meeting to discuss application.

Committee recommendation:

# Board of Building Standards

Application for Interim Certification, Building Department Personnel

May

Terrence

Last Name

First Name

BBS Certification ID

## SECTION 1: CHECK INTERIM CERTIFICATION(S) BEING REQUESTED

<input type="checkbox"/> Res. Building Official	<input type="checkbox"/> Res. Plans Examiner	<input checked="" type="checkbox"/> Res. Building Inspector
	<input type="checkbox"/> Res. Industrial Unit Inspector	<input type="checkbox"/> Res. Mechanical Inspector

## SECTION 2: LIST ANY OHIO LICENSE, CERTIFICATE, OR REGISTRATION HELD (Mark "T" If Trainee)

Description			Certificate Number	Date Received
Architectural Registration				
P.E. Registration				
Res	Non-Res			
<input type="checkbox"/>	<input type="checkbox"/>	Building Official Certification		
<input type="checkbox"/>	<input type="checkbox"/>	Plans Examiner Certification		
<input type="checkbox"/>	<input type="checkbox"/>	Building Inspector Certification		
<input type="checkbox"/>	<input type="checkbox"/>	Mechanical Inspector Certification		
Building Plans Examiner Certification				
Mechanical Plans Examiner Certification				
Fire Protection Plans Examiner Certification				
Electrical Plans Examiner Certification				
Plumbing Plans Examiner Certification				
Fire Protection Inspector Certification				
Electrical Safety Inspector Certification				
Plumbing Inspector Certification				
Fire Safety Inspector Certification				
Fire Protection System Designer Certification				
Medical Gas Piping Inspector Certification				

## Section 3: Employment/Education

a. Formal Education	Date Graduated
Putnam Vocational Tech, Eleanor, W. VA	May 1989
Ohio Lead Risk Assessors License, Ohio Licensed Lead Abatement Contractor	2018
b. Related Vocational or Technical Training	Years' Experience
Neighbor Works 240 credit Construction Management Classes.	12
c. U.S. Military construction experience (MOS or other designation):	Years' Experience
d. Place of Employment:	Years' Employed
Cleveland Action to Support Housing merged to NHS of Greater Cleveland,	16

# Board of Building Standards

Application for Interim Certification, Building Department Personnel

May

Terrence

Last Name

First Name

BBS Certification ID

## SECTION 4: OBC/RCO BUILDING INSPECTION EXPERIENCE PERFORMED FOR A BBS CERTIFIED BUILDING DEPARTMENT

BBS Certified Building Department	BBS Certified Position/Title	Duties	Date of Service, Length of Time (MM/DD/YY)

## SECTION 5: EXPERIENCE (DO NOT SUBSTITUTE WITH OTHER RESUMES).

Refer to Experience Requirements Listed in O.A.C. 4101:7-3-01 and O.R.C. 3783

Below, list the specific projects you worked on, and the specific work you performed, your typical duties for each project, and dates of this work. You must demonstrate that you have the required number of months (years) of actual, practical experience for the certification requested (see matrix).

Provide letters from certified inspectors, employers, or contractors verifying your experience. Submit copies of any certificates, diplomas, or licenses. Remove all personal information.

List Each Construction Project <u>AND</u> Specific Type of Work Performed	Name of Employer, Contact, Address, Telephone Number	Project Time: From _ To _ (MM/YY)
<p><i>Example:</i>                      Children's Hospital, Toledo                      Structural steel work on addition</p> <p>Cleveland Action to Support Housing</p> <p>Contracting Processing and monitoring and managing construction loans to program guidelines.                      Cost estimating, Spec writing, mediating claims, Warranty supervision and code enforcement, .                      Managed the renovation of 2 residential properties through the NSP program guidelines and sold the properties shortly after completion.</p>	<p>Homer Steel and Trade                      125 Anytown Street                      My City, OH, 45454                      (419)555-1212</p> <p>merged to NHS of Greater Cleveland                      5700 Broadway Ave.                      Cleveland, Ohio 44127                      (216) 458-4663</p> <p>Gretchen Bowman ED.</p>	<p>July 2013-May 2014                      (10 months)</p> <p>08/03-05/14</p>
<b>Total Experience on This Page (In Months):</b>		<b>165 Months</b>

# Board of Building Standards

Application for Interim Certification, Building Department Personnel

May

Terrence

Last Name

First Name

BBS Certification ID

## SECTION 5 CONT.: EXPERIENCE

List Each Construction Project <u>AND</u> Specific Type of Work Performed	Name of Employer, Contact, Address, Telephone Number	Project Time: From_ To _ (MM/YY)
<p>Construction specialist, Managing construction and building safety and mechanical equipment.</p> <p>Code enforcement and documentation Inspect and report for the Cuyahoga County Down Payment Assistance Program report for property conditions and potential Lead paint conditions. All aspects of maintain all building contractor vending and repairs and maintenance. 16 Unit property management for several scattered rental properties.</p> <p>Taught 3 classes for Home Buyer Education Classes, Home Inspection, Home Maintenance</p>	<p>Cleveland Action to Support Housing merged to NHS of Greater</p> <p>NHS of Greater Cleveland 5700 Broadway Ave. Cleveland, Ohio 44127 (216) 458-4663</p> <p>Gretchen Bowman ED.</p>	<p>05/14-08/19</p>
<p><b>Total Experience on This Page (In Months):</b></p>		<p><b>63 Months</b></p>

# Board of Building Standards

Application for Interim Certification, Building Department Personnel

May

Terrence

Last Name

First Name

BBS Certification ID

## SECTION 6: PERSONAL HISTORY

1. Have you ever been convicted of any felony, or any crime involving moral turpitude?  Yes  No
2. If you answered "Yes" please explain below:
3. Have you served in the U.S. armed services? (If No, skip question 3)  Yes  No
4. If YES, were you discharged under honorable conditions?  Yes  No  
If you answered "No" please explain below:

## SECTION 7: CERTIFICATION

I certify the information contained in this application is true and complete, and I understand that providing false information may be grounds for not granting certification or for immediate termination of certification at any point in the future, if granted. I authorize the investigation of all statements contained herein and release all parties from all liability for any damage that may result from furnishing the same to Ohio Board of Building Standards. Falsification is a violation of section 2921.13 of the Ohio Revised Code and is punishable as a misdemeanor of the first degree.

Signature of Applicant: 

Subscribed and duly sworn before me according to law, by the above named applicant this day 22 of August in the year 2022 at 12222 Madison Ave. County of Cuyahoga and State of Ohio.

Notary Public:  Alexander James

My commission expires  
October 4, 2025



# International Code Council

in recognition of participation in  
**2006 RESIDENTIAL CODE OF OHIO FOR ONE-, TWO-, & THREE-FAMILY DWELLINGS**

at

**CLEVELAND, OHIO**

on

**JUNE 28, 2006**

and Awards .6 ICC C.E.U.s — 6 Contact Hours

to

  
Student's Signature

  
Vice President, Training and Education

**JERRY FLANIK**  
Instructor



**State of Ohio**  
Department of Health  
Lead Program

**Lead Abatement Contractor**



License Number  
**LC12136**

Expiration Date  
**04/19/2020**

**Terrence M May**

**1449 Rockway Ave**  
**Lakewood OH 44107**

Card not valid if altered

This certification is issued pursuant of Chapter 3742 of the Revised Code and 3701-32 of the Ohio Administrative Code

**State of Ohio**  
Department of Health  
Lead Program

**Lead Risk Assessor**



License Number  
**LA9475**

Expiration Date  
**10/25/2020**

**Terrence M May**

**1449 Rockway Ave**  
**Cleveland OH 44107**

Card not valid if altered

This certification is issued pursuant of Chapter 3742 of the Revised Code and 3701-32 of the Ohio Administrative Code

# CERTIFICATE OF COMPLETION

**Terrence M. May**

has satisfactorily completed

~~Building Science~~ Basics for Construction and Rehab

at the

NeighborWorks Training Institute

Orlando, FL

August 20, 2014



A handwritten signature in black ink, appearing to read "John McCloskey".

JOHN McCLOSKEY  
Vice President, Training

# CERTIFICATE OF COMPLETION

**Terrence M. May**

has satisfactorily completed  
Healthy Housing in Construction and Rehab

at the

NeighborWorks Training Institute  
Orlando, FL

August 21 - 22, 2014



A handwritten signature in black ink, consisting of several loops and a horizontal line at the end.

JOHN McCLOSKEY  
Vice President, Training

# Certificate of Completion

**Terrence M. May**

has satisfactorily completed

Homeowner Rehab: Working with Homeowners, Contractors, Inspectors On Challenging Homes

at the

NeighborWorks® Training Institute

Cincinnati, OH

May 8 - 9, 2008



*Kenneth D. Wade*

**KENNETH D. WADE**  
Chief Executive Officer  
NeighborWorks® America

*Paul Webb*

**INSTRUCTOR**



# Certificate of Completion

**Terrence M. May**

has satisfactorily completed  
Housing Production Management  
at the

NeighborWorks® Training Institute  
Cincinnati, OH  
May 5 - 6, 2008



*Kenneth D. Wade*

**KENNETH D. WADE**  
Chief Executive Officer  
NeighborWorks® America

*Carol M. Myrtle*

**INSTRUCTOR**



# Certificate of Completion

**Terrence May**

has satisfactorily completed  
Cost Estimation for Rehab Specialists  
at the  
NeighborWorks® Training Institute  
Dallas, TX  
April 5, 2006



*Kenneth D. Wade*

KENNETH D. WADE  
Chief Executive Officer  
NeighborWorks® America

*R. M. Smith*

INSTRUCTOR

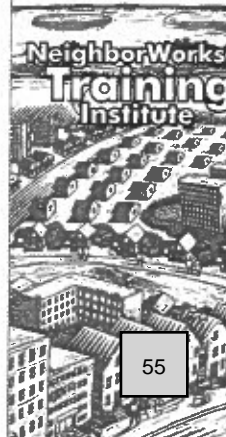

# Certificate of Completion

**Terrence May**

has satisfactorily completed  
Design and Specification for Rehab Specialists  
at the  
NeighborWorks® Training Institute  
Dallas, TX  
April 3 - 4, 2006



*Kenneth D. Wade*

KENNETH D. WADE  
Chief Executive Officer  
NeighborWorks® America

*R. M. Austin*

INSTRUCTOR

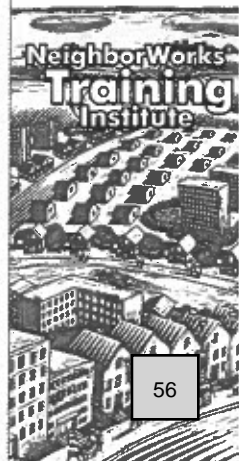



# Certificate of Completion

**Terrence May**

has satisfactorily completed

Rehab Management

at the

NeighborWorks® Training Institute

Dallas, TX

April 6 - 7, 2006



*Kenneth D. Wade*

KENNETH D. WADE  
Chief Executive Officer  
NeighborWorks® America

*R.M. Auth*

INSTRUCTOR



# CERTIFICATE OF COMPLETION

**Terrence M. May**

has satisfactorily completed  
Sustainable Design for Construction and Rehab

at the  
NeighborWorks Training Institute  
Orlando, FL

August 18 - 19, 2014



A handwritten signature in black ink, appearing to read "John McCloskey", written over a horizontal line.

JOHN McCLOSKEY  
Vice President, Training

# CERTIFICATE OF COMPLETION

**Terrence M. May**

has satisfactorily completed

Greening Housing Rehab

at the

NeighborWorks® Training Institute

Chicago, IL

August 17 - 18, 2009



*Kenneth D. Wade*

**KENNETH D. WADE**  
Chief Executive Officer  
NeighborWorks® America

*Paul Kealey*

**PAUL KEALEY**  
Director  
NeighborWorks® America, Training Division



# Certificate of Completion

**Terrence M. May**

has satisfactorily completed

Building Multifamily Housing Part III: Project Managing the Construction Process

at the

NeighborWorks® Training Institute

Phoenix, AZ

May 10 - 11, 2007



*Kenneth D. Wade*

**KENNETH D. WADE**  
Chief Executive Officer  
NeighborWorks® America

*William K. Army*

**INSTRUCTOR**



# Certificate of Completion

**Terrence M. May**

has satisfactorily completed  
**Housing Production Management**  
at the

**NeighborWorks® Training Institute**

**Cincinnati, OH**

**May 5 - 6, 2008**

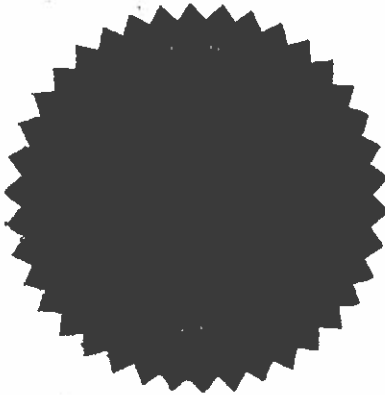

*Kenneth D. Wade*

**KENNETH D. WADE**  
Chief Executive Officer  
NeighborWorks® America

*Carol M. Mayall*

**INSTRUCTOR**



# Certificate of Completion

**Terrence M. May**

has satisfactorily completed

Homeowner Rehab: Working with Homeowners, Contractors, Inspectors On Challenging Homes

at the

NeighborWorks® Training Institute

Cincinnati, OH

May 8 - 9, 2008



*Kenneth D. Wade*

**KENNETH D. WADE**  
Chief Executive Officer  
NeighborWorks® America

*Paul Webb*

**INSTRUCTOR**



# Certificate of Completion

**Terrence May**

has satisfactorily completed  
Cost Estimation for Rehab Specialists  
at the  
NeighborWorks® Training Institute  
Dallas, TX  
April 5, 2006



*Kenneth D. Wade*

KENNETH D. WADE  
Chief Executive Officer  
NeighborWorks® America

*R. M. Smith*

INSTRUCTOR



# Certificate of Completion

**Terrence May**

has satisfactorily completed  
Design and Specification for Rehab Specialists  
at the  
NeighborWorks® Training Institute  
Dallas, TX  
April 3 - 4, 2006



*Kenneth D. Wade*

KENNETH D. WADE  
Chief Executive Officer  
NeighborWorks® America

*R. M. Austin*

INSTRUCTOR





# Certificate of Completion

**Terrence May**

has satisfactorily completed

Rehab Management

at the

NeighborWorks® Training Institute

Dallas, TX

April 6 - 7, 2006



*Kenneth D. Wade*

KENNETH D. WADE  
Chief Executive Officer  
NeighborWorks® America

*R.M. Austin*

INSTRUCTOR



# Terrence M. May

---

[REDACTED]  
[REDACTED]  
[REDACTED] terrencemay@gmail.com

## OBJECTIVE

---

Seeking a position where I can maximize my 10+ years of management, quality assurance, program development and training, construction and cost estimating experience.

## EXPERIENCE

---

2021 to present

### **Project Developer, Hurst Design Build Remodel**

*Duties include:* Creates all contract documents required for the successful production of each remodeling project. This includes; conducting site inspections with the design team, performing accurate take offs, securing detailed quotes from vendors and trades, compiling estimates and specifications for the production teams execution, and generating purchase orders.

2019 to 2021

### **Project Estimator, Roth Construction**

*Duties include:* Inspecting, scoping and sketching insurance loss claims to Insurance carriers criteria. Implementing local codes and state codes to reconstruct the loss to the properties.

*Using xactimate and xactanalysis to communicate with insurance adjusters and third party administrators. Writing project contracts and supplements regarding the project's cost and work related needs. Sampling building materials to match like and kind for pricing and replacing the building materials needed to estimate the projects needs.*

2014 to 2019

### **Construction specialist, NHS of Greater Cleveland**

*Duties include:* Contracting Processing and monitoring and managing construction loans to program guidelines.

Cost estimating, Spec writing, mediating claims, Warranty supervision and code enforcement

Inspect and report for the Cuyahoga County Down Payment Assistance Program report for property conditions and potential Lead paint conditions.

All aspects of maintain all building contractor vending and repairs and maintenance.

16 Unit property management for several scattered rental properties.

In house computer assistance, office technical support.

Accounting and managing construction accounts and payment draws from customer escrow accounts.

Report Monthly to Loan Committee for loan approvals and witnesses and conditions of construction loans

Taught 3 classes for Home Buyer Education Classes, Home Inspection, Home Maintenance and Lead Awareness classes

2003 to 2014

**Construction Manager, Cleveland Action to Support Housing**

*Duties include:* Contracting Processing and monitoring and managing construction loans to program guidelines.

Cost estimating, Spec writing, mediating claims, Warranty supervision and code enforcement, technical applications and maintenance of office computer systems.

Managed the renovation of 2 residential properties through the NSP program guidelines and sold the properties shortly after completion.

1998 to 2003

**Building Maintenance, PSF Management**

*Duties include:* Maintaining 3 office buildings downtown Cleveland

Other duties include routine and preventative maintenance of all mechanical and building structures, build-outs and demo. Oversee asbestos abatement contract work performed.

## EDUCATION

---

2010 to present

HUD 203K Consultant, Lead Certified Renovators License Since 2010

2018

Ohio Lead Risk Assessors License, Ohio Licensed Lead Abatement Contractor

2006

240 credit hours continuing my Construction Management Classes.  
6 credit hours Ohio Revised Building Code at Tri-C Corporate College

2005

16 credit hours Windows Access Database classes at Devour Computer Training

2001

HVAC Refrigeration certification training

1992

West Virginia State College

1989

Putnam Vocational Tech, Eleanor, W. VA

**File Attachments for Item:**

P-4 Furry, Mark ESI Trainee - Alternative Trainee Plan

Certification ID# 8882

Current certifications- none

Staff notes-Approved for exams August 2022. Alternative trainee plan provides for study time and appropriate supervision, terminating upon completion of exams and Code Academy. Recommend approval.

Committee recommendation:

# Board of Building Standards

Application for Trainee Certification, Building Department Personnel

FURRY  
Last Name

MARK  
First Name

8882  
BBS Certification ID

## SECTION 1: CHECK TRAINEE CERTIFICATION(S) BEING REQUESTED

<input type="checkbox"/> Building Official	<input type="checkbox"/> Master Plans Examiner	<input type="checkbox"/> Building Inspector	<input checked="" type="checkbox"/> Electrical Safety Inspector	<input type="checkbox"/> Fire Protection Inspector
<input type="checkbox"/> Building Plans Examiner	<input type="checkbox"/> Plumbing Plans Examiner	<input type="checkbox"/> Mechanical Plans Examiner	<input type="checkbox"/> Electrical Plans Examiner	<input type="checkbox"/> Fire Protection Plans Examiner
	<input type="checkbox"/> Plumbing Inspector	<input type="checkbox"/> Mechanical Inspector	<input type="checkbox"/> Non-Residential Industrial Unit Inspector	

<input type="checkbox"/> Res. Building Official	<input type="checkbox"/> Res. Plans Examiner	<input type="checkbox"/> Res. Building Inspector
	<input type="checkbox"/> Res. Industrial Unit Inspector	<input type="checkbox"/> Res. Mechanical Inspector

## SECTION 2: LIST ANY OHIO LICENSE, CERTIFICATE, OR REGISTRATION HELD (Mark "T" If Trainee)

Description		Certificate Number	Date Received
Architectural Registration			
P.E. Registration			
Res	Non-Res		
<input type="checkbox"/>	<input type="checkbox"/>	Building Official Certification	
<input type="checkbox"/>	<input type="checkbox"/>	Plans Examiner Certification	
<input type="checkbox"/>	<input type="checkbox"/>	Building Inspector Certification	
<input type="checkbox"/>	<input type="checkbox"/>	Mechanical Inspector Certification	
Building Plans Examiner Certification			
Mechanical Plans Examiner Certification			
Fire Protection Plans Examiner Certification			
Electrical Plans Examiner Certification			
Plumbing Plans Examiner Certification			
Fire Protection Inspector Certification			
Electrical Safety Inspector Certification		8882	8/26/22
Plumbing Inspector Certification			
Fire Safety Inspector Certification			
Fire Protection System Designer Certification			
Medical Gas Piping Inspector Certification			

## Section 3: Employment/Education

a. Formal Education	Date Graduated
<u>BUCYRUS HIGH SCHOOL</u>	<u>5/1982</u>
<u>900 FERRY STREET, BUCYRUS OHIO 44820</u>	

**Board of Building Standards**

Application for Trainee Certification, Building Department Personnel

FURRY  
Last Name

MARK  
First Name

8882  
BBS Certification ID

b. Related Vocational or Technical Training	Years' Experience
<i>PIONEER CAREER + TECHNOLOGY CENTER</i>	<i>1 1/2 YR.</i>
<i>27 RYAN RD, SHELBY, OHIO 44875 (Comp/Business)</i>	
c. U.S. Military construction experience (MOS or other designation):	Years' Experience
<i>N/A</i>	
d. Place of Employment: <i>LICKING COUNTY BUILDING CODE</i>	Years' Employed
<i>675 PRICE ROAD, NEWARK, OHIO 43055</i>	<i>8/8/2022 - PRESENT</i>

**SECTION 4: OBC/RCO BUILDING INSPECTION EXPERIENCE PERFORMED FOR A BBS CERTIFIED BUILDING DEPARTMENT**

BBS Certified Building Department	BBS Certified Position/Title	Duties	Date of Service, Length of Time (MM/DD/YY)

**SECTION 5: EXPERIENCE (DO NOT SUBSTITUTE WITH OTHER RESUMES).**

Refer to Experience Requirements Listed in O.A.C. 4101:7-3-01 and O.R.C. 3783

Below, list the specific projects you worked on, and the specific work you performed, your typical duties for each project, and dates of this work. You must demonstrate that you have the required number of months (years) of actual, practical experience for the certification requested (see matrix).

Provide letters from certified inspectors, employers, or contractors verifying your experience. Submit copies of any certificates, diplomas, or licenses. Remove all personal information.

List Each Construction Project AND Specific Type of Work Performed	Name of Employer, Contact, Address, Telephone Number	Project Time: From_ To _ (MM/YY)
<i>Example: Children's Hospital, Toledo Structural steel work on addition</i>	<i>Homer Steel and Trade 125 Anytown Street My City, OH, 45454 (419)555-1212</i>	<i>July 2013-May 2014 (10 months)</i>
Total Experience on This Page (In Months):		

# Board of Building Standards

Application for Trainee Certification, Building Department Personnel

FURRY

Last Name

MARK

First Name

8882

BBS Certification ID

## SECTION 5 CONT.: EXPERIENCE

List Each Construction Project AND Specific Type of Work Performed	Name of Employer, Contact, Address, Telephone Number	Project Time: From_ To _ (MM/YY)
<p>78 NAUTICAL WAY, BUCKEYE LAKE (NEW BUILD SINGLE FAMILY DWELLING)</p> <p>DESIGNED ELECTRICAL LAYOUT, INSTALLED ALL ELECTRICAL CONDUITS PULLED ALL CIRCUITS REWARD METER BOX AND PANELBOARD INSTALLED GFCI AND ARC FAULT PER CODE REQUIREMENTS. PERFORMED CALCULATIONS ON LOADS FOR PROPER BALANCE. PERFORMED CALCULATIONS ON BOX FILL CODE REQ. INSTALLED ON REQUIRED TAMPER-PROOF REQUIRED RECEPTACLES. (DID PROJECT FROM ROUGH TO FINISH BY MYSELF)</p>	<p>ONE-WAY ELECTRIC LLC 466 SHERWOOD DR. EAST NEWARK, OH 43055 (MY OWN COMPANY)</p> <p>CUSTOMER CONTACT: LISA + KEVIN BOHAN (614) 203-1799</p>	<p>MARCH 2022 - JULY 2022 (4 MONTHS)</p>
<p>72 1/2 / 74 / 74 1/2 N. OHIO AVE COLUMBUS, OHIO (SINGLE-FAMILY DWELLINGS)</p> <p>LAID OUT ELECTRICAL DESIGN FOR ALL UNITS. BUILT 4 GANG SERVICE, PANEL INSTALLATION FOR ALL 4 UNITS. PERFORMED ALL CALCULATIONS FOR LOADS. DID REQUIRED GROUNDING/BONDING PER NEC REQUIREMENTS. AWARDED AND LANDED WIRING FOR HVAC UNITS. COMPLETED PROJECT FROM ROUGH TO FINISH.</p>	<p>ONE-WAY ELECTRIC LLC 466 SHERWOOD DR. EAST NEWARK, OHIO 43055</p> <p>CUSTOMER: THE PHOENIX GROUP 3387 SNOUFFER RD, COLUMBUS</p> <p>CONTACT: FRED VERKSER (614) 588-5241</p>	<p>5/17-12/2020 <del>2020</del> (43 MONTHS)</p>
<p>FED-EX DISTRIBUTION CENTER 4600 POTH RD, COLUMBUS, OH.</p> <p>PULLED WIRE, RAN AND BENT CONDUIT, USED SNORKEL LIFT. SET JUNCTION BOXES FOR WIRE TERMINATION, INSTALLED LARGE INDUSTRIAL FANS. INSTALLED AND WIRED VARIABLE FREQUENCY DRIVES (VFD).</p>	<p>CUSTOM AIR HEATING + COOLING 935 CLAYCRAFT RD, COLUMBUS, OHIO (614) 552-4822</p>	<p>JULY 2015 - SEPT 2015 (3 MONTHS)</p>
Total Experience on This Page (In Months):		

**Board of Building Standards**

Application for Trainee Certification, Building Department Personnel

FURRY  
Last Name

MARK  
First Name

8882  
BBS Certification ID

**SECTION 5 CONT.: EXPERIENCE**

List Each Construction Project AND Specific Type of Work Performed	Name of Employer, Contact, Address, Telephone Number	Project Time: From_ To _ (MM/YY)
<p><b>BOB EVANS RESTAURANTS</b> STATES: OHIO, INDIANA, VIRGINIA, DELAWARE, MARYLAND, NEW YORK, PENNSYLVANIA, MISSOURI, MICHIGAN. INSTALLED ELECTRIC FOR NEW HVAC ROOFTOP UNITS SET NEW DISCONNECTS FOR EACH UNIT, TERMINATED WIRING TO RUN EACH UNIT INSTALLED CONTACTORS REWORKED CONDUIT.</p>	<p><b>GRIFFS ELECTRIC</b> 7535 PICKERINGTON RD. CANAL WINCHESTER  <b>G+F ELECTRIC</b> 6567 BROCK ST. DUBLIN, OHIO (OWNED COMPANY)</p>	<p><b>JUNE 2004 - SEPT 2016</b> (144 MONTHS)</p>
<p><b>LUXURY POOLS AND LIVING</b> INSTALL ALL REQUIRED ELECTRIC, GROUNDING AND BONDING FOR NEW POOLS AND HOT TUBS. INSTALLED POOL PANELS, LAYED PVC CONDUIT, PULLED WIRE RAN CALCULATIONS TO SUPPORT POOL PANELS.</p>	<p><b>LUXURY POOLS AND LIVING</b> 1605 SHAWNEE AVE. COLUMBUS OHIO CONTACT: MATTHEW RAY (614) 890-7665  <b>G+F ELECTRIC</b> 6567 BROCK ST. DUBLIN, OH (OWNED COMPANY)</p>	<p><b>SEPT 2012 - MAY 2014</b></p>
<p><b>* I DO HOLD AN OHIO ELECTRICAL LICENSE (EL # 46333 - SINCE 2011)</b></p>		
<p><b>* I HAVE BEEN DOING ELECTRIC IN THE FIELD SINCE 2003. I STARTED AS AN APPRENTICE AND THEN BECAME AN ELECTRIC CONTRACTOR.</b></p>		
<p>Total Experience on This Page (In Months):</p>		



**Board of Building Standards**

Application for Trainee Certification, Building Department Personnel

FURRY  
Last Name

MARK  
First Name

8892  
BBS Certification ID

**SECTION 6: PERSONAL HISTORY**

- 1. Have you ever been convicted of any felony, or any crime involving moral turpitude?  
If you answered "Yes" please explain below:  Yes  No
- 2. Have you served in the U.S. armed services? (If No, skip question 3)  Yes  No
- 3. If YES, were you discharged under honorable conditions?  
If you answered "No" please explain below:  Yes  No

**SECTION 7: CERTIFICATION**

*I certify the information contained in this application is true and complete, and I understand that providing false information may be grounds for not granting certification or for immediate termination of certification at any point in the future, if granted. I authorize the investigation of all statements contained herein and release all parties from all liability for any damage that may result from furnishing the same to Ohio Board of Building Standards. Falsification is a violation of section 2921.13 of the Ohio Revised Code and is punishable as a misdemeanor of the first degree.*

Signature of Applicant: Mark A. Furry

Subscribed and duly sworn before me according to law, by the above named applicant this day 14<sup>th</sup> of Sept. in the year 2022 at 9:00 am, County of Licking and State of Ohio.



**CHRISTEL HAMPER**  
Notary Public, State of Ohio  
My Commission Expires  
05-13-2023

Notary Public: Christel Hamper

**Board of Building Standards**

Application for Trainee Certification, Building Department Personnel

Furry  
Last Name

Mark  
First Name

8882  
BBS Certification ID

**SUPERVISOR CERTIFICATION OF TRAINEE**

*Please complete this certification and return it with the BBS Application for Trainee Certification.*

Application for participation in a BBS trainee program is being made to the Board of Building Standards. I, Phillip Troy Warnock, trainee supervisor for the political subdivision of Licking County, (Municipality, Township, County) hold certification as a Building Official, Certification ID# 2295, effective until June 30, 2024, and hereby consent and agree to supervise the work of Mark Furry (Applicant) as a Building Department Trainee pursuant to section 4101:7-3-01(F)(5)(b) of the Ohio Administrative Code.

Number of Trainees presently supervised (including this applicant):

       One                Two

Signature:  Date: 09/14/22

**Board of Building Standards**

Application for Trainee Certification, Building Department Personnel

Furry  
Last Name

Mark  
First Name

8882  
BBS Certification ID

**BUILDING OFFICIAL CERTIFICATION OF  
TRAINEE AND SUPERVISOR**

*Please complete this certification and return it with the BBS Application for Trainee Certification*

Application for participation in a BBS Trainee program is being made to the Board of Building Standards. I, Phillip Troy Warnock, Building Official for the political subdivision of Licking County (Municipality, Township, County) do hereby acknowledge that the applicant, Mark Furry, and the assigned supervisor, myself - Phillip Troy Warnock are full-time employees of the above mentioned political subdivision.

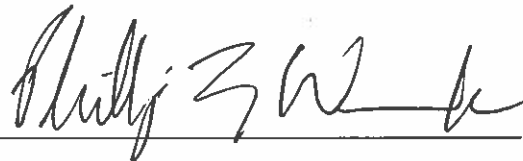
Signature:  Date: 09/14/22

**Board of Building Standards**

Application for Trainee Certification, Building Department Personnel

Furry  
Last Name

Mark  
First Name

8882  
BBS Certification ID

**OPTIONAL ALTERNATIVE TRAINEE PROGRAM PLAN FORM**

*Building Official, Supervisor and Applicant shall complete and submit this form with BBS Application for Trainee Certification only if Trainee Sponsor is proposing an alternative trainee program in lieu of the requirements of the traditional trainee program specified in OAC 4101:7-3-01(F)(5)(e). No Alternative Trainee Program may propose to waive examination requirements or attendance at the OBCA.*

**PROPOSED ALTERNATIVE PROGRAM PLAN DESCRIPTION**

*Attach additional pages if necessary and/or a letter describing the proposed program conditions.*

Proposed Alternative Program Length: Completion no later than December 31, 2023

Proposed Alternative Program Education Requirements: Mark shall complete the Code Academy within the program length, as well as devote 25% of the work week studying/preparing for the commercial electrical inspector exam.

Proposed Alternative Program Training & Supervision Requirements: Mark will primarily conduct inspections relating to residential and multi-family construction. He will also work closely with our current full-time ESI, Bill Betscher, to assist in conducting inspections for non-residential projects. Field supervision and follow-up will be done by our Chief Building Inspector, Jim Camp, and by myself. I will also work closely with Mark to make sure he completes all interim requirements.

Explanation of how the Proposed Alternative Program provides equivalent level of training and education based on the Applicant's experience documented in the application: \_\_\_\_\_

Mark has been approved by the Board to take his exams. He has passed the NCPCCI 2A exam, but missed the 2B exam by 3 percentage points. Therefore, he has demonstrated his knowledge through experience and testing of the residential electrical requirements, and is extremely close to passing the final exam. The alternate program will allow Mark to inspect residential work while continuing to prepare for passage of the 2B exam.

Applicant Signature: *Mark A. Furry* Date: 9/14/22

Supervisor Signature: *Phillip ZW* Date: 09/14/22

Building Official Signature: *Phillip ZW* Date: 09/14/22

ELECTRICAL SAFETY INSPECTOR  
APPROVAL TO SIT FOR THE EXAMS

August 26, 2022

Mark Furry

RE: Personnel I.D. No. 8882

Dear Mr. Furry,

This letter is to inform you that the Board of Building Standards has given you approval to take the Electrical Safety Inspector (ESI) exams. It is your responsibility to contact one of the testing groups listed below and arrange to take the required examinations.

- National Certification Program for Construction Code Inspectors (NCPCCI)  
Telephone #: 1-877-228-3926  
[www.provexam.com/register](http://www.provexam.com/register)  
Required exams **2A & 2B**
- The International Code Council (ICC)  
National Certification Services (NCS)  
Telephones #: 1- 888-422-7233  
[www.iccsafe.org](http://www.iccsafe.org)  
Required exams **E1 & E2**

**After you have successfully passed the required examinations, please forward your proof of passing results to Amy Jones at Board of Building Standards ([amy.jones@com.state.oh.us](mailto:amy.jones@com.state.oh.us)), and upon receipt you will be granted an interim certification to serve as an ESI.**

**You must complete the Ohio Building Code Academy requirements during the two-year interim certification granted by the Board. After you receive your Certificate of Completion for the Ohio Building Code Academy you may apply for a full certification as an Electrical Safety Inspector.**

**To apply for full certification, you will need to complete a new FULL application, attach a copy of your Certificate of Completion for the Ohio Building Code Academy and submit it to the Board of Building Standards. NO FEE!**



Please refer to your personnel **I.D. No. 8882** on any correspondence and on all certificates of continuing education forwarded to this office relating to your certification. If you have any questions, please do not hesitate to contact this office at (614) 644-2613.

Sincerely,

BOARD OF BUILDING STANDARDS

Regina S. Hanshaw  
Executive Secretary

RSH/alj

**File Attachments for Item:**

P-5 Holbert Jr., Harry - BI, RBO

Cert ID: 4776

Current Certifications: None, previously held BI, FPI, RBO

Staff Notes: In communication with applicant, as application does not agree with cover letter as to certifications requested.

Committee Recommendation:

September 12, 2022

Ohio Board of Building Standards  
6606 Tussing Road  
PO Box 4009  
Reynoldsburg, Ohio 43068-9009 U.S.A

Re: Application for Certification of Building Department Personnel

Dear Personnel Committee and Board Members,

Please accept this letter and Applications for Certification of Building Department Personnel. I am respectfully requesting review of my application for Building Inspector and Residential Building Official. Over the past 30 plus years I have enjoyed working in the constructions industry and the knowledge received from those around me. I have faced many challenges including cancer shortly after receiving my Interim Building Inspector and Residential Building Official and look forward to getting back to work. My work experience ranges from design and supervision of simple residential projects to design and supervising multidiscipline commercial projects. I feel if given the opportunity to advance to these roles, I could provide the dedication and expertise required.

Thank-you for this opportunity and should you have any questions, please do not hesitate to contact me.

Sincerely,



Harry L. Holbert Jr.

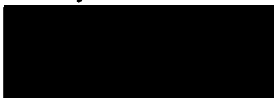



**SECTION 1: CHECK INTERIM CERTIFICATION(S) BEING REQUESTED**

<input checked="" type="checkbox"/> Building Official	<input checked="" type="checkbox"/> Master Plans Examiner	<input checked="" type="checkbox"/> Building Inspector	<input type="checkbox"/> Electrical Safety Inspector	<input type="checkbox"/> Fire Protection Inspector
<input type="checkbox"/> Building Plans Examiner	<input type="checkbox"/> Plumbing Plans Examiner	<input type="checkbox"/> Mechanical Plans Examiner	<input type="checkbox"/> Electrical Plans Examiner	<input type="checkbox"/> Fire Protection Plans Examiner
	<input type="checkbox"/> Plumbing Inspector	<input type="checkbox"/> Mechanical Inspector	<input type="checkbox"/> Non-Residential Industrial Unit Inspector	

**SECTION 2: LIST ANY OHIO LICENSE, CERTIFICATE, OR REGISTRATION HELD**

(Mark "T" If Trainee)

Description		Certificate Number	Date Received
Architectural Registration			
P.E. Registration			
Res	Non-Res		
<input checked="" type="checkbox"/>	<input type="checkbox"/>	Building Official Certification	4776 12/31/2015
<input type="checkbox"/>	<input type="checkbox"/>	Plans Examiner Certification	
<input type="checkbox"/>	<input checked="" type="checkbox"/>	Building Inspector Certification	4776 1/31/2016
<input type="checkbox"/>	<input type="checkbox"/>	Mechanical Inspector Certification	
Building Plans Examiner Certification			
Mechanical Plans Examiner Certification			
Fire Protection Plans Examiner Certification			
Electrical Plans Examiner Certification			
Plumbing Plans Examiner Certification			
Fire Protection Inspector Certification		4776	4/30/2016
Electrical Safety Inspector Certification			
Plumbing Inspector Certification			
Fire Safety Inspector Certification			
Fire Protection System Designer Certification			
Medical Gas Piping Inspector Certification			

**Holbert, Jr.**

**Harry Lee**

**4776**

*Last Name*

*First Name*

*BBS Certification ID*

**SECTION 3: EMPLOYMENT/EDUCATION**

Formal Education	Date Graduated
University of Cincinnati	N/A
Xavier University	2012
Related Vocational or Technical Training	Years' Experience
Cincinnati State Technical and Community College	15
Live Oaks Career Campus	4
U.S. Military construction experience (MOS or other designation):	Years' Experience
	N/A
Place of Employment:	Years' Employed
Warren County Building Department	1
Goshen Township	3

**SECTION 4: APPLICANTS REQUESTING MEDICAL GAS INSPECTOR CERTIFICATION**

**Attach proof** of certification by an ASSE recognized third-party certifier in accordance with ASSE standard 6020.

**SECTION 5: OBC BUILDING INSPECTION EXPERIENCE PERFORMED FOR A BBS CERTIFIED BUILDING DEPARTMENT**

BBS Certified Building Department	BBS Certified Position/Title	Duties	Date of Service, Length of Time (MM/DD/YY)

Holbert, Jr  
Last Name

Harry L.  
First Name

4776  
BBS Certification ID

**SECTION 6: ELECTRICAL SAFETY INSPECTOR (ESI) - SPECIFIC EXPERIENCE QUALIFICATIONS**

Applicants for Electrical Safety Inspector Only Must Complete This Item

Section 3783 of the Ohio Revised Code specifies that an applicant for a Certificate of Competency as an Electrical Safety Inspector must meet one of the following to qualify to take required examination. Please check the qualification that applies:

1.  Have been a journeyman electrician or equivalent for four years, two of which were as an electrician foreman, and have had two years' experience as a building department electrical inspector trainee;
2.  Have been a journeyman electrician or equivalent for four years and have had three years' experience as a building department electrical inspector trainee;
3.  Have had for four years' experience as a building department electrical inspector trainee;
4.  Have been a journeyman electrician or equivalent for six years;
5.  Am a graduate electrical engineer and registered in the State of Ohio. Registration number: \_\_\_\_\_
6.  Applicant authorizes all testing organizations including ICC to provide test results to the BBS.

**SECTION 7: EXPERIENCE (Do NOT SUBSTITUTE WITH OTHER RESUMES).**

Refer to Experience Requirements Listed in O.A.C. 4101:7-3-01 and O.R.C. 3783

Below, list the specific projects you worked on, and the specific work you performed, your typical duties for each project, and dates of this work. You **must** demonstrate that you have the required number of months (years) of actual, practical experience for the certification requested (see matrix).

Provide letters from certified inspectors, employers, or contractors verifying your experience. Submit copies of any certificates, diplomas, or licenses. Remove all personal information.

**SECTION 7 CONT.: EXPERIENCE**

List Each Construction Project <u>AND</u> Specific Type of Work Performed	Name of Employer, Contact, Address, Telephone Number	Project Time: From_ To _ (MM/YY)
<i>Example:</i> Children's Hospital, Toledo Structural steel work on addition	Homer Steel and Trade 125 Anytown Street My City, OH, 45454 (419)555-1212	July 2013-May 2014 (10 months)
<b>Total Experience on This Page (In Months):</b>		



# Board of Building Standards

## APPLICATION FOR CERTIFICATION OF BUILDING DEPARTMENT PERSONNEL

Page 3 (You may make additional copies of this page if necessary.)

**8. EXPERIENCE (CONT.):** Refer to Experience Requirements Listed in 4101:1-1-01 OAC and 3783 ORC (DO NOT SUBSTITUTE WITH OTHER RESUMES). State the specific duties and type of work performed for each position listed. Give only information which relates directly to the information you provide. Provide letters from certified inspectors, employers, or contractors verifying your experience. Submit copies of any certificates, diplomas, or licenses received.

List Each Construction Project AND Specific Type of Work Performed	OBC Group	Name of Employer, Address, Telephone Number	Project Time: From_To_ (MM/DD/YY)
The Woodlands Building Designer Provided design services to owner for 4-unit buildings for small development (about 20 separate units).	2000 IRC R3 A-2	Hc Design Group, LTD. 6235 Fay Court, Suite H Loveland, Ohio 45140 513-774-9099	3-2 to 8-4 (5 mts)
Compass Point Condominiums Community Building Building Designer and project consultant. Provided design service and inspections of footing, foundation and retaining walls, framing, building structure, truss system and ADA review to owner.	2002 OBC VB A-3	Hc Design Group, LTD. 6235 Fay Court, Suite H Loveland, Ohio 45140 513-774-9099	6-2 to 11-2 (5 mts)
SportsPlus Concession Stand remodel Building Designer and project consultant. Provided design service and inspections of footing, foundation, framing, concrete and metal works. Reviewed cut sheets and shop drawings as owners rep.	2002 OBC A4 & M	Hc Design Group, LTD. 6235 Fay Court, Suite H Loveland, Ohio 45140 513-774-9099	11-4 to 6-5 (5 mts)
SportsPlus Bar remodel Building Designer and project consultant. Provided project design service and inspections of footing, foundation, metal framing, and metal works, reviewed cut sheets and shop drawings as owners rep.	2002 OBC A4 & M	Hc Design Group, LTD. 6235 Fay Court, Suite H Loveland, Ohio 45140 513-774-9099	11-4 to 6-5 (5 mts)
			20 months total
<b>TOTAL EXPERIENCE ON THIS PAGE (IN MONTHS):</b>			

**NOTE:** Only experience DIRECTLY related to buildings or structures within the scope of the groups regulated by the Ohio Building Codes shall be acceptable for credit for any certification, pursuant to rule 4101:1-1-01. **ONLY ELECTRICAL SAFETY INSPECTORS MAY LIST 1-, 2-, or 3-FAMILY EXPERIENCE.**



# Board of Building Standards

## APPLICATION FOR CERTIFICATION OF BUILDING DEPARTMENT PERSONNEL

Page 3 (You may make additional copies of this page if necessary.)

8. **EXPERIENCE (CONT.):** Refer to Experience Requirements Listed in 4101:1-1-01 OAC and 3783 ORC (DO NOT SUBSTITUTE WITH OTHER RESUMES). State the specific duties and type of work performed for each position listed. Give only information which relates directly to the information you provide. Provide letters from certified inspectors, employers, or contractors verifying your experience. Submit copies of any certificates, diplomas, or licenses received.

List Each Construction Project <u>AND</u> Specific Type of Work Performed	OBC Group	Name of Employer, Address, Telephone Number	Project Time: From_To_ (MM/DD/YY)
<p>Monte Vista Gardens 4-Unit Attached Condominiums Building Designer and project consultant Provided design services and project oversight to owner for 4-unit buildings. Inspections of soil, footing, foundations, retaining walls, slabs, framing and roof systems.</p>	<p>2000 IRC VB R3</p>	<p>Hc Design Group, LTD. 6235 Fay Court, Suite H Loveland, Ohio 45140 513-774-9099</p>	<p>1-1 to 12-4 (24 mts)</p>
<p>Monte Vista Gardens 10-Unit Accessible Apartments Building Designer and project consultant Provided design services and project oversight to owner for 10-unit buildings. Inspections of soil, footing, foundations, slabs, framing, roof systems, fire separation, cmu construction (elevators shaft), railing and stair assemblies, fabrication cut sheet review for stairs, roof and floor trusses and elevator and final review of project for compliance with ADA guild lines.</p>	<p>1998 OBBC</p>	<p>Hc Design Group, LTD. 6235 Fay Court, Suite H Loveland, Ohio 45140 513-774-9099</p>	<p>1-1 to 12-4 (24 mts)</p>
			48 months total
<b>TOTAL EXPERIENCE ON THIS PAGE (IN MONTHS):</b>			

**NOTE:** Only experience **DIRECTLY** related to buildings or structures within the scope of the groups regulated by the Ohio Building Codes shall be acceptable for credit for any certification, pursuant to rule 4101:1-1-01. **ONLY ELECTRICAL SAFETY INSPECTORS MAY LIST 1-, 2-, or 3-FAMILY EXPERIENCE.**



# Board of Building Standards

## APPLICATION FOR CERTIFICATION OF BUILDING DEPARTMENT PERSONNEL

Page 3 (You may make additional copies of this page if necessary.)

**8. EXPERIENCE (CONT.):** Refer to Experience Requirements Listed in 4101:1-1-01 OAC and 3783 ORC (DO NOT SUBSTITUTE WITH OTHER RESUMES). State the specific duties and type of work performed for each position listed. Give only information which relates directly to the information you provide. Provide letters from certified inspectors, employers, or contractors verifying your experience. Submit copies of any certificates, diplomas, or licenses received.

List Each Construction Project <u>AND</u> Specific Type of Work Performed	OBC Group	Name of Employer, Address, Telephone Number	Project Time: From_To_ (MM/DD/YY)
Monte Vista Gardens 4-Unit Detached Garage Building Designer and project consultant. Provided design services and project oversight to owner for 4-unit detached garages. Inspections of soil, footing, foundations, slabs, framing and roof systems.	1998 OBBC VB S-2	Hc Design Group, LTD. 6235 Fay Court, Suite H Loveland, Ohio 45140 513-774-9099	1-0 to 2-2 (10 mts)
Monte Vista Gardens 6-Unit Detached Garage Building Designer and project consultant. Provided design services and project oversight to owner for several different types of 6-unit detached garages and inspections of soil, footing, foundations, slabs, framing and roof systems.	1998 OBBC VB S-2	Hc Design Group, LTD. 6235 Fay Court, Suite H Loveland, Ohio 45140 513-774-9099	3-1 to 6-4 (12 mts)
Monte Vista Gardens 12-Unit Accessible Apartments Building Designer and project consultant Provided design services and project oversight to owner for 12-unit buildings. Inspections of soil, footing, foundations, slabs, framing, roof systems, fire separation, cmu construction (elevators shaft), railing and stair assemblies, fabrication cut sheet review for stairs, roof and floor trusses and elevator and final review of project for compliance with ADA guild lines.	1998 OBBC VB S-2	Hc Design Group, LTD. 6235 Fay Court, Suite H Loveland, Ohio 45140 513-774-9099	6-0 to 7-2 (15 mts)
			37 months total
<b>TOTAL EXPERIENCE ON THIS PAGE (IN MONTHS):</b>			

**NOTE:** Only experience **DIRECTLY** related to buildings or structures within the scope of the groups regulated by the Ohio Building Codes shall be acceptable for credit for any certification, pursuant to rule 4101:1-1-01. **ONLY ELECTRICAL SAFETY INSPECTORS MAY LIST 1-, 2-, or 3-FAMILY EXPERIENCE.**



# Board of Building Standards

## APPLICATION FOR CERTIFICATION OF BUILDING DEPARTMENT PERSONNEL

Page 3 (You may make additional copies of this page if necessary.)

8. EXPERIENCE (CONT.): Refer to Experience Requirements Listed in 4101:1-1-01 OAC and 3783 ORC (DO NOT SUBSTITUTE WITH OTHER RESUMES). State the specific duties and type of work performed for each position listed. Give only information which relates directly to the information you provide. Provide letters from certified inspectors, employers, or contractors verifying your experience. Submit copies of any certificates, diplomas, or licenses received.

List Each Construction Project AND Specific Type of Work Performed	OBC Group	Name of Employer, Address, Telephone Number	Project Time: From_To_ (MM/DD/YY)
<p>Monte Vista Gardens Community Building Building Designer and project consultant. Provided design services and project oversight to owner for Community Building which included: inspections of soil, footing, foundations, retaining walls, steel structure, timber trusses, framing, roof systems, fire separation, railing and stair assemblies, fabrication cut sheet review for stairs, roof, floor and timber trusses and final review of project for compliance with ADA guild lines (parking lot, sidewalks and pool).</p>	<p>1998 OBBC VB A-3</p>	<p>Hc Design Group, LTD. 6235 Fay Court, Suite H Loveland, Ohio 45140 513-774-9099</p>	<p>2-0 to 5-2 (20 mts)</p>
<p>Madison House Condominiums Milne Renovation Project designer, tradesmen and job superintendent. Provided project design, supervision and project coordination for owner. Filed permits, scheduled contractors, inspections, reviewed bids and provide framing and inside trim labor to owner.</p>	<p>2002 OBC VB R-2</p>	<p>Hc Design Group, LTD. 6235 Fay Court, Suite H Loveland, Ohio 45140 513-774-9099</p>	<p>10-2 to 4-4 (16 mts)</p>
			36 months total
<b>TOTAL EXPERIENCE ON THIS PAGE (IN MONTHS):</b>			

NOTE: Only experience DIRECTLY related to buildings or structures within the scope of the groups regulated by the Ohio Building Codes shall be acceptable for credit for any certification, pursuant to rule 4101:1-1-01. ONLY ELECTRICAL SAFETY INSPECTORS MAY LIST 1-, 2-, or 3-FAMILY EXPERIENCE.



# Board of Building Standards

## APPLICATION FOR CERTIFICATION OF BUILDING DEPARTMENT PERSONNEL

Page 3 (You may make additional copies of this page if necessary.)

**8. EXPERIENCE (CONT.):** Refer to Experience Requirements Listed in 4101:1-1-01 OAC and 3783 ORC (DO NOT SUBSTITUTE WITH OTHER RESUMES). State the specific duties and type of work performed for each position listed. Give only information which relates directly to the information you provide. Provide letters from certified inspectors, employers, or contractors verifying your experience. Submit copies of any certificates, diplomas, or licenses received.

List Each Construction Project <u>AND</u> Specific Type of Work Performed	OBC Group	Name of Employer, Address, Telephone Number	Project Time: From To (MM/DD/YY)
Welsh Excavation Office Building Project Designer and field consultant Provided design services and project oversight to owner for office building construction and parking lot which included: inspections of soil, footing, foundations, cmu wall construction, steel structure, framing and roof system. Provided cmu inspection every 3 lifts along with coordinating roof system bracing requirements with contractors.	2000 OBC O	Hc Design Group, LTD. 6235 Fay Court, Suite H Loveland, Ohio 45140 513-774-9099	2-0 to 5-2 (14 mts)
Saint Columban School Renovation Classroom remodel Project Designer and field consultant Provided design services and project oversight to owner for classroom and computer renovation.	2005 OBC 1A E	Hc Design Group, LTD. 6235 Fay Court, Suite H Loveland, Ohio 45140 513-774-9099	11-5 to 8-7 (6 mts)
Bloomin Garden Center Shelter Reconstruction Building Designer and field consultant Provided design services and project oversight to owner for shelter reconstruction which included review of piers, wood framing and cmu construction.	2007 OBC VB M1	Hc Design Group, LTD. 6235 Fay Court, Suite H Loveland, Ohio 45140 513-774-9099	2-8 to 2-9 (3 mts)
			23 months total
<b>TOTAL EXPERIENCE ON THIS PAGE (IN MONTHS):</b>			

**NOTE:** Only experience DIRECTLY related to buildings or structures within the scope of the groups regulated by the Ohio Building Codes shall be acceptable for credit for any certification, pursuant to rule 4101:1-1-01. **ONLY ELECTRICAL SAFETY INSPECTORS MAY LIST 1-, 2-, or 3-FAMILY EXPERIENCE.**





# Board of Building Standards

## APPLICATION FOR CERTIFICATION OF BUILDING DEPARTMENT PERSONNEL

Page 3 (You may make additional copies of this page if necessary.)

8. **EXPERIENCE (CONT.):** Refer to Experience Requirements Listed in 4101:1-1-01 OAC and 3783 ORC (DO NOT SUBSTITUTE WITH OTHER RESUMES). State the specific duties and type of work performed for each position listed. Give only information which relates directly to the information you provide. Provide letters from certified inspectors, employers, or contractors verifying your experience. Submit copies of any certificates, diplomas, or licenses received.

List Each Construction Project AND Specific Type of Work Performed	OBC Group	Name of Employer, Address, Telephone Number	Project Time: From To (MM/DD/YY)
Loveland Aerie of Eagle Interior and Exterior Renovation Project Designer and field consultant Provided design services and project inspections to Board President for remodel of bar and rest room areas. Provided inspections of parking lot, framing, worked with contractors, building officials and manufacturer of appliances to meet installation requirements along with designing new accessible rest rooms.	2005 OBC VB A-2	Hc Design Group, LTD. 6235 Fay Court, Suite H Loveland, Ohio 45140 513-774-9099	1-7 to 7-9 (10 mts)
Saint Margaret of York school and office Renovation Project Designer and field consultant Provided design services and project coordination to owner for day care and office remodel along with submitting for permits, coordination with contractor, mechanical engineers, alarm and sprinkler contractor.	2011 OBC 2B Mixed A-3 & B	Richard Ernst Architect 7351 Keller Road Sycamore Township, OH 45243 513-891-7102 / 891-3460 )	1-12 to current (on going)
Smith Addition Ramp addition Project designer, supervisor and contractor. Provided design and build services to owner. Applied for all permits, scheduled all inspections and coordinated all contractors.	2006 RCO VB SF	Hc Design Group, LTD. 6235 Fay Court, Suite H Loveland, Ohio 45140 513-774-9099	1-10 to 6-11 (8 mts)
			18 plus mts total
<b>TOTAL EXPERIENCE ON THIS PAGE (IN MONTHS):</b>			

**NOTE:** Only experience DIRECTLY related to buildings or structures within the scope of the groups regulated by the Ohio Building Codes shall be acceptable for credit for any certification, pursuant to rule 4101:1-1-01. **ONLY ELECTRICAL SAFETY INSPECTORS MAY LIST 1-, 2-, or 3-FAMILY EXPERIENCE.**



# Board of Building Standards

## APPLICATION FOR CERTIFICATION OF BUILDING DEPARTMENT PERSONNEL

Page 3 (You may make additional copies of this page if necessary.)

8. **EXPERIENCE (CONT.):** Refer to Experience Requirements Listed in 4101:1-1-01 OAC and 3783 ORC (DO NOT SUBSTITUTE WITH OTHER RESUMES). State the specific duties and type of work performed for each position listed. Give only information which relates directly to the information you provide. Provide letters from certified inspectors, employers, or contractors verifying your experience. Submit copies of any certificates, diplomas, or licenses received.

List Each Construction Project AND Specific Type of Work Performed	OBC Group	Name of Employer, Address, Telephone Number	Project Time: From_To_ (MM/DD/YY)
Ohio Valley Residential Services Faircrest Remodel Project design & field consultant Provided design services and project inspections to owner. Provided inspections as required of site, footing, foundations, retaining wall, framing, rated assemblies, NFPA 13 system, framing and finishes.	2000 OBC VB M	Hc Design Group, LTD. 6235 Fay Court, Suite H Loveland, Ohio 45140 513-774-9099	6-3 to 4-4 (10 mts)
Buckhead Homes Main office renovation Project Designer and field consultant Provided design services and project inspections to owner. Provided inspections as required of site, interior/exterior, wall framing, rated assemblies, accessible bathroom, finishes and parking lot.	1998 OBBC VA B	Hc Design Group, LTD. 6235 Fay Court, Suite H Loveland, Ohio 45140 513-774-9099	4-1 to 11-1 (5 mts)
Ryan Residence New accessible single family home Project Designer and field consultant Provided design services and project inspections to owner. Provided weekly inspections of site, footing, foundations, retaining walls, framing and mechanical. Worked with contractors and building officials and manufacturer to design and build a fully accessible home for owner and magistrate.	1999 RCO VB SF	Hc Design Group, LTD. 6235 Fay Court, Suite H Loveland, Ohio 45140 513-774-9099	7-3 to 12-6 (24 mts)
			39 months total
<b>TOTAL EXPERIENCE ON THIS PAGE (IN MONTHS):</b>			

**NOTE:** Only experience DIRECTLY related to buildings or structures within the scope of the groups regulated by the Ohio Building Codes shall be acceptable for credit for any certification, pursuant to rule 4101:1-1-01. **ONLY ELECTRICAL SAFETY INSPECTORS MAY LIST 1-, 2-, or 3-FAMILY EXPERIENCE.**



# Board of Building Standards

## APPLICATION FOR CERTIFICATION OF BUILDING DEPARTMENT PERSONNEL

Page 3 (You may make additional copies of this page if necessary.)

8. **EXPERIENCE (CONT.):** Refer to Experience Requirements Listed in 4101:1-1-01 OAC and 3783 ORC (DO NOT SUBSTITUTE WITH OTHER RESUMES). State the specific duties and type of work performed for each position listed. Give only information which relates directly to the information you provide. Provide letters from certified inspectors, employers, or contractors verifying your experience. Submit copies of any certificates, diplomas, or licenses received.

List Each Construction Project AND Specific Type of Work Performed	OBC Group	Name of Employer, Address, Telephone Number	Project Time: From To (MM/DD/YY)
Forest Park Housing Corporation New accessible single family home (Forest Park) Project Designer and field consultant Provided design services and project supervision to owner. Provided weekly/monthly inspections of site, footing, foundations, framing, insulation and mechanical. Reviewed all bids, cut sheets for all products. Worked with owners, contractors, builder, HUD officials and manufacturer to design and build a fully accessible home for owner.	2005 RCO VB SF	Hc Design Group, LTD. 6235 Fay Court, Suite H Loveland, Ohio 45140 513-774-9099	4-4 to 5-6 (14 mts)
Forest Park Housing Corporation New accessible single family home (Colerain) Project Designer and field consultant Provided design services and project supervision to owner. Provided weekly/monthly inspections of site, footing, foundations, framing, insulation and mechanical. Reviewed all bids, cut sheets for all products. Worked with owners, contractors, builder, HUD officials and manufacturer to design and build a fully accessible home for owner.	2005 RCO VB SF	Hc Design Group, LTD. 6235 Fay Court, Suite H Loveland, Ohio 45140 513-774-9099	4-4 to 5-6 (14 mts)
			28 months total
<b>TOTAL EXPERIENCE ON THIS PAGE (IN MONTHS):</b>			

**NOTE:** Only experience DIRECTLY related to buildings or structures within the scope of the groups regulated by the Ohio Building Codes shall be acceptable for credit for any certification, pursuant to rule 4101:1-1-01. **ONLY ELECTRICAL SAFETY INSPECTORS MAY LIST 1-, 2-, or 3-FAMILY EXPERIENCE.**



# Board of Building Standards

## APPLICATION FOR CERTIFICATION OF BUILDING DEPARTMENT PERSONNEL

Page 3 (You may make additional copies of this page if necessary.)

8. **EXPERIENCE (CONT.):** Refer to Experience Requirements Listed in 4101:1-1-01 OAC and 3783 ORC (DO NOT SUBSTITUTE WITH OTHER RESUMES). State the specific duties and type of work performed for each position listed. Give only information which relates directly to the information you provide. Provide letters from certified inspectors, employers, or contractors verifying your experience. Submit copies of any certificates, diplomas, or licenses received.

List Each Construction Project AND Specific Type of Work Performed	OBC Group	Name of Employer, Address, Telephone Number	Project Time: From_To_ (MM/DD/YY)
Moore Residence Project remodel Project Designer and field consultant Provided design services and project inspections to owner. Worked with owner to design standard roof system over flat roof and coordinated with structural engineer connection to existing cmu walls and provides inspections of connections and roof system.	1999 RCO VB SF	Hc Design Group, LTD. 6235 Fay Court, Suite H Loveland, Ohio 45140 513-774-9099	3-3 to 1-4 (12 mts)
Hahn Residence Room addition Project Designer and field consultant Provided design services and project inspections to owner. Provided inspections as required of footings, foundation, framing, insulation and mechanical and roof system.	2005 RCO VB SF	Hc Design Group, LTD. 6235 Fay Court, Suite H Loveland, Ohio 45140 513-774-9099	3-5 to 8-6 (15 mts)
Greenland Development Lot 7 Melogy Grove Building Designer	2005 RCO VB SF	Hc Design Group, LTD. 6235 Fay Court, Suite H Loveland, Ohio 45140 513-774-9099	2-5 to 3-6 (9 mts)
Gary Holland Homes Lot 112 Reserves of Provience Model Reserves of Provience Building Designer	" "		1-5 to 6-6 (11 mts)
Chrisman Homes Lot 15 Fairways of River's Glen Building Designer	" "		5-5 to 4-6 (9 mts)
			56 months total
<b>TOTAL EXPERIENCE ON THIS PAGE (IN MONTHS):</b>			

**NOTE:** Only experience DIRECTLY related to buildings or structures within the scope of the groups regulated by the Ohio Building Codes shall be acceptable for credit for any certification, pursuant to rule 4101:1-1-01. **ONLY ELECTRICAL SAFETY INSPECTORS MAY LIST 1-, 2-, or 3-FAMILY EXPERIENCE.**



# Board of Building Standards

## APPLICATION FOR CERTIFICATION OF BUILDING DEPARTMENT PERSONNEL

Page 3 (You may make additional copies of this page if necessary.)

8. EXPERIENCE (CONT.): Refer to Experience Requirements Listed in 4101:1-1-01 OAC and 3783 ORC (DO NOT SUBSTITUTE WITH OTHER RESUMES). State the specific duties and type of work performed for each position listed. Give only information which relates directly to the information you provide. Provide letters from certified inspectors, employers, or contractors verifying your experience. Submit copies of any certificates, diplomas, or licenses received.

List Each Construction Project AND Specific Type of Work Performed	OBC Group	Name of Employer, Address, Telephone Number	Project Time: From_To (MM/DD/YY)
O'Brien Remodel Room addition, kitchen & LR remodel Project Designer and field consultant Provided design services and project inspections to owner. Provided inspections as required of footings, foundation, framing and roof system.	2006 RCO VB SF	Hc Design Group, LTD. 6235 Fay Court, Suite H Loveland, Ohio 45140 513-774-9099	6-6 to 4-7 (10 mts)
Wallihan Residence 2nd story addition Project Designer and field consultant Provided design services and project inspections to owner. Provided inspections as required of framing, mechanicals and roof system.	2006 RCO VB SF	Hc Design Group, LTD. 6235 Fay Court, Suite H Loveland, Ohio 45140 513-774-9099	1-6 to 4-7 (5 mts)
Merrill Residence Single family home Building designer Provided design service	2005 RCO VB SF	Hc Design Group, LTD. 6235 Fay Court, Suite H Loveland, Ohio 45140 513-774-9099	9-5 to 12-5 (3 mts)
Gardner Residence Room addition, kitchen & bedroom remodel Owner Representative for BZA, Project Designer and field consultant Presented BZA presentation, upon approval provided design services and project inspections to owner. Provided inspections as required of footings, foundation, framing and roof system.	1999 RCO VB SF	Hc Design Group, LTD. 6235 Fay Court, Suite H Loveland, Ohio 45140 513-774-9099	11-3 to 4-5 (15 mts)
<b>TOTAL EXPERIENCE ON THIS PAGE (IN MONTHS):</b>			33 months total

NOTE: Only experience DIRECTLY related to buildings or structures within the scope of the groups regulated by the Ohio Building Codes shall be acceptable for credit for any certification, pursuant to rule 4101:1-1-01. ONLY ELECTRICAL SAFETY INSPECTORS MAY LIST 1-, 2-, or 3-FAMILY EXPERIENCE.



# Board of Building Standards

## APPLICATION FOR CERTIFICATION OF BUILDING DEPARTMENT PERSONNEL

Page 3 (You may make additional copies of this page if necessary.)

**8. EXPERIENCE (CONT.):** Refer to Experience Requirements Listed in 4101:1-1-01 OAC and 3783 ORC (DO NOT SUBSTITUTE WITH OTHER RESUMES). State the specific duties and type of work performed for each position listed. Give only information which relates directly to the information you provide. Provide letters from certified inspectors, employers, or contractors verifying your experience. Submit copies of any certificates, diplomas, or licenses received.

List Each Construction Project <u>AND</u> Specific Type of Work Performed	OBC Group	Name of Employer, Address, Telephone Number	Project Time: From_To_ (MM/DD/YY)
Chrisman Homes Wright remodel Project Designer and field consultant Provided design services and project inspections to owner. Provided inspections as required of demo and reconstruction of single family home. Inspections of framing, mechanicals and roof system.	2005 RCO VB SF	Hc Design Group, LTD. 6235 Fay Court, Suite H Loveland, Ohio 45140 513-774-9099	2-5 to 12-5 (7 mts)
Sabino Residence Deck addition Project designer Designer residential deck plan including structure.	2005 RCO VB SF	Hc Design Group, LTD. 6235 Fay Court, Suite H Loveland, Ohio 45140 513-774-9099	1-4 to 10-5 (3 mts)
West Residence Two story addition and remodel Building Designer Provided building addition CD's along with field consultant services. Inspected soil, footing, foundations, framing, insulation, floor and roof framing and cut sheets.	2005 RCO VB SF	Hc Design Group, LTD. 6235 Fay Court, Suite H Loveland, Ohio 45140 513-774-9099	1-5 to 12-6 (9 mts)
Hanna Residence Remodel and garage addition Project Designer and field consultant Provided design services and project inspections of demo, reconstruction of single family home which included: footings, foundation, framing and roof system.	2006 RCO VB SF	Hc Design Group, LTD. 6235 Fay Court, Suite H Loveland, Ohio 45140 513-774-9099	4-7 to 3-10 (21 mts)
<b>TOTAL EXPERIENCE ON THIS PAGE (IN MONTHS):</b>			40 months total

**NOTE:** Only experience **DIRECTLY** related to buildings or structures within the scope of the groups regulated by the Ohio Building Codes shall be acceptable for credit for any certification, pursuant to rule 4101:1-1-01. **ONLY ELECTRICAL SAFETY INSPECTORS MAY LIST 1-, 2-, or 3-FAMILY EXPERIENCE.**



# Board of Building Standards

## APPLICATION FOR CERTIFICATION OF BUILDING DEPARTMENT PERSONNEL

Page 3 (You may make additional copies of this page if necessary.)

8. **EXPERIENCE (CONT.):** Refer to Experience Requirements Listed in 4101:1-1-01 OAC and 3783 ORC (DO NOT SUBSTITUTE WITH OTHER RESUMES). State the specific duties and type of work performed for each position listed. Give only information which relates directly to the information you provide. Provide letters from certified inspectors, employers, or contractors verifying your experience. Submit copies of any certificates, diplomas, or licenses received.

List Each Construction Project AND Specific Type of Work Performed	OBC Group	Name of Employer, Address, Telephone Number	Project Time: From_To (MM/DD/YY)
Thiele Residence Room and deck addition and kitchen remodel Project Designer and Project Manager Provided design and project management services to owner. Permit and bond submittal, scheduling of contractors and contracting of framing, roofing, flashing, insulation and finish trim. Inspection of footing, foundation, crawl space, demo and roof system.	2006 RCO VB SF	Hc Design Group, LTD. 6235 Fay Court, Suite H Loveland, Ohio 45140 513-774-9099	2-7 to 6-8 (14 mts)
Sinnott Residence Remodel and room addition Project Designer, field consultant and contractor Provided design, field consultant and framing contractor services to owner. Provided weekly inspections of footing, foundation, framing, insulation roof system and finishes.	2006 RCO VB SF	Hc Design Group, LTD. 6235 Fay Court, Suite H Loveland, Ohio 45140 513-774-9099	10-5 to 8-7 (12 mts)
Bolan Residence LEED Certified single family home Building Designer	2006 RCO VB SF	Hc Design Group, LTD. 6235 Fay Court, Suite H Loveland, Ohio 45140 513-774-9099	1-8 to 6-11 (22 mts)
Watkins Residence Deck/screen room addition Project Designer	2009 RCO VB SF	Hc Design Group, LTD. 6235 Fay Court, Suite H Loveland, Ohio 45140 513-774-9099	4-11 to 12-11 (6 mts)
			54 total months
<b>TOTAL EXPERIENCE ON THIS PAGE (IN MONTHS):</b>			

**NOTE:** Only experience DIRECTLY related to buildings or structures within the scope of the groups regulated by the Ohio Building Codes shall be acceptable for credit for any certification, pursuant to rule 4101:1-1-01. **ONLY ELECTRICAL SAFETY INSPECTORS MAY LIST 1-, 2-, or 3-FAMILY EXPERIENCE.**



# Board of Building Standards

## APPLICATION FOR CERTIFICATION OF BUILDING DEPARTMENT PERSONNEL

Page 3 (You may make additional copies of this page if necessary.)

8. **EXPERIENCE (CONT.):** Refer to Experience Requirements Listed in 4101:1-1-01 OAC and 3783 ORC (DO NOT SUBSTITUTE WITH OTHER RESUMES). State the specific duties and type of work performed for each position listed. Give only information which relates directly to the information you provide. Provide letters from certified inspectors, employers, or contractors verifying your experience. Submit copies of any certificates, diplomas, or licenses received.

List Each Construction Project AND Specific Type of Work Performed	OBC Group	Name of Employer, Address, Telephone Number	Project Time: From To (MM/DD/YY)
Timerding Residence Room addition and kitchen remodel Project Designer and field consultant Provided design and field consultant services to owner. Owner representative for BZA and VA process. Will provide inspection as required during construction which will include: footing, foundation, slab, framing, plumbing, electrical and HVAC.	2009 RCO VB SF	Hc Design Group, LTD. 6235 Fay Court, Suite H Loveland, Ohio 45140 513-774-9099	9-11 to current
Ellis Residence Room addition and kitchen remodel Project Designer	2006 RCO VB SF	Hc Design Group, LTD. 6235 Fay Court, Suite H Loveland, Ohio 45140 513-774-9099	7-8 to 4-9 (6 mts)
Brockman Residence Porch addition and roof remodel Project Designer and field consultant Provided design and field consultant services to owner. Provide inspection as required during construction which will include: footing, foundation, slab, framing and flashing.	2006 RCO VB SF	Hc Design Group, LTD. 6235 Fay Court, Suite H Loveland, Ohio 45140 513-774-9099	11-9 to 10-10 (13 mts)
Lawry Residence Two story room addition Project Designer and field consultant Provided design and field consultant services to owner.	2006 RCO VB SF	Hc Design Group, LTD. 6235 Fay Court, Suite H Loveland, Ohio 45140 513-774-9099	9-10 to 11-3 (8 mts)
			27+ months total
<b>TOTAL EXPERIENCE ON THIS PAGE (IN MONTHS):</b>			

**NOTE:** Only experience DIRECTLY related to buildings or structures within the scope of the groups regulated by the Ohio Building Codes shall be acceptable for credit for any certification, pursuant to rule 4101:1-1-01. **ONLY ELECTRICAL SAFETY INSPECTORS MAY LIST 1-, 2-, or 3-FAMILY EXPERIENCE.**





# Board of Building Standards

## APPLICATION FOR CERTIFICATION OF BUILDING DEPARTMENT PERSONNEL

Page 3 (You may make additional copies of this page if necessary.)

8. **EXPERIENCE (CONT.):** Refer to Experience Requirements Listed in 4101:1-1-01 OAC and 3783 ORC (DO NOT SUBSTITUTE WITH OTHER RESUMES). State the specific duties and type of work performed for each position listed. Give only information which relates directly to the information you provide. Provide letters from certified inspectors, employers, or contractors verifying your experience. Submit copies of any certificates, diplomas, or licenses received.

List Each Construction Project AND Specific Type of Work Performed	OBC Group	Name of Employer, Address, Telephone Number	Project Time: From_To_ (MM/DD/YY)
Premier Food Service New office and warehouse Project Designer, field consultant and owners rep. Provided design, appeal and field consultant services to owner. Coordinated multidiscipline group which included site, structural and mechanical engineers and manufacturers. Provide inspection as required during construction of soil, footing, foundation, slab, steel structure and framing.	2003 OBC VB	Hc Design Group, LTD. 6235 Fay Court, Suite H Loveland, Ohio 45140 513-774-9099	2-3 to 8-5 (20 mts)
Steckler Properties Insurance remodel Project Designer, Manager and contractor Provided design and build services to owner. Applied for all permits, scheduled all inspections along with performing contractor duties and scheduling contractor.	2006 OBC VB O	Hc Design Group, LTD. 6235 Fay Court, Suite H Loveland, Ohio 45140 513-774-9099	5-7 to 3-8 (10 mts)
			30 months total
<b>TOTAL EXPERIENCE ON THIS PAGE (IN MONTHS):</b>			

**NOTE:** Only experience DIRECTLY related to buildings or structures within the scope of the groups regulated by the Ohio Building Codes shall be acceptable for credit for any certification, pursuant to rule 4101:1-1-01. **ONLY ELECTRICAL SAFETY INSPECTORS MAY LIST 1-, 2-, or 3-FAMILY EXPERIENCE.**

**Board of Building Standards**

Application for Interim Certification, Building Department Personnel

Holbert, Jr.  
Last Name

Harry L.  
First Name

4776  
BBS Certification ID

List Each Construction Project <u>AND</u> Specific Type of Work Performed	Name of Employer, Contact, Address, Telephone Number	Project Time: From _ To _ (MM/YY)
Riverbend Sports Plex 199 Winding River Blvd. Maineville, Ohio 45039 Building Design	Richard Ernst Architect 7351 Keller Road Sycamore township 45243 513-891-7102	04/18 to 7/19
Trailside Cafe 123 Railroad Lane Cleveland Oh. 45140 Building Design	Richard Ernst Architect 7351 Keller Road Sycamore township 45243 513-891-7102	01/18 to 3/20
Total Experience on This Page (In Months):		41 months

Halbert, Jr  
Last Name

Harry L.  
First Name

9776  
BBS Certification ID

**SECTION 8: PERSONAL HISTORY**

- 1. Have you ever been convicted of any felony, or any crime involving moral turpitude?  Yes  No  
If you answered "Yes" please explain below:
- 2. Have you served in the U.S. armed services? (If No, skip question 3)  Yes  No
- 3. If YES, were you discharged under honorable conditions?  Yes  No

If you answered "No" please explain below:

**SECTION 9: CERTIFICATION**

I certify the information contained in this application is true and complete, and I understand that providing false information may be grounds for not granting certification or for immediate termination of certification at any point in the future, if granted. I authorize the investigation of all statements contained herein and release all parties from all liability for any damage that may result from furnishing the same to Ohio Board of Building Standards. Falsification is a violation of section 2921.13 of the Ohio Revised Code and is punishable as a misdemeanor of the first degree.

Signature of Applicant: Harry L. Halbert Jr

Subscribed and duly sworn before me according to law, by the above named applicant this day 13th of September in the year 2022 at Cleves, County of Wilford and State of Ohio.

Notary Public: C. Arlene Schwan



**C. ARLENE SCHWAN**  
Notary Public, State of Ohio  
My Commission Expires  
March 14, 2027

## **•Professional Summary:**

An ethical and apolitical decision-maker with a record of professional accomplishments, and a passion for public service. Confident, visionary leader who is committed to; continuous departmental improvements, great customer service and is a proactive and imaginative problem solver with a “can-do-attitude”, who thinks beyond the constraints of traditional government or conventional business practices. One who has established and maintains positive and productive relationships with people at all levels including; residents, community groups, media personnel, local, State, and Federal agencies; and private sector partners. Committed to ensuring quality of life and high economic development standards, while maintaining integrity, diversity, and fairness.

## **•Current Professional Experience Overview:**

### **Planning and Zoning Director**

**Goshen Township; Goshen, OH**

2019 - Present

- Leader of the day to day operations and budget for Planning (Short and Long-Range), Zoning, Economic Development, and Downtown Revitalization
- Broad background in Urban Planning, Community and Economic Development Principles
- Recruitment, motivation, evaluation and leader of Planning, Zoning and Property Maintenance staff, implementation of office standards, prioritizing and assigning of tasks and personnel training
- Key member of Township’s Management, Logo, Land Use, Strategic Plan and Goshen Recovery teams
- Oversee the interpretation, execution, and updating of Zoning Resolution, Sign, Site, Subdivision and Landscape Plan review, Land Use Maps, Capital Improvements, Grants, and Property Maintenance
- Provide sound planning principles and zoning analysis for zoning compliance approval, while providing guidance to applicants when appeals, variances or zone changes are necessary
- Liaison to Citizen Groups, Township’s Architectural Review Board, Board of Zoning Appeals, Property Maintenance Board, Zoning Commission, Board of Township Trustees and County Prosecutor’s Office, while also serving as Project Liaison between applicant(s), County, Federal and State agencies
- Provide continuous support to; Township Residents, Board of Trustees, and Township Administrator and assist with daily Township operations, including support of: Fire, Maintenance, Police, Parks and Recreation Department
- Work with all stakeholders for effective use and development of property within the Township
- Conduct building and property maintenance inspections and work with banks, contractors, County, property owners, real estate agents, and tenants, to improve conditions of properties in violation

## **•Work Chronology:**

### **Planning and Zoning Administrator**

**Sycamore Township, Cincinnati, OH**

2008 – 2019

### **Project Manager and Senior Designer**

**HC Design Group, LTD., Loveland, OH**

1990 – 2008

### **Project Manager, Sales and Senior Designer**

**WHC, Colerain and Mason, OH**

1987 – 2003

## **•Education:**

**Xavier University, Bachelor of Liberal Arts, Concentration in Organizational Leadership**

**University of Cincinnati, Construction Management and Engineering Majors**

**Cincinnati State Technical and Community College, Civil Engineering Technology:**

- Degree of Architecture
- Degree of Construction Management
- Degree of Surveying

**•Professional Memberships:**

- American Planning Association
- American Planning Association, Ohio Chapter
- International Code Council
- LEAD Clermont County
- Ohio Building Official Association
- Ohio Township Association
- Ohio Township Association, Zoning Inspectors Group
- Professional Land Surveyors of Ohio
- Southwestern Ohio Building Official Association

**•Certifications and Code Knowledge:**

- State of Ohio Building Inspector, and Residential Building Official-Int.
- O.S.H.A. 10 hour Certification
- A.D.A Guidelines, Hamilton County Building Code, I.P.M.C, O.B.C, Residential Code of Ohio, Miami, Goshen, and Sycamore Township Zoning Resolutions
- Bonded in the State of Ohio
- Class D, State of Ohio driver license (Organ Donor)
- CPR, AED and First Aid Certifications

**•Software Proficiencies:**

- Adobe Acrobat, Microsoft Office Suite and Windows
- ESRI GIS for Butler, Clermont, Hamilton and Warren Counties
- Gen7, Egov, Permits Plus and Acela Permitting Software
- AutoCAD, Micro Station, Softplan, StruCalc and Vituvius

**•Community Involvement:**

- Habitat for Humanity
- Board of Director, Suburban Communities Energy Special Improvement District
- Consultant, St. Andrew Church/design improvements and fundraisers
- CYO Football Coach: St. Andrew St. Elizabeth Ann Seton
- Youth and High School Ice Hockey Coach: Cincinnati Amateur Hockey Association, Indian Hill Winter Club and Cincinnati Swords
- Moeller High School athletics booster and volunteer
- Ohio Disaster Response Team
- Unmet Needs Committee-EMA
- Xavier Parent Family Advisory Board
- APA Adopt a Class

**File Attachments for Item:**

P-6 Losekamp, Kenneth ESI

Certification ID# 8915

Current certifications- BI, RBI

Staff notes-Unclear whether he performed the work listed: request for clarification sent 9/13

ESIAC Recommendations: Need additional information on work performed.

Committee recommendation:

**SECTION 1: CHECK INTERIM CERTIFICATION(S) BEING REQUESTED**

<input type="checkbox"/> Building Official	<input type="checkbox"/> Master Plans Examiner	<input type="checkbox"/> Building Inspector	<input checked="" type="checkbox"/> Electrical Safety Inspector	<input type="checkbox"/> Fire Protection Inspector
<input type="checkbox"/> Building Plans Examiner	<input type="checkbox"/> Plumbing Plans Examiner	<input type="checkbox"/> Mechanical Plans Examiner	<input type="checkbox"/> Electrical Plans Examiner	<input type="checkbox"/> Fire Protection Plans Examiner
	<input type="checkbox"/> Plumbing Inspector	<input type="checkbox"/> Mechanical Inspector	<input type="checkbox"/> Non-Residential Industrial Unit Inspector	

**SECTION 2: LIST ANY OHIO LICENSE, CERTIFICATE, OR REGISTRATION HELD**

(Mark "T" If Trainee)

Description		Certificate Number	Date Received
Architectural Registration			
P.E. Registration			
Res	Non-Res		
<input type="checkbox"/>	<input checked="" type="checkbox"/>	8915	8/31/2022
<input type="checkbox"/>	<input type="checkbox"/>		
<input type="checkbox"/>	<input type="checkbox"/>		
<input type="checkbox"/>	<input type="checkbox"/>		
Building Official Certification			
Plans Examiner Certification			
Building Inspector Certification			
Mechanical Inspector Certification			
Building Plans Examiner Certification			
Mechanical Plans Examiner Certification			
Fire Protection Plans Examiner Certification			
Electrical Plans Examiner Certification			
Plumbing Plans Examiner Certification			
Fire Protection Inspector Certification			
Electrical Safety Inspector Certification			
Plumbing Inspector Certification			
Fire Safety Inspector Certification			
Fire Protection System Designer Certification			
Medical Gas Piping Inspector Certification			

**SECTION 3: EMPLOYMENT/EDUCATION**

Formal Education	Date Graduated
Purcell High School	1974
Related Vocational or Technical Training	Years' Experience
U.S. Military construction experience (MOS or other designation):	Years' Experience
Place of Employment:	Years' Employed
Losekamp Paradise of Homes, President	25 years
Saveway Office Equipment, Owner	25 Years

**SECTION 4: APPLICANTS REQUESTING MEDICAL GAS INSPECTOR CERTIFICATION**

*Attach proof of certification by an ASSE recognized third-party certifier in accordance with ASSE standard 6020.*

**SECTION 5: OBC BUILDING INSPECTION EXPERIENCE PERFORMED FOR A BBS CERTIFIED BUILDING DEPARTMENT**

BBS Certified Building Department	BBS Certified Position/Title	Duties	Date of Service, Length of Time (MM/DD/YY)



LOSEKAMP

KENNETH

*Last Name*

*First Name*

*BBS Certification ID*

**SECTION 6: ELECTRICAL SAFETY INSPECTOR (ESI) - SPECIFIC EXPERIENCE QUALIFICATIONS**

Applicants for Electrical Safety Inspector Only Must Complete This Item

Section 3783 of the Ohio Revised Code specifies that an applicant for a Certificate of Competency as an Electrical Safety Inspector must meet one of the following to qualify to take required examination. Please check the qualification that applies:

1.  Have been a journeyman electrician or equivalent for four years, two of which were as an electrician foreman, and have had two years' experience as a building department electrical inspector trainee;
2.  Have been a journeyman electrician or equivalent for four years and have had three years' experience as a building department electrical inspector trainee;
3.  Have had for four years' experience as a building department electrical inspector trainee;
4.  Have been a journeyman electrician or equivalent for six years;
5.  Am a graduate electrical engineer and registered in the State of Ohio. Registration number: \_\_\_\_\_
6.  Applicant authorizes all testing organizations including ICC to provide test results to the BBS.

**SECTION 7: EXPERIENCE (DO NOT SUBSTITUTE WITH OTHER RESUMES).**

Refer to Experience Requirements Listed in O.A.C. 4101:7-3-01 and O.R.C. 3783

Below, list the specific projects you worked on, and the specific work you performed, your typical duties for each project, and dates of this work. You **must** demonstrate that you have the required number of months (years) of actual, practical experience for the certification requested (see matrix).

Provide letters from certified inspectors, employers, or contractors verifying your experience. Submit copies of any certificates, diplomas, or licenses. Remove all personal information.

**SECTION 7 CONT.: EXPERIENCE**

List Each Construction Project <u>AND</u> Specific Type of Work Performed	Name of Employer, Contact, Address, Telephone Number	Project Time: From _ To _ (MM/YY)
<p><i>Example:</i> Children's Hospital, Toledo Structural steel work on addition</p> <p>Clermont County Board of MRDD Multiple contracts for ADA adaptation of clients including electrical adaptation.</p> <p>Wired all bathrooms and multipurpose rooms, ran circuits, outlets and lights</p>	<p>Homer Steel and Trade 125 Anytown Street My City, OH, 45454 (419)555-1212</p> <p>Losekamp Paradise of Homes 2040 Grandview Ln Bataiva, Ohio 45103 513-404-4066</p>	<p>July 2013-May 2014 (10 months)</p>
<p><b>Total Experience on This Page (In Months):</b></p>		<p>24 months</p>

**Board of Building Standards**  
**Losekamp**

Application for Interim Certification, Building Department Personnel

**Kenneth**

Last Name

First Name

BBS Certification ID

List Each Construction Project <u>AND</u> Specific Type of Work Performed	Name of Employer, Contact, Address, Telephone Number	Project Time: From_ To _ (MM/YY)
Moore Racing: Framing, Electric installed new trans, new meters, panels, breakers, wiring and circuits	All work was completed under Losekamp Paradise of Homes 2040 Grandview Ln Bataiva, Ohio 45103 513-404-4066	2016-2020
----- Eastside Fitness Framing, Electric, Addition new panel, breakers, commercial building rewired outlets		2014 - 2015
----- Cobra Club Camp Grounds Foundation, electric, bobcat work ran underground wiring, panel, circuits, outlets		2016
----- St Ann's Catholic Church, Williamsburg Framing, Roofing, Siding, Foundation, Electric - ran multiple circuits		2010 - 2013
----- Residential Concepts Framing, Electric, Roofing, Siding Ran 6 underground main services, all new panels, circuits, wiring, outlets for group homes and store meeters		2003 - 2007, 2010 - 2012
----- Holy Trinity, Batavia Framing, Electric ran new circuits		2008
----- Kramer Myers Insurance Multiple locations Framing, Roofing, Electric ran new service and panels, wiring and circuits		2007 - 2009
----- Clermont County Social Security Building. New construction, framing, electric - ran interior circuits		1999-2001
----- Bakers Pub installed wiring, circuits, outlets and lights		1999-2000
----- Polaris, framing, electric - ran panel wiring, ran multiple circuits		1998 - 1999
----- Paw Print Animal Hospital Siding, Framing, Electric multiple circuits		1998 - 1999
----- Fairfax Pony Keg and Bar installed circuits and wiring, outlets and lights		1998-1999
----- Saveway Office Equipment Framing, Electric - new service overhead, panel, meters, breakers, wiring, circuits,		1994-1997
----- Amerigan Legion post 72, Framing, electric, new meter, panel, breakers, wiring, and circuits	1982 -1984	
<b>Total Experience on This Page (In Months):</b>		

**Board of Building Standards  
Losekamp**

Application for Interim Certification, Building Department Personnel

**Kenneth**

Last Name

First Name

BBS Certification ID

**SECTION 4: OBC/RCO BUILDING INSPECTION EXPERIENCE PERFORMED FOR A BBS CERTIFIED BUILDING DEPARTMENT**

BBS Certified Building Department	BBS Certified Position/Title	Duties	Date of Service, Length of Time (MM/DD/YY)

**SECTION 5: EXPERIENCE (DO NOT SUBSTITUTE WITH OTHER RESUMES).**

Refer to Experience Requirements Listed in O.A.C. 4101:7-3-01 and O.R.C. 3783

Below, list the specific projects you worked on, and the specific work you performed, your typical duties for each project, and dates of this work. You **must** demonstrate that you have the required number of months (years) of actual, practical experience for the certification requested (see matrix).

Provide letters from certified inspectors, employers, or contractors verifying your experience. Submit copies of any certificates, diplomas, or licenses. Remove all personal information.

List Each Construction Project <u>AND</u> Specific Type of Work Performed	Name of Employer, Contact, Address, Telephone Number	Project Time: From_ To _ (MM/YY)
<p><i>Example:</i>                      Children's Hospital, Toledo                      Structural steel work on addition                      2040 Grandview Ln, Batavia Ohio                      New Build - complete framing - all exterior walls, interior walls, setting trusses, setting deck posts, framing deck, finishing deck and all interior trim. electric - transformer and meter base, panels, Circuits, lighting, wiring, outlets.</p>	<p>Homer Steel and Trade                      125 Anytown Street                      My City, OH, 45454                      (419)555-1212                      Losekamp Paradise of Homes                      2040 Grandview Ln                      Bataiva, Ohio 45103                      513-404-4066</p>	<p>July 2013-May 2014                      (10 months)</p>
<b>Total Experience on This Page (In Months):</b>		<b>1989-90 12 mo</b>

# Board of Building Standards Losekamp

Last Name

Application for Interim Certification, Building Department Personnel

# Kenneth

First Name

BBS Certification ID

## SECTION 5 CONT.: EXPERIENCE

List Each Construction Project <u>AND</u> Specific Type of Work Performed	Name of Employer, Contact, Address, Telephone Number	Project Time: From_ To _ (MM/YY)
2040 Grandview Ln, Batavia, Ohio all steel structure, framing, electric panel, circuits, lighting, outlets,	All work completed under Losekamp Paradise of Homes 2040 Grandview Ln Bataiva, Ohio 45103 513-404-4066	1997
2030 Grandview Ln, Batavia, Ohio all steel structure, framing, electric panel, circuits, lighting, outlets		1997
51 Indian Dr., Lake Waynoka, Ohio New Build - complete framing - all exterior walls, interior walls, setting trusses, setting deck posts, framing deck, finishing deck and all interior trim. electric - transformer and meter base, panels, Circuits, lighting, wiring, outlets.		1998
36 Wagon Wheel, Lake Waynoka, Ohio New Build - complete framing - all exterior walls, interior walls, setting trusses, setting deck posts, framing deck, finishing deck and all interior trim. electric - transformer and meter base, panels, Circuits, lighting, wiring, outlets.		2000
53 Indian Dr, Lake Waynoka, Ohio -New Build - complete framing - all exterior walls, interior walls, setting trusses, setting deck posts, framing deck, finishing deck and all interior trim. electric - transformer and meter base, panels, Circuits, lighting, wiring, outlets.		2000
164 Navajo Drive, Lake Waynoka, Ohio - Addiiton - complete framing, electric -Circuits, lighting, wiring, outlets.		2001
4299 Milhaven Dr., Batavia, Ohio New Build - complete framing - all exterior walls, interior walls, setting trusses, setting deck posts, framing deck, finishing deck and all interior trim. electric - meter base, panels, Circuits, lighting, wiring, outlets.		2001
5225 St. Rt 132, Batavia, Ohio - complete renovation interior walls all interior trim. electric - , panels, Circuits, lighting, wiring, outlets.		2001
32 Wagon Wheel, Lake Waynoka, Ohio, Complete Remodel - complete framing - all exterior walls, interior walls setting deck posts, framing deck, finishing deck and all interior trim. electric - panels, Circuits, lighting, wiring, outlets.		2002
3725 Mt. Carnel Rd., Cincinnati Ohio, Addition - complete framing - all exterior walls, interior walls, setting trusses, setting deck posts, framing deck, finishing deck and all interior trim. electric - panels, Circuits, lighting, wiring, outlets.		2003
<b>Total Experience on This Page (In Months):</b>		

List Each Construction Project AND Specific Type of Work Performed	Name of Employer, Contact, Address, Telephone	Project Time: From_ To _ (MM/YY)
48 Indian Dr. Lake Waynoka, Ohio New Build - complete framing - all exterior walls, interior walls, setting trusses, setting deck posts, framing deck, finishing deck and all interior trim. electric - transformer and meter base, panels, Circuits, lighting, wiring, outlets.	Losekamp Paradise of Homes 2040 Grandview Ln Bataiva, Ohio 45103 513-404-4066	2003
4 Indian Dr. Lake Waynoka, Ohio New Build - complete framing - all exterior walls, interior walls, setting trusses, setting deck posts, framing deck, finishing deck and all interior trim. electric - transformer and meter base, panels, Circuits, lighting, wiring, outlets.	Losekamp Paradise of Homes 2040 Grandview Ln Bataiva, Ohio 45103 513-404-4066	2004
7 Creek Cove, Lake Waynoka, Ohio New Build - complete framing - all exterior walls, interior walls, setting trusses, setting deck posts, framing deck, finishing deck and all interior trim. electric - transformer and meter base, panels, Circuits, lighting, wiring, outlets.	Losekamp Paradise of Homes 2040 Grandview Ln Bataiva, Ohio 45103 513-404-4066	2004
2 Coyote Cove, Lake Waynoka, Ohio New Build - complete framing - all exterior walls, interior walls, setting trusses, setting deck posts, framing deck, finishing deck and all interior trim. electric - transformer and meter base, panels, Circuits, lighting, wiring, outlets.	Losekamp Paradise of Homes 2040 Grandview Ln Bataiva, Ohio 45103 513-404-4066	2004
3118 Lucas Dr, Hammersville, Ohio - New Build - complete framing - all exterior walls, interior walls, setting trusses, setting deck posts, framing deck, finishing deck and all interior trim. electric - transformer and meter base, panels, Circuits, lighting, wiring, outlets.	Losekamp Paradise of Homes 2040 Grandview Ln Bataiva, Ohio 45103 513-404-4066	2005
5311 St. Rt. 132, Batavia, Ohio - Addition - complete framing - all exterior walls, interior walls, setting trusses, and all interior trim. electric - Circuits, lighting, wiring, outlets.	Losekamp Paradise of Homes 2040 Grandview Ln Bataiva, Ohio 45103 513-404-4066	2005
14 Long Navajo Cove, Lake Waynoka, Ohio New Build - complete framing - all exterior walls, interior walls, setting trusses, setting deck posts, framing deck, finishing deck and all interior trim. electric - transformer and meter base, panels, Circuits, lighting, wiring, outlets.	Losekamp Paradise of Homes 2040 Grandview Ln Bataiva, Ohio 45103 513-404-4066	2005

8629 Coran Dr. Addition - complete framing - all exterior walls, interior walls, setting trusses, all interior trim. electric - meter base, panels, Circuits, lighting, wiring, outlets.	Losekamp Paradise of Homes 2040 Grandview Ln Bataiva, Ohio 45103 513-404-4066	2005
440 Waynoka Dr., Lake Waynoka, Ohio New Build - complete framing - all exterior walls, interior walls, setting trusses, setting deck posts, framing deck, finishing deck and all interior trim. electric - transformer and meter base, panels, Circuits, lighting, wiring, outlets.	Losekamp Paradise of Homes 2040 Grandview Ln Bataiva, Ohio 45103 513-404-4066	2006
164 Navajo Dr., Lake Waynoka, Ohio Addition - complete framing - all exterior walls, interior walls, setting trusses, all interior trim. electric - panels, Circuits, lighting, wiring, outlets.	Losekamp Paradise of Homes 2040 Grandview Ln Bataiva, Ohio 45103 513-404-4066	2006
6136 St. Rt 132, Batavia New Build - complete framing - all exterior walls, interior walls, setting trusses, setting deck posts, framing deck, finishing deck and all interior trim. electric - meter base, panels, Circuits, lighting, wiring, outlets.	Losekamp Paradise of Homes 2040 Grandview Ln Bataiva, Ohio 45103 513-404-4066	2006
1675 Misty Hollow Ct., Batavia Ohio New Build - complete framing - all exterior walls, interior walls, setting trusses, setting deck posts, framing deck, finishing deck and all interior trim. electric - meter base, panels, Circuits, lighting, wiring, outlets.	Losekamp Paradise of Homes 2040 Grandview Ln Bataiva, Ohio 45103 513-404-4066	2007
344 Waynoka Dr. Lake Waynoka, Ohio New Build - complete framing - all exterior walls, interior walls, setting trusses, setting deck posts, framing deck, finishing deck and all interior trim. electric - transformer and meter base, panels, Circuits, lighting, wiring, outlets.	Losekamp Paradise of Homes 2040 Grandview Ln Bataiva, Ohio 45103 513-404-4066	2007
51 Indian Dr. Lake Waynoka, Ohio adding basement apartment - interior walls, and all interior trim. electric - Circuits, lighting, wiring, outlets.	Losekamp Paradise of Homes 2040 Grandview Ln Bataiva, Ohio 45103 513-404-4066	2008
5 Apache Cove, Lake Waynoka, Ohio New Build - complete framing - all exterior walls, interior walls, setting trusses, setting deck posts, framing deck, finishing deck and all interior trim. electric - transformer and meter base, panels, Circuits, lighting, wiring, outlets.	Losekamp Paradise of Homes 2040 Grandview Ln Bataiva, Ohio 45103 513-404-4066	2008
20 Arrow Cover, Lake Waynoka, Ohio New Build - complete framing - all exterior walls, interior walls, setting trusses, setting deck posts, framing deck, finishing deck and all interior trim. electric - transformer and	Losekamp Paradise of Homes 2040 Grandview Ln Bataiva, Ohio 45103 513-404-4066	2008

meter base, panels, Circuits, lighting, wiring, outlets.		
276 Frances Rd, Blanchester Ohio - Addition complete framing - all exterior walls, interior walls, setting trusses, and all interior trim. electric - panels, Circuits, lighting, wiring, outlets.	Losekamp Paradise of Homes 2040 Grandview Ln Bataiva, Ohio 45103 513-404-4066	2013
499 South Broadway – Complete Renovation- complete framing - all exterior walls, interior walls, setting trusses, setting deck posts, framing deck, finishing deck and all interior trim. electric - panels, Circuits, lighting, wiring, outlets.	Losekamp Paradise of Homes 2040 Grandview Ln Bataiva, Ohio 45103 513-404-4066	2013
499 South Broadway – 4 car garage - all exterior walls, interior walls, setting trusses, electric - panels, Circuits, lighting, wiring, outlets.	Losekamp Paradise of Homes 2040 Grandview Ln Bataiva, Ohio 45103 513-404-4066	2014
2020 Countryside Dr. Batavia, Ohio - Addition complete framing - all exterior walls, interior walls, setting trusses, and all interior trim. setting deck posts, framing deck, finishing deck, electric - panels, Circuits, lighting, wiring, outlets.	Losekamp Paradise of Homes 2040 Grandview Ln Bataiva, Ohio 45103 513-404-4066	2014
4789 Pewter, Cincinnati, Ohio – Remodel - interior walls, and all interior trim. electric - Circuits, lighting, wiring, outlets.	Losekamp Paradise of Homes 2040 Grandview Ln Bataiva, Ohio 45103 513-404-4066	2014
1245 Wayside Place, Cincinnati, Ohio – Finish Basement - interior walls, and all interior trim. electric - Circuits, lighting, wiring, outlets.	Losekamp Paradise of Homes 2040 Grandview Ln Bataiva, Ohio 45103 513-404-4066	2016
4830 Teal Ln, Milford, Ohio Built new barn – framing, panel, lighting outlets	Losekamp Paradise of Homes 2040 Grandview Ln Bataiva, Ohio 45103 513-404-4066	2020
3590 Weaver Rd, Batavia Ohio New Service Panel	Personal	2021

Losekamp

Kenneth

Last Name

First Name

BBS Certification ID

SECTION 8: PERSONAL HISTORY

1. Have you ever been convicted of any felony, or any crime involving moral turpitude?

Yes  No

If you answered "Yes" please explain below:

2. Have you served in the U.S. armed services? (If No, skip question 3)

Yes  No

3. If YES, were you discharged under honorable conditions?

Yes  No

If you answered "No" please explain below:

Empty table for explanation of "No" answers.

SECTION 9: CERTIFICATION

I certify the information contained in this application is true and complete, and I understand that providing false information may be grounds for not granting certification or for immediate termination of certification at any point in the future, if granted. I authorize the investigation of all statements contained herein and release all parties from all liability for any damage that may result from furnishing the same to Ohio Board of Building Standards. Falsification is a violation of section 2921.13 of the Ohio Revised Code and is punishable as a misdemeanor of the first degree.

Signature of Applicant:

Kenneth A. Losekamp

Subscribed and duly sworn before me according to law, by the above named applicant this

day 7 of September in the year 2022 at Cincinnati, County of Hamilton and State of Ohio

Notary Public:

Melissa K. Losekamp

My Commission Expires April 15, 2023





**File Attachments for Item:**

P-7 Prescott, Aaron - ESI Trainee, Alternative Trainee Program

Cert ID: 8933

Current Certifications: None

Staff Notes: Alternative trainee plan tailored to meet applicant's needs to be successful as an ESI. Recommend approval.

Committee Recommendations:

Prescott  
Last Name

Aaron  
First Name

\_\_\_\_\_  
BBS Certification ID

**SECTION 1: CHECK TRAINEE CERTIFICATION(S) BEING REQUESTED**

<input type="checkbox"/> Master Plans Examiner	<input type="checkbox"/> Building Plans Examiner	<input type="checkbox"/> Electrical Plans Examiner	<input type="checkbox"/> Fire Protection Plans Examiner	<input type="checkbox"/> Mechanical Plans Examiner
<input type="checkbox"/> Plumbing Plans Examiner	<input type="checkbox"/> Building Inspector	<input checked="" type="checkbox"/> Electrical Safety Inspector	<input type="checkbox"/> Fire Protection Inspector	<input type="checkbox"/> Mechanical Inspector
<input type="checkbox"/> Plumbing Inspector	<input type="checkbox"/> Non-Residential Industrial Unit Inspector			

<input type="checkbox"/> Res. Plans Examiner	<input type="checkbox"/> Res. Building Inspector
<input type="checkbox"/> Res. Industrial Unit Inspector	<input type="checkbox"/> Res. Mechanical Inspector

**SECTION 2: LIST ANY OHIO LICENSE, CERTIFICATE, OR REGISTRATION HELD**

(Mark "T" If Trainee)

Description		Certificate Number	Date Received
Architectural Registration			
P.E. Registration			
Res	Non-Res		
<input type="checkbox"/>	<input type="checkbox"/>	Building Official Certification	
<input type="checkbox"/>	<input type="checkbox"/>	Plans Examiner Certification	
<input type="checkbox"/>	<input type="checkbox"/>	Building Inspector Certification	
<input type="checkbox"/>	<input type="checkbox"/>	Mechanical Inspector Certification	
Building Plans Examiner Certification			
Mechanical Plans Examiner Certification			
Fire Protection Plans Examiner Certification			
Electrical Plans Examiner Certification			
Plumbing Plans Examiner Certification			
Fire Protection Inspector Certification			
Electrical Safety Inspector Certification			
Plumbing Inspector Certification			
Fire Safety Inspector Certification			
Fire Protection System Designer Certification			
Medical Gas Piping Inspector Certification			

**Section 3: Employment/Education**

a. Formal Education	Date Graduated
<u>New Richmond High School</u>	<u>2019</u>

Perrott  
Last Name

Aaron  
First Name

\_\_\_\_\_  
BBS Certification ID

b. Related Vocational or Technical Training	Years' Experience
Grant Career Center	2 yrs
Tulsa Welding School	15 months
c. U.S. Military construction experience (MOS or other designation):	Years' Experience
d. Place of Employment:	Years' Employed

**SECTION 4: OBC/RCO BUILDING INSPECTION EXPERIENCE PERFORMED FOR A BBS CERTIFIED BUILDING DEPARTMENT**

BBS Certified Building Department	BBS Certified Position/Title	Duties	Date of Service, Length of Time (MM/DD/YY)

**SECTION 5: EXPERIENCE (DO NOT SUBSTITUTE WITH OTHER RESUMES).**

Refer to Experience Requirements Listed in O.A.C. 4101:7-3-01 and O.R.C. 3783

Below, list the specific projects you worked on, and the specific work you performed, your typical duties for each project, and dates of this work. You must demonstrate that you have the required number of months (years) of actual, practical experience for the certification requested (see matrix).

Provide letters from certified inspectors, employers, or contractors verifying your experience. Submit copies of any certificates, diplomas, or licenses. Remove all personal information.

List Each Construction Project AND Specific Type of Work Performed	Name of Employer, Contact, Address, Telephone Number	Project Time: From_ To _ (MM/YY)
Example: Children's Hospital, Toledo Structural steel work on addition	Homer Steel and Trade 125 Anytown Street My City, OH, 45454 (419)555-1212	July 2013-May 2014 (10 months)
Total Experience on This Page (In Months):		

Prescott

Aaron

Last Name

First Name

BBS Certification ID

SECTION 5 CONT.: EXPERIENCE

List Each Construction Project AND Specific Type of Work Performed	Name of Employer, Contact, Address, Telephone Number	Project Time: From _ To _ (MM/YY)
UC Student housing-The Eden (Cincinnati) Building Service, Switch Gear, Roughing Metal & Wood Frame Running 1/2", 3/4", & 1" conduit Fire caulking	KEP Electric 7774 Ferris Rd Amelia, OH 45102 (513) 752-3043	June 2020 - September 2020 (4 months)
JR Green - Luxury Apartments (Covington) Building Service, Switch Gear, Roughing Wood Frame and parking garage, Running Conduit, Finish work. Fire alarm, Fire caulking Generator wiring, landing panels	KEP Electric 7774 Ferris Rd Amelia, OH 45102 (513) 752-3043	September 2020 - November 2021 (14 months)
Whiskey River - Apartments (Lawrenceburg) Building Service, Switch Gear Roughing Garage, Fire alarm	KEP Electric	March 2021 - June 2021 (4 months)
511 North Broadway Apartments (Lebanon) Building Service, Roughing Wood Frame, Fire Alarm, Finish work, underground Conduit	KEP Electric	November 2021 - January 2022 (3 months)
307 Bear Creek Road (Home) Full Electrical Rough & <del>Finish</del> Finish	A&K Company	September 2021 - November 2021
Total Experience on This Page (In Months):		

20211 Platt Rd Guilford,  
IN 47022 (513) 253-3640

Perrott  
Last Name

Aaron  
First Name

BBS Certification ID

SECTION 6: PERSONAL HISTORY

- 1. Have you ever been convicted of any felony, or any crime involving moral turpitude?  
If you answered "Yes" please explain below:  Yes  No
- 2. Have you served in the U.S. armed services? (If No, skip question 3)  Yes  No
- 3. If YES, were you discharged under honorable conditions?  Yes  No  
If you answered "No" please explain below:

SECTION 7: CERTIFICATION

*I certify the information contained in this application is true and complete, and I understand that providing false information may be grounds for not granting certification or for immediate termination of certification at any point in the future, if granted. I authorize the investigation of all statements contained herein and release all parties from all liability for any damage that may result from furnishing the same to Ohio Board of Building Standards. Falsification is a violation of section 2921.13 of the Ohio Revised Code and is punishable as a misdemeanor of the first degree.*

Signature of Applicant: Aaron W. Perrott

Subscribed and duly sworn before me according to law, by the above named applicant this day 18 of August in the year 2022 at New Richmond, County of Clermont and State of Ohio.

Notary Public: [Signature]  
Commission Exp: 9-9-2024



JO ELLEN LANSAW POWERS  
NOTARY PUBLIC - OHIO

Prescott

Aaron

Last Name

First Name

BBS Certification ID

OPTIONAL ALTERNATIVE TRAINEE PROGRAM PLAN FORM

Building Official, Supervisor and Applicant shall complete and submit this form with BBS Application for Trainee Certification only if Trainee Sponsor is proposing an alternative trainee program in lieu of the requirements of the traditional trainee program specified in OAC 4101:7-3-01(F)(5)(e). No Alternative Trainee Program may propose to waive examination requirements or attendance at the OBCA.

PROPOSED ALTERNATIVE PROGRAM PLAN DESCRIPTION

Attach additional pages if necessary and/or a letter describing the proposed program conditions.

Proposed Alternative Program Length: 1yr unless requirements met sooner

Proposed Alternative Program Education Requirements: 50 continuing education hours. Must complete code academy.

Proposed Alternative Program Training & Supervision Requirements: 300 supervised inspections. must complete examination requirements

Explanation of how the Proposed Alternative Program provides equivalent level of training and education based on the Applicant's experience documented in the application: We believe that the 300 supervised inspections will provide the potential trainee adequate hands on field experience. In addition the 50 continuing education hours as well as completing code academy and examinations will enhance his current skill set. Based off his existing background. He has a wide range of Residential/Commercial experience but falls short of the full amount of months required for full esi.

Applicant Signature: Aaron W. Prescott

Date: 8/15/22 esi.

Supervisor Signature: [Signature]

Date: 8/15/22

Building Official Signature: [Signature]

Date: 8/15/22

Prescott  
Last Name

Aaron  
First Name

\_\_\_\_\_  
BBS Certification ID

### BUILDING OFFICIAL CERTIFICATION OF TRAINEE AND SUPERVISOR

*Please complete this certification and return it with the BBS Application for Trainee Certification*

Application for participation in a BBS Trainee program is being made to the Board of Building Standards. I, Bruce Cross, Building Official for the political subdivision of Claymont County (Municipality, Township, County) do hereby acknowledge that the applicant, AARON PRESCOTT, and the assigned supervisor, ALEX WAKEFIELD are full-time employees of the above mentioned political subdivision.

Signature: Bruce Cross Date: 8/15/22

Prescott  
Last Name

Aaron  
First Name

\_\_\_\_\_  
BBS Certification ID

### SUPERVISOR CERTIFICATION OF TRAINEE

Please complete this certification and return it with the BBS Application for Trainee Certification.

Application for participation in a BBS trainee program is being made to the Board of Building Standards. I, Alex Wakefield, trainee supervisor for the political subdivision of Clermont County, (Municipality, Township, County) hold certification as a ESI, Certification ID# 6376, effective until \_\_\_\_\_, and hereby consent and agree to supervise the work of Aaron Prescott (Applicant) as a Building Department Trainee pursuant to section 4101:7-3-01(F)(5)(b) of the Ohio Administrative Code.

Number of Trainees presently supervised (including this applicant):

\_\_\_\_\_ One

X Two

Signature:  Date: 8/15/22



**File Attachments for Item:**

P-8 Sanson, Joseph RBO

Certification ID# 8928

Current certifications- none

Staff notes: Need additional information on PE status, work listed on application. Request sent via email 9/13

Committee recommendation:

# Board of Building Standards

Application for Interim Certification, Building Department Personnel

Sanson

Last Name

Joseph

First Name

# 86

BBS Certification ID

## SECTION 1: CHECK INTERIM CERTIFICATION(S) BEING REQUESTED

<input checked="" type="checkbox"/> Res. Building Official	<input type="checkbox"/> Res. Plans Examiner	<input type="checkbox"/> Res. Building Inspector
<input type="checkbox"/> Res. Industrial Unit Inspector	<input type="checkbox"/> Res. Mechanical Inspector	

## SECTION 2: LIST ANY OHIO LICENSE, CERTIFICATE, OR REGISTRATION HELD

(Mark "T" If Trainee)

Description		Certificate Number	Date Received
Architectural Registration			
P.E. Registration			
Res	Non-Res		
<input type="checkbox"/>	<input type="checkbox"/>	Building Official Certification	
<input type="checkbox"/>	<input type="checkbox"/>	Plans Examiner Certification	
<input type="checkbox"/>	<input type="checkbox"/>	Building Inspector Certification	
<input type="checkbox"/>	<input type="checkbox"/>	Mechanical Inspector Certification	
Building Plans Examiner Certification			
Mechanical Plans Examiner Certification			
Fire Protection Plans Examiner Certification			
Electrical Plans Examiner Certification			
Plumbing Plans Examiner Certification			
Fire Protection Inspector Certification			
Electrical Safety Inspector Certification			
Plumbing Inspector Certification			
Fire Safety Inspector Certification			
Fire Protection System Designer Certification			
Medical Gas Piping Inspector Certification			

## Section 3: Employment/Education

a. Formal Education	Date Graduated
Masters in Civil Engineering-Youngstown State University	May 18, 2013
Bachelor of Engineering-Civil Engineering-Youngstown State	June 19, 1993
b. Related Vocational or Technical Training	Years' Experience
c. U.S. Military construction experience (MOS or other designation):	Years' Experience
d. Place of Employment:	Years' Employed
City of Girard	1 Month
Youngstown State University	14 Years

# Board of Building Standards

Application for Interim Certification, Building Department Personnel

Sanson

Joseph

#86

Last Name

First Name

BBS Certification ID

## SECTION 4: OBC/RCO BUILDING INSPECTION EXPERIENCE PERFORMED FOR A BBS CERTIFIED BUILDING DEPARTMENT

BBS Certified Building Department	BBS Certified Position/Title	Duties	Date of Service, Length of Time (MM/DD/YY)

## SECTION 5: EXPERIENCE (DO NOT SUBSTITUTE WITH OTHER RESUMES).

Refer to Experience Requirements Listed in O.A.C. 4101:7-3-01 and O.R.C. 3783

Below, list the specific projects you worked on, and the specific work you performed, your typical duties for each project, and dates of this work. You **must** demonstrate that you have the required number of months (years) of actual, practical experience for the certification requested (see matrix).

Provide letters from certified inspectors, employers, or contractors verifying your experience. Submit copies of any certificates, diplomas, or licenses. Remove all personal information.

List Each Construction Project AND Specific Type of Work Performed	Name of Employer, Contact, Address, Telephone Number	Project Time: From_ To _ (MM/YY)
<p><i>Example:</i> Children's Hospital, Toledo Structural steel work on addition</p>	<p>Homer Steel and Trade 125 Anytown Street My City, OH, 45454 (419)555-1212</p>	<p>July 2013-May 2014 (10 months)</p>
<p>Projects #1 Various Commercial Projects, Project Manager over a six-year period.</p>	<p>Daniela A. Terreri &amp; Sons, Inc. 1091 N. Meridian Road. Youngstown, Ohio Daniel Terreri-330-502-4314</p>	<p>01/1996 - 2001</p>
<p>Projects #2 Various Commercial Projects, Project Managed over a two year Period.</p>	<p>DOT Construction Corp. Canfield, Ohio Dave Spurio - 330-727-2535</p>	<p>2001 - 2003</p>
<p><b>Total Experience on This Page (In Months):</b></p>		<p><b>108 Months</b></p>

# Board of Building Standards

Application for Interim Certification, Building Department Personnel

Sanson

Joseph

#86

Last Name

First Name

BBS Certification ID

## SECTION 5 CONT.: EXPERIENCE

List Each Construction Project <b>AND</b> Specific Type of Work Performed	Name of Employer, Contact, Address, Telephone Number	Project Time: From _ To _ (MM/YY)
<p>Projects #3</p> <p>Various Commercial Projects, Project Managed over a 4 year Period.</p>	<p>D.S. Contracting 1090 N. Meridian Road Youngstown, Ohio</p>	<p>2003-2007</p>
<p>Projects #4</p> <p>Various Commercial and Industrial projects. Scheduling, Reserve Study Investigations, and Cost Segregations.</p>	<p>J.R. Johnson Engineering, Inc. 6673 Eastland Road Cleveland, Ohio 44130</p>	<p>June 2007-June 2009</p>
<p>Projects #5</p> <p>Associate Professor Civil Engineering Technology. Course Instruction: Soil Mechanics Masonry Design Concrete Design Structural Design Specs and Estimating</p>	<p>Youngstown State University One University Plaza Youngstown, Ohio 44437</p>	<p>August 2009-Present</p>
<p><b>Total Experience on This Page (In Months):</b></p>		<p><b>72 Months</b></p>

# Board of Building Standards

Application for Interim Certification, Building Department Personnel

Sanson

Joseph

#86

Last Name

First Name

BBS Certification ID

## SECTION 6: PERSONAL HISTORY

1. Have you ever been convicted of any felony, or any crime involving moral turpitude?  Yes  No
2. If you answered "Yes" please explain below:
3. Have you served in the U.S. armed services? (If No, skip question 3)  Yes  No
4. If YES, were you discharged under honorable conditions?  Yes  No  
If you answered "No" please explain below:

## SECTION 7: CERTIFICATION

I certify the information contained in this application is true and complete, and I understand that providing false information may be grounds for not granting certification or for immediate termination of certification at any point in the future, if granted. I authorize the investigation of all statements contained herein and release all parties from all liability for any damage that may result from furnishing the same to Ohio Board of Building Standards. Falsification is a violation of section 2921.13 of the Ohio Revised Code and is punishable as a misdemeanor of the first degree.

Signature of Applicant: 

Subscribed and duly sworn before me according to law, by the above named applicant this day 19th of July in the year 2022 at City of Gerard, County of Trumbull and State of Ohio.

Notary Public: 

my commission expires 10-15-2023

SEAL

**File Attachments for Item:**

P-9 Grusenmeyer, Jeffrey - ESI, PI, BI

Cert ID: 568

Current Certifications: BO, MPE, RBO

Staff Notes: As discussed at August 25 meeting, applicant has decades of experience designing all building systems and inspecting installation for owner approval. Recommend approval

Committee recommendation:

GRUSENMEYER  
Last Name

JEFFREY  
First Name

568  
BBS Certification ID

**SECTION 1: CHECK INTERIM CERTIFICATION(S) BEING REQUESTED**

<input type="checkbox"/> Building Official	<input type="checkbox"/> Master Plans Examiner	<input checked="" type="checkbox"/> Building Inspector	<input checked="" type="checkbox"/> Electrical Safety Inspector	<input type="checkbox"/> Fire Protection Inspector
<input type="checkbox"/> Building Plans Examiner	<input type="checkbox"/> Plumbing Plans Examiner	<input type="checkbox"/> Mechanical Plans Examiner	<input type="checkbox"/> Electrical Plans Examiner	<input type="checkbox"/> Fire Protection Plans Examiner
	<input checked="" type="checkbox"/> Plumbing Inspector	<input type="checkbox"/> Mechanical Inspector	<input type="checkbox"/> Non-Residential Industrial Unit Inspector	

**SECTION 2: LIST ANY OHIO LICENSE, CERTIFICATE, OR REGISTRATION HELD**

(Mark "T" If Trainee)

Description		Certificate Number	Date Received
Architectural Registration		7475	09/09/1983
P.E. Registration			
Res	Non-Res		
<input type="checkbox"/>	<input checked="" type="checkbox"/>	568	02/12/1996
<input type="checkbox"/>	<input checked="" type="checkbox"/>	568	01/08/1988
<input type="checkbox"/>	<input type="checkbox"/>		
<input type="checkbox"/>	<input type="checkbox"/>		
Building Official Certification			
Plans Examiner Certification			
Building Inspector Certification			
Mechanical Inspector Certification			
Building Plans Examiner Certification			
Mechanical Plans Examiner Certification			
Fire Protection Plans Examiner Certification			
Electrical Plans Examiner Certification			
Plumbing Plans Examiner Certification			
Fire Protection Inspector Certification			
Electrical Safety Inspector Certification			
Plumbing Inspector Certification			
Fire Safety Inspector Certification			
Fire Protection System Designer Certification			
Medical Gas Piping Inspector Certification			

GRUSEHMEYER  
Last Name

JEFFREY  
First Name

568  
BBS Certification ID

**SECTION 3: EMPLOYMENT/EDUCATION**

Formal Education	Date Graduated
UNIVERSITY OF DETROIT SCHOOL OF ARCHITECTURE (BARCA) PROFESSIONAL DEGREE IN ARCHITECTURE	MAY 1981
Related Vocational or Technical Training	Years' Experience
U.S. Military construction experience (MOS or other designation):	Years' Experience
Place of Employment:	Years' Employed

**SECTION 4: APPLICANTS REQUESTING MEDICAL GAS INSPECTOR CERTIFICATION**

*Attach proof of certification by an ASSE recognized third-party certifier in accordance with ASSE standard 6020.*

**SECTION 5: OBC BUILDING INSPECTION EXPERIENCE PERFORMED FOR A BBS CERTIFIED BUILDING DEPARTMENT**

BBS Certified Building Department	BBS Certified Position/Title	Duties	Date of Service, Length of Time (MM/DD/YY)
NORTH CUMSTED	MPE CBO	MPE CBO	1988-91, 2003-2022
LAKEWOOD	MPE	MPE	2013-2022
AVON LAKE	MPE	MPE	1989-2022
SHAKER ATS	MPE	MPE	1988-2022
AVON	MPE	MPE	2007-2016
FAIRVIEW PARK	MPE	MPE	2007-2012
WESTLAKE	MPE	MPE	1989-2012
			2004-2005



GRUSEN MEYER  
Last Name

JEFFREY  
First Name

568  
BBS Certification ID

**SECTION 6: ELECTRICAL SAFETY INSPECTOR (ESI) - SPECIFIC EXPERIENCE QUALIFICATIONS**

Applicants for Electrical Safety Inspector Only Must Complete This Item

Section 3783 of the Ohio Revised Code specifies that an applicant for a Certificate of Competency as an Electrical Safety Inspector must meet one of the following to qualify to take required examination. Please check the qualification that applies:

1.  Have been a journeyman electrician or equivalent for four years, two of which were as an electrician foreman, and have had two years' experience as a building department electrical inspector trainee;
2.  Have been a journeyman electrician or equivalent for four years and have had three years' experience as a building department electrical inspector trainee;
3.  Have had for four years' experience as a building department electrical inspector trainee;
4.  Have been a journeyman electrician or equivalent for six years;
5.  Am a graduate electrical engineer and registered in the State of Ohio. Registration number: EQUIVALENT, SEE ATTACHED
6.  Applicant authorizes all testing organizations including ICC to provide test results to the BBS.

**SECTION 7: EXPERIENCE (DO NOT SUBSTITUTE WITH OTHER RESUMES).**

Refer to Experience Requirements Listed in O.A.C. 4101:7-3-01 and O.R.C. 3783

Below, list the specific projects you worked on, and the specific work you performed, your typical duties for each project, and dates of this work. You **must** demonstrate that you have the required number of months (years) of actual, practical experience for the certification requested (see matrix).

Provide letters from certified inspectors, employers, or contractors verifying your experience. Submit copies of any certificates, diplomas, or licenses. Remove all personal information.

**SECTION 7 CONT.: EXPERIENCE**

List Each Construction Project <u>AND</u> Specific Type of Work Performed	Name of Employer, Contact, Address, Telephone Number	Project Time: From _ To _ (MM/YY)
<p>Example: Children's Hospital, Toledo Structural steel work on addition</p> <p><u>DESIGN ARCHITECT INCLUDING ELECTRICAL DESIGN FOR PROJECTS TOO NUMEROUS TO LIST. SEE ALSO JAGASSOC.COM.</u></p>	<p>Homer Steel and Trade 125 Anytown Street My City, OH, 45454 (419)555-1212</p>	<p>July 2013-May 2014 (10 months)</p>
<p><b>Total Experience on This Page (In Months):</b></p>		

**Board of Building Standards**

Application for Interim Certification, Building Department Personnel

GRUSENMEYER  
Last Name

JEFFREY  
First Name

568  
BBS Certification ID

List Each Construction Project <u>AND</u> Specific Type of Work Performed	Name of Employer, Contact, Address, Telephone Number	Project Time: From_ To _ (MM/YY)
Total Experience on This Page (In Months):		

GRUSENMEYER  
Last Name

JEFFREY  
First Name

568  
BBS Certification ID

**SECTION 8: PERSONAL HISTORY**

1. Have you ever been convicted of any felony, or any crime involving moral turpitude?  
 Yes  No

If you answered "Yes" please explain below:

2. Have you served in the U.S. armed services? (If No, skip question 3)  Yes  No

3. If YES, were you discharged under honorable conditions?  Yes  No

If you answered "No" please explain below:

**SECTION 9: CERTIFICATION**

*I certify the information contained in this application is true and complete, and I understand that providing false information may be grounds for not granting certification or for immediate termination of certification at any point in the future, if granted. I authorize the investigation of all statements contained herein and release all parties from all liability for any damage that may result from furnishing the same to Ohio Board of Building Standards. Falsification is a violation of section 2921.13 of the Ohio Revised Code and is punishable as a misdemeanor of the first degree.*

Signature of Applicant: *Jeffrey Grusenmeyer*

Subscribed and duly sworn before me according to law, by the above named applicant this day 19<sup>th</sup> of Sept in the year 2022 at First Federal (akron) County of Cuyahoga and State of Ohio.

Notary Public: *[Signature]*



TIFFANY HILL  
Notary Public, State of Ohio  
My Commission Expires  
January 24, 2024  
Recorded in Cuyahoga County



President  
JEFFREY A. GRUSENMEYER RA NCARB  
Master Plans Examiner, Building Official,  
Residential Building official

Vice President of Project Development  
JASON D. GALDUN RA NCARB

September 19, 2022

Regina Hanshaw  
Ohio Board of Building Standards

RE: ESI

Dear Ms. Hanshaw:

Attached is the completed application. The following information further explains the answers given:

I am a registered architect who has designed electrical systems for both commercial and public agency projects for almost 39 years. As a part of this work I also inspect the systems for acceptance by the Owner, both public and private, on a regular basis.

In addition, I hold both master plans examiner and building official certifications where, on a regular basis, I review and approve electrical plans (for over 30 years) and approve, oversee, and decide/settle all questions regarding electrical inspection from ESI inspectors with a number of certified building departments, including 10 years as the primary BO for a large commercial department at North Olmsted.

As a matter of Ohio registration law, an architect is permitted to design and seal electrical systems for the design work they perform, which I do.

Please let me know if there are any questions.

Sincerely,

Jeffrey A. Grusenmeyer, RA, NCARB, President  
JEFFREY A. GRUSENMEYER & ASSOCIATES, INC., ARCHITECTS

ESI Qualifications Statement



**Education**

University of Detroit School of Architecture – Graduated Magna Cum Laude with a Professional Degree in Architecture, Insignis Scholar, (a scholarship awarded to the top 10 students entering the University), Member of Alpha Sigma Nu, the National Jesuit Honor Society for the top 2 graduates of the School in academics, loyalty and service.

**Responsibilities**

- ◆ Program management, owner consultant coordination, project presentation, evaluation of project budget and estimate of cost of the work, schedule development & monitoring, value analysis.
- ◆ Programming, economic feasibility surveys, site analysis, site development planning.
- ◆ Design services, material research and specifications.
- ◆ Bidding/ proposal documents, analysis of alternates and substitutions, pre-bid conference/ selections interviews, bidding/ negotiating, bid/ proposal evaluation.
- ◆ General administration, interpretations and decisions, project close-out, construction management, post contract evaluation.
- ◆ Code Consultation, plan review, building department administration and consultation.

**Relevant Project Experience**

**PLAN REVIEW, CODE AND CIVIC CONSULTATION**

- |  |  |  |
|--|--|--|
| ◆ City of North Olmsted, Ohio<br>1988-1991; 2003-Present | ◆ City of Fairview Park, Ohio<br>1989-2012   | ◆ City of Vermilion, Ohio<br>2000                    |
| ◆ City of Lakewood, Ohio<br>1989-Present                 | ◆ City of Westlake<br>2004-2005  | ◆ City of North Royalton, Ohio 2012.                 |
| ◆ City of Avon Lake, Ohio<br>1988-2022                   | ◆ City of Cleveland, Ohio<br>Independent Master Plans Examiner by<br>Contract<br>2001- | ◆ City of Berea, Ohio 2011-2015                      |
| ◆ City of Shaker Heights, Ohio<br>2007-2016              | ◆ City of Sheffield Village, Ohio<br>1999  | ◆ Building Industry Association of Cleveland<br>1997 |
| ◆ City of Avon, Ohio<br>2007-2012                        |  | ◆ CitiCorp of Chicago<br>1997                        |

**An extensive list of other project experience in the following specialties is available upon request:  
EDUCATIONAL & RECREATIONAL, CIVIC, RELIGIOUS, COMMERCIAL, MEDICAL, RETAIL,  
MANUFACTURING/INDUSTRIAL, FOOD SERVICE/RESTAURANT, AND RESIDENTIAL FACILITES**

**Professional Registrations**

- ◆ Ohio, Pennsylvania, West Virginia, Michigan
- ◆ NCARB Certified – National/ International certification by the National Council of Architectural Registration Boards.
- ◆ Certified as a Chief Building Official by the Council of American Building Officials and the State of Ohio.
- ◆ Certified as a Building Official by the State of Ohio.
- ◆ Certified as a Master Plans Examiner by the State of Ohio.
- ◆ Certified as a Residential Building Official by the State of Ohio.
- ◆ FAA Airman Certificate-Private Pilot

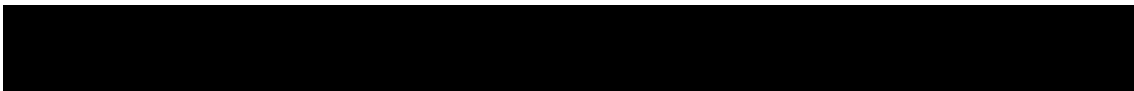

## Approved Courses and Publications

- ◆ Ohio Board of Building Standards Approved Courses:
  - Building Physics and the Rain Screen Principle-The Building Envelope.
  - Construction Documents and the Universal Drawing System
  - Building Department/Fire Department Relationships and Responsibilities
  - Principles of Materials I-Concrete
  - Principles of Materials II-Wood

## Professional Experience

- ◆ Principle Architect in a firm established in 1983, providing design services on a wide range of projects, including civic, commercial, educational, medical, and code consultation work, and dedicated to serving the individual needs of the client.
- ◆ Adjunct Professor at Kent State University College of Architecture and Environmental Design teaching Construction Methods and Materials I and II, building code and construction documents 2009-2014.
- ◆ Projects by Jeffrey A. Grusenmeyer & Associates, Inc. have been the feature design of the American Institute of Architects Cleveland Chapter Newsletter and the Steel Joist Institute web site Featured Project, one of four selected nationally for the innovative use of steel joist systems.
- ◆ Previous experience prior to the private practice includes work with Albert Kahn Associated Architects and Engineers in Detroit, Michigan; Ventura & Associates, Architects & Engineers in Detroit, Michigan; T.A. Badowski, A.I.A, Architects in Lakewood, Ohio; Argentieri Associates & Planners in Cleveland, Ohio; and the King James Group of Westlake, Ohio.
- ◆ Building Commissioner to the City of North Olmsted, Ohio 2013-Present.

## Organizations

- ◆ Board member Lakewood Senior Citizens, Inc.
- ◆ Served as a member of the American Institute of Architects, the AIA Building Codes and Standards and Committee on Architecture for Education Professional Interest Areas, the Building Officials Conference of Northeast Ohio, FBOA Building Officials Association.
- ◆ Member of the North Central Ohio Building Officials Association, and the Ohio Building Officials Association.
- ◆ Served as President of the Fairview Park Chamber of Commerce, having served as a member of the Board of Directors, incorporator, and charter member. Member of the Greater Cleveland Growth Association. Former member of the Rocky River and Westlake Chambers of Commerce.
- ◆ Rotary International, Paul Harris Fellow
- ◆ Served on the City of Fairview Park Planning & Design Commission 1990-2004, serving as chairman for most of those years. Former chairman and member of the City of Fairview Park Architectural Board of Review.
- ◆ Served as a member of the Lorain Road Business Development Committee, City of Fairview Park Master Plan Committee, Fairview Park City School District Facilities Committee, and the City of Fairview Park Commercial District Design Guideline Committee.
- ◆ Coach of boys and girls traveling soccer teams and recreation league soccer, baseball and softball teams. Certified as a soccer coach by the United States Soccer Association No. E1753. Board Member and Treasurer of the Fairview Park Soccer Association 2006-2010.
- ◆ Recipient of the North Central Ohio Building Officials Association Associate of the Year in 2003- for Dedication and Service to the Communities in Which the Associate Serves.



President  
JEFFREY A. GRUSENMEYER RA NCARB  
Master Plans Examiner, Building Official,  
Residential Building official

Vice President of Project Development  
JASON D. GALDUN RA NCARB

September 19, 2022

Regina Hanshaw  
Ohio Board of Building Standards

RE: PI

Dear Ms. Hanshaw:

I am a registered architect who has designed plumbing systems for both commercial and public agency projects for almost 39 years. As a part of this work I also inspect the systems for acceptance by the Owner, both public and private, on a regular basis.

In addition, I hold both master plans examiner and building official certifications where, on a regular basis, I review and approve plumbing plans (for over 30 years) and approve, oversee, and decide/settle all questions regarding plumbing inspection from plumbing inspectors with a number of certified building departments, including 10 years as the primary BO for a large commercial department at North Olmsted.

As a matter of Ohio registration law, an architect is permitted to design and seal plumbing systems for the design work they perform, which I do.

Please let me know if there are any questions.

Sincerely,

Jeffrey A. Grusenmeyer, RA, NCARB, President  
JEFFREY A. GRUSENMEYER & ASSOCIATES, INC., ARCHITECTS

PI Qualifications Statement

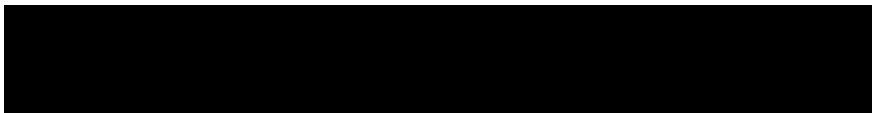

**File Attachments for Item:**

P-10 Neff, Matthew - ESI

Cert ID:

Current Certifications: None

Staff notes: Requested journeyman card, electrical contractor's license via email 9/19

Committee Recommendation:



Neff  
Last Name

Matthew  
First Name

\_\_\_\_\_  
BBS Certification ID

**SECTION 1: CHECK INTERIM CERTIFICATION(S) BEING REQUESTED**

<input type="checkbox"/> Building Official	<input type="checkbox"/> Master Plans Examiner	<input type="checkbox"/> Building Inspector	<input checked="" type="checkbox"/> Electrical Safety Inspector	<input type="checkbox"/> Fire Protection Inspector
<input type="checkbox"/> Building Plans Examiner	<input type="checkbox"/> Plumbing Plans Examiner	<input type="checkbox"/> Mechanical Plans Examiner	<input type="checkbox"/> Electrical Plans Examiner	<input type="checkbox"/> Fire Protection Plans Examiner
	<input type="checkbox"/> Plumbing Inspector	<input type="checkbox"/> Mechanical Inspector	<input type="checkbox"/> Non-Residential Industrial Unit Inspector	

**SECTION 2: LIST ANY OHIO LICENSE, CERTIFICATE, OR REGISTRATION HELD**

(Mark "T" if Trainee)

Description		Certificate Number	Date Received
Architectural Registration			
P.E. Registration			
Res	Non-Res		
<input type="checkbox"/>	<input type="checkbox"/>	Building Official Certification	
<input type="checkbox"/>	<input type="checkbox"/>	Plans Examiner Certification	
<input type="checkbox"/>	<input type="checkbox"/>	Building Inspector Certification	
<input type="checkbox"/>	<input type="checkbox"/>	Mechanical Inspector Certification	
Building Plans Examiner Certification			
Mechanical Plans Examiner Certification			
Fire Protection Plans Examiner Certification			
Electrical Plans Examiner Certification			
Plumbing Plans Examiner Certification			
Fire Protection Inspector Certification			
Electrical Safety Inspector Certification			
Plumbing Inspector Certification			
Fire Safety Inspector Certification			
Fire Protection System Designer Certification			
Medical Gas Piping Inspector Certification			

Neff  
Last Name

Matthew  
First Name

\_\_\_\_\_  
BBS Certification ID

**SECTION 3: EMPLOYMENT/EDUCATION**

Formal Education	Date Graduated
Marion Harding High School	June 1994
Related Vocational or Technical Training	Years' Experience
AEC-IEC Electrical Apprenticeship IBEW 688 continuing education	96-2000
U.S. Military construction experience (MOS or other designation):	Years' Experience
Place of Employment:	Years' Employed
Neff Electrical Construction Co.	30

**SECTION 4: APPLICANTS REQUESTING MEDICAL GAS INSPECTOR CERTIFICATION**

*Attach proof of certification by an ASSE recognized third-party certifier in accordance with ASSE standard 6020.*

**SECTION 5: OBC BUILDING INSPECTION EXPERIENCE PERFORMED FOR A BBS CERTIFIED BUILDING DEPARTMENT**

BBS Certified Building Department	BBS Certified Position/Title	Duties	Date of Service, Length of Time (MM/DD/YY)
N/A			

Neff  
Last Name

Matthew  
First Name

BBS Certification ID

**SECTION 6: ELECTRICAL SAFETY INSPECTOR (ESI) - SPECIFIC EXPERIENCE QUALIFICATIONS**

Applicants for Electrical Safety Inspector Only Must Complete This Item

Section 3783 of the Ohio Revised Code specifies that an applicant for a Certificate of Competency as an Electrical Safety Inspector must meet one of the following to qualify to take required examination. Please check the qualification that applies:

1.  Have been a journeyman electrician or equivalent for four years, two of which were as an electrician foreman, and have had two years' experience as a building department electrical inspector trainee;
2.  Have been a journeyman electrician or equivalent for four years and have had three years' experience as a building department electrical inspector trainee;
3.  Have had for four years' experience as a building department electrical inspector trainee;
4.  Have been a journeyman electrician or equivalent for six years;
5.  Am a graduate electrical engineer and registered in the State of Ohio. Registration number: \_\_\_\_\_
6.  Applicant authorizes all testing organizations including ICC to provide test results to the BBS.

**SECTION 7: EXPERIENCE (DO NOT SUBSTITUTE WITH OTHER RESUMES).**

Refer to Experience Requirements Listed in O.A.C. 4101:7-3-01 and O.R.C. 3783

Below, list the specific projects you worked on, and the specific work you performed, your typical duties for each project, and dates of this work. You must demonstrate that you have the required number of months (years) of actual, practical experience for the certification requested (see matrix).

Provide letters from certified inspectors, employers, or contractors verifying your experience. Submit copies of any certificates, diplomas, or licenses. Remove all personal information.

List Each Construction Project <u>AND</u> Specific Type of Work Performed	Name of Employer, Contact, Address, Telephone Number	Project Time: From_ To _ (MM/YY)
<p>Example: Children's Hospital, Toledo Structural steel work on addition</p>	<p>Homer Steel and Trade 125 Anytown Street My City, OH, 45454 (419)555-1212</p>	<p>July 2013-May 2014 (10 months)</p>
<p>Graphic Packaging Maintenance &amp; Electrical Installs.</p> <p>Commercial &amp; Residential Service Calls</p>	<p>Neff Electric 2032 Harding Hwy E. Marion, OH 43302 740-383-4308</p> <p style="text-align: center;">↓</p>	<p>1-1-16 to Present</p> <p style="text-align: right;">24 months</p>
<p>Total Experience on This Page (In Months):</p>		<p>48 months</p>

Neff  
Last Name

Matt New  
First Name

BBS Certification ID

SECTION 7 CONT.: EXPERIENCE

List Each Construction Project AND Specific Type of Work Performed	Name of Employer, Contact, Address, Telephone Number	Project Time: From_ To_ (MM/YY)
Marion Public Library Bathroom Remodels new fixtures, Hand Dryers & Fire Alarm additions.	Neff Electric 2032 Harding Hwy E. Marion, OH 43302 740-383-4308	7-6-16 1-4-17 6 mos.
ATK Delaware 400A. Feeder & new equip. Connections	↓	9-11-16 8-5-17 6 mos.
HFM Yazumi Iberia, OH office Renovation 2 new Sub panels & new wiring for offices, kitchen & conference room		4-5-17 5-5-18 12 mos.
Marion YMCA Wellness Ctr. Sub panel & new fixtures devices		8-20-18 5-6-19 6 mos.
Pinnacle Marion, OH complete rewire from existing Elec. service		8-25-19 6 mos. 2-10-20
Angeline Industries, Upper New service & complete rewire of existing building		4-5-20 12 mos. 5-5-21
Leap In Ministries 2-600A. Services		5-17-21 4 mos. 9-20-21
Marion County Republican Hq Complete Rewire		5-18-21 10 mos. present
<b>Total Experience on This Page (In Months):</b>		<b>62 months</b>

Neff  
Last Name

Matthew  
First Name

BBS Certification ID

**SECTION 8: PERSONAL HISTORY**

1. Have you ever been convicted of any felony, or any crime involving moral turpitude?

Yes  No

If you answered "Yes" please explain below:

2. Have you served in the U.S. armed services? (If No, skip question 3)

Yes  No

3. If YES, were you discharged under honorable conditions?  Yes

No

If you answered "No" please explain below:

**SECTION 9: CERTIFICATION**

I certify the information contained in this application is true and complete, and I understand that providing false information may be grounds for not granting certification or for immediate termination of certification at any point in the future, if granted. I authorize the investigation of all statements contained herein and release all parties from all liability for any damage that may result from furnishing the same to Ohio Board of Building Standards. Falsification is a violation of section 2921.13 of the Ohio Revised Code and is punishable as a misdemeanor of the first degree.

Signature of Applicant: *M. Neff*

Subscribed and duly sworn before me according to law, by the above named applicant this day 11<sup>th</sup> of July in the year 2022 at Marion, County of Marion and State of Ohio.

Notary Public: *Jill Temple*

SEAL

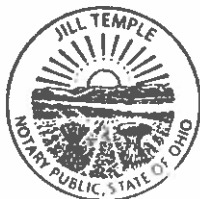

JILL TEMPLE  
NOTARY PUBLIC  
STATE OF OHIO  
My Comm. Expires  
10.3.23

**File Attachments for Item:**

C-1 Ashley, Alan - BO

Certification ID# 5783

Current certifications- BI, RBO

**Board of Building Standards**

Application for Interim Certification, Building Department Personnel

Ashley

Alan

5783

*Last Name*

*First Name*

*BBS Certification ID*

**SECTION 1: CHECK INTERIM CERTIFICATION(S) BEING REQUESTED**

<input checked="" type="checkbox"/> Building Official	<input type="checkbox"/> Master Plans Examiner	<input type="checkbox"/> Building Inspector	<input type="checkbox"/> Electrical Safety Inspector	<input type="checkbox"/> Fire Protection Inspector
<input type="checkbox"/> Building Plans Examiner	<input type="checkbox"/> Plumbing Plans Examiner	<input type="checkbox"/> Mechanical Plans Examiner	<input type="checkbox"/> Electrical Plans Examiner	<input type="checkbox"/> Fire Protection Plans Examiner
	<input type="checkbox"/> Plumbing Inspector	<input type="checkbox"/> Mechanical Inspector	<input type="checkbox"/> Non-Residential Industrial Unit Inspector	

**SECTION 2: LIST ANY OHIO LICENSE, CERTIFICATE, OR REGISTRATION HELD**

(Mark "T" If Trainee)

Description		Certificate Number	Date Received
Architectural Registration			
P.E. Registration			
Res	Non-Res		
<input checked="" type="checkbox"/>	<input type="checkbox"/>	Building Official Certification	5783 2018
<input type="checkbox"/>	<input checked="" type="checkbox"/>	Plans Examiner Certification	<i>Interim</i> 2022
<input type="checkbox"/>	<input checked="" type="checkbox"/>	Building Inspector Certification	5783 2018
<input type="checkbox"/>	<input type="checkbox"/>	Mechanical Inspector Certification	
Building Plans Examiner Certification			
Mechanical Plans Examiner Certification			
Fire Protection Plans Examiner Certification			
Electrical Plans Examiner Certification			
Plumbing Plans Examiner Certification			
Fire Protection Inspector Certification			
Electrical Safety Inspector Certification			
Plumbing Inspector Certification			
Fire Safety Inspector Certification			
Fire Protection System Designer Certification			
Medical Gas Piping Inspector Certification			

# Board of Building Standards

Application for Interim Certification, Building Department Personnel

Ashley  
Last Name

Alan  
First Name

5783  
BBS Certification ID

### SECTION 3: EMPLOYMENT/EDUCATION

Formal Education	Date Graduated
Park Hills High School	June 1978
Related Vocational or Technical Training	Years' Experience
Sinclair College	One year
Ashworth College - Home Improvement Certification	
U.S. Military construction experience (MOS or other designation):	Years' Experience
51R10 (Electrician), 76th Engineer Battalion, US Army	4 years
Place of Employment:	Years' Employed
Montgomery County Building Regulations Dept	4-1/2 years

### SECTION 4: APPLICANTS REQUESTING MEDICAL GAS INSPECTOR CERTIFICATION

*Attach proof of certification by an ASSE recognized third-party certifier in accordance with ASSE standard 6020.*

### SECTION 5: OBC BUILDING INSPECTION EXPERIENCE PERFORMED FOR A BBS CERTIFIED BUILDING DEPARTMENT

BBS Certified Building Department	BBS Certified Position/Title	Duties	Date of Service, Length of Time (MM/DD/YY)
Montgomery County Building Regulations	Building Inspector	Performs commercial and residential building inspections to verify compliance with State of Ohio building codes for residential and commercial/industrial buildings.	Dec 2017-present



Ashley  
Last Name

Alan  
First Name

5783  
BBS Certification ID

**SECTION 6: ELECTRICAL SAFETY INSPECTOR (ESI) - SPECIFIC EXPERIENCE QUALIFICATIONS**

Applicants for Electrical Safety Inspector Only Must Complete This Item

Section 3783 of the Ohio Revised Code specifies that an applicant for a Certificate of Competency as an Electrical Safety Inspector must meet one of the following to qualify to take required examination. Please check the qualification that applies:

1.  Have been a journeyman electrician or equivalent for four years, two of which were as an electrician foreman, and have had two years' experience as a building department electrical inspector trainee;
2.  Have been a journeyman electrician or equivalent for four years and have had three years' experience as a building department electrical inspector trainee;
3.  Have had for four years' experience as a building department electrical inspector trainee;
4.  Have been a journeyman electrician or equivalent for six years;
5.  Am a graduate electrical engineer and registered in the State of Ohio. Registration number: \_\_\_\_\_
6.  Applicant authorizes all testing organizations including ICC to provide test results to the BBS.

**SECTION 7: EXPERIENCE (DO NOT SUBSTITUTE WITH OTHER RESUMES).**

Refer to Experience Requirements Listed in O.A.C. 4101:7-3-01 and O.R.C. 3783

Below, list the specific projects you worked on, and the specific work you performed, your typical duties for each project, and dates of this work. You must demonstrate that you have the required number of months (years) of actual, practical experience for the certification requested (see matrix).

Provide letters from certified inspectors, employers, or contractors verifying your experience. Submit copies of any certificates, diplomas, or licenses. Remove all personal information.

**SECTION 7 CONT.: EXPERIENCE**

List Each Construction Project <u>AND</u> Specific Type of Work Performed	Name of Employer, Contact, Address, Telephone Number	Project Time: From _ To _ (MM/YY)
<p><i>Example:</i> Children's Hospital, Toledo Structural steel work on addition</p> <p>Joined carpenter's Union August 1986</p> <p>Hired @ LB Robinson 1st project Wright Patterson AFB 3-story addition. Formed footers; tied rebar; poured footers; installed Simons forms, 8' walls; prepped for slab; set door jambs, metal studs; hung drywall</p> <p>(continued)</p>	<p>Homer Steel and Trade 125 Anytown Street My City, OH, 45454 (419)555-1212</p> <p>LB Robinson</p>	<p>July 2013-May 2014 (10 months)</p> <p>August 1986- Jan 1987</p>
<b>Total Experience on This Page (In Months):</b>		

**Board of Building Standards**

Application for Interim Certification, Building Department Personnel

Ashley  
Last Name

Alan  
First Name

5783  
BBS Certification ID

List Each Construction Project <u>AND</u> Specific Type of Work Performed	Name of Employer, Contact, Address, Telephone Number	Project Time: From_ To _ (MM/YY)
Cub Foods Tied steel and set sona tubs for parking lot lights	LB Robinson	Jan 1987- March 1987
St. Mary's Church Set batter boards; installed footer forms; tied steel; poured footers; set wall forms; poured walls; prepped for slab; constructed exterior wall; constructed framing; set trusses and roof sheathing.	LB Robinson	Mar 1987- Aug 1987
Strip Mall - West Carrollton Installed footer forms; tied rebar; poured footers; installed forms for walls; poured walls; prepped for slab; formed sidewalks and approaches; poured walks and approach; formed and poured piers for lighting.	LB Robinson	Aug 1987- Feb 1988
Meadowbrook Country Club Set forms for footers and poured footers; set forms for walls and poured walls; constructed wall framing; hung and finished drywall; poured and formed curbs and walks.	LB Robinson	Mar 1988- Aug 1988
St. Luke School, Beavercreek Laid out for foundation; constructed forms for footers; tied rebar; poured footers; installed forms for walls; poured walls; set door jambs.	LB Robinson	Aug 1988- Mar 1989
University of Dayton Student Store Installed footers and foundation walls; poured sidewalks; constructed walls; constructed roof framing; hung drywall.	LB Robinson	Mar 1989- Jul 1989
(continued)		
<b>Total Experience on This Page (In Months):</b>		



**Board of Building Standards**

Application for Interim Certification, Building Department Personnel

Ashley  
Last Name

Alan  
First Name

5783  
BBS Certification ID

**SECTION 8: PERSONAL HISTORY**

- 1. Have you ever been convicted of any felony, or any crime involving moral turpitude?  
 Yes  No

If you answered "Yes" please explain below:

- 2. Have you served in the U.S. armed services? (If No, skip question 3)  Yes  No
- 3. If YES, were you discharged under honorable conditions?  Yes  No

If you answered "No" please explain below:

**SECTION 9: CERTIFICATION**

I certify the information contained in this application is true and complete, and I understand that providing false information may be grounds for not granting certification or for immediate termination of certification at any point in the future, if granted. I authorize the investigation of all statements contained herein and release all parties from all liability for any damage that may result from furnishing the same to Ohio Board of Building Standards. Falsification is a violation of section 2921.13 of the Ohio Revised Code and is punishable as a misdemeanor of the first degree.

Signature of Applicant: 

Subscribed and duly sworn before me according to law, by the above named applicant this day 29th of August in the year 2022 at Montgomery Dayton, Pa. County of Montgomery and State of \_\_\_\_\_

Notary Public: 

**ERIK S COLLINS**  
Notary Public - State of Ohio  
Commission Expires Dec 21, 2026

**File Attachments for Item:**

C-2 Brinker, Jason ESI

Certification ID# 8936

Current certifications- none

Brinker

Jason

*Last Name*

*First Name*

*BBS Certification ID*

**SECTION 1: CHECK INTERIM CERTIFICATION(S) BEING REQUESTED**

<input type="checkbox"/> Building Official	<input type="checkbox"/> Master Plans Examiner	<input type="checkbox"/> Building Inspector	<input checked="" type="checkbox"/> Electrical Safety Inspector	<input type="checkbox"/> Fire Protection Inspector
<input type="checkbox"/> Building Plans Examiner	<input type="checkbox"/> Plumbing Plans Examiner	<input type="checkbox"/> Mechanical Plans Examiner	<input type="checkbox"/> Electrical Plans Examiner	<input type="checkbox"/> Fire Protection Plans Examiner
	<input type="checkbox"/> Plumbing Inspector	<input type="checkbox"/> Mechanical Inspector	<input type="checkbox"/> Non-Residential Industrial Unit Inspector	

**SECTION 2: LIST ANY OHIO LICENSE, CERTIFICATE, OR REGISTRATION HELD**

(Mark "T" If Trainee)

Description		Certificate Number	Date Received
Architectural Registration			
P.E. Registration			
Res	Non-Res		
<input type="checkbox"/>	<input type="checkbox"/>	Building Official Certification	
<input type="checkbox"/>	<input type="checkbox"/>	Plans Examiner Certification	
<input type="checkbox"/>	<input type="checkbox"/>	Building Inspector Certification	
<input type="checkbox"/>	<input type="checkbox"/>	Mechanical Inspector Certification	
Building Plans Examiner Certification			
Mechanical Plans Examiner Certification			
Fire Protection Plans Examiner Certification			
Electrical Plans Examiner Certification			
Plumbing Plans Examiner Certification			
Fire Protection Inspector Certification			
Electrical Safety Inspector Certification			
Plumbing Inspector Certification			
Fire Safety Inspector Certification			
Fire Protection System Designer Certification			
Medical Gas Piping Inspector Certification			

Brinker

Jason

*Last Name*

*First Name*

*BBS Certification ID*

**SECTION 3: EMPLOYMENT/EDUCATION**

Formal Education	Date Graduated
Reading High School	1996
Related Vocational or Technical Training	Years' Experience
Scarlet Oaks, Commercial Residential Electricity	2
Independent Electrical Contractors of Cincinnati Apprenticeship	4
U.S. Military construction experience (MOS or other designation):	Years' Experience
N/A	
Place of Employment:	Years' Employed

**SECTION 4: APPLICANTS REQUESTING MEDICAL GAS INSPECTOR CERTIFICATION**

*Attach proof of certification by an ASSE recognized third-party certifier in accordance with ASSE standard 6020.*

**SECTION 5: OBC BUILDING INSPECTION EXPERIENCE PERFORMED FOR A BBS CERTIFIED BUILDING DEPARTMENT**

BBS Certified Building Department	BBS Certified Position/Title	Duties	Date of Service, Length of Time (MM/DD/YY)

Brinker

Jason

*Last Name*

*First Name*

*BBS Certification ID*

**SECTION 6: ELECTRICAL SAFETY INSPECTOR (ESI) - SPECIFIC EXPERIENCE QUALIFICATIONS**

Applicants for Electrical Safety Inspector Only Must Complete This Item

Section 3783 of the Ohio Revised Code specifies that an applicant for a Certificate of Competency as an Electrical Safety Inspector must meet one of the following to qualify to take required examination. Please check the qualification that applies:

1.  Have been a journeyman electrician or equivalent for four years, two of which were as an electrician foreman, and have had two years' experience as a building department electrical inspector trainee;
2.  Have been a journeyman electrician or equivalent for four years and have had three years' experience as a building department electrical inspector trainee;
3.  Have had for four years' experience as a building department electrical inspector trainee;
4.  Have been a journeyman electrician or equivalent for six years;
5.  Am a graduate electrical engineer and registered in the State of Ohio. Registration number: \_\_\_\_\_
6.  Applicant authorizes all testing organizations including ICC to provide test results to the BBS.

**SECTION 7: EXPERIENCE (DO NOT SUBSTITUTE WITH OTHER RESUMES).**

Refer to Experience Requirements Listed in O.A.C. 4101:7-3-01 and O.R.C. 3783

Below, list the specific projects you worked on, and the specific work you performed, your typical duties for each project, and dates of this work. You must demonstrate that you have the required number of months (years) of actual, practical experience for the certification requested (see matrix).

Provide letters from certified inspectors, employers, or contractors verifying your experience. Submit copies of any certificates, diplomas, or licenses. Remove all personal information.

**SECTION 7 CONT.: EXPERIENCE**

List Each Construction Project <b>AND</b> Specific Type of Work Performed	Name of Employer, Contact, Address, Telephone Number	Project Time: From_ To _ (MM/YY)
<i>Example:</i> Children's Hospital, Toledo Structural steel work on addition	Homer Steel and Trade 125 Anytown Street My City, OH, 45454 (419)555-1212	July 2013-May 2014 (10 months)
Natorp's Retail Center Mason, OH Installed PVC conduit for branch circuits. Installed feeders for rooftop units. Installed new sub-panel. Installed switches, receptacles, and luminaires.	Trebor Electric Contractors 3860 Limerick Avenue Cincinnati, Ohio 45326 513-200-1235	2/2021-8/2021 6 months
<b>Total Experience on This Page (In Months):</b>		<b>6</b>



**Brinker**

**Jason**

*Last Name*

*First Name*

*BBS Certification ID*

List Each Construction Project <u>AND</u> Specific Type of Work Performed	Name of Employer, Contact, Address, Telephone Number	Project Time: From_ To _ (MM/YY)
<p>Natorp's 1000 Series Greenhouses Mason, OH Installed PVC conduit above and below ground for 20 greenhouses. Pulled wire. Installed PVC boxes and GFCI outlets for blower motors. Installed thermostats for louvers to regulate temperature and airflow.</p>	<p>Trebor Electric Contractors 3860 Limerick Avenue Cincinnati, Ohio 45326 513-200-1235</p>	<p>8/2021-10/2021 2 months</p>
<p>Cedar Oaks Drug and Alcohol Rehabilitation Center Oregonia, OH Installed five back-up generators for detox center, dining hall, and dormitories. Installed security lighting over the 100 acre complex. Repaired existing electric as needed.</p>		<p>10/2021-9/2022 11 months</p>
<p>Buffalo Wild Wings Beechmont, Cincinnati, OH Installed MC cable and EMT conduit for wall roughs. Installed PVC conduit for slab rough. Installed 4 inch PVC conduit and switch gear. Installed EMT and pulled wire for branch circuits. Supervised crew 7 electricians.</p>	<p>Gilkey Electric 607 Redna Terrace Cincinnati, Ohio 45215</p>	<p>6-2013-12/2013 6 months</p>
<p>Capital Grill Rookwood, Cincinnati, OH Supervised 6 electricians. PVC conduit for slab rough and feeders. Installed CT cabinet and switch gear. Wall rough-in with MC cable and EMT conduit. Installed conduit and wire for rooftop units and refrigeration equipment. Installed 2x4 luminaires in drop ceiling. Hooked up kitchen equipment. Installed receptacles, switches and cover plates.</p>		<p>3/2014-10/2014 7 months</p>
<p><b>Total Experience on This Page (In Months):</b></p>		<p><b>26</b></p>

**Brinker**

**Jason**

*Last Name*

*First Name*

*BBS Certification ID*

<b>List Each Construction Project <u>AND</u> Specific Type of Work Performed</b>	<b>Name of Employer, Contact, Address, Telephone Number</b>	<b>Project Time: From_ To _ (MM/YY)</b>
<p>Garfield Towers Cincinnati, OH Replaced all existing sub-panels and pulled branch circuits for new heating/cooling through-wall units in 56 unit apartment building.</p>	<p>DRH Electric Mason, OH 513-652-1031</p>	<p>04/2011–11/2011 7 months</p>
<p>Environmental Protection Agency Cincinnati, OH Demolition of existing electric on floors 1 through 6. Installed 277 volt lighting, conduit, and receptacles per plans. Installed buck boost transformers and circuits for new lab equipment.</p>	<p>Queen City Electric 4015 Cherry Street Cincinnati, OH 513-591-2600</p>	<p>12/2007-1/2009 24 months</p>
<p>Middletown Senior Center Middletown, OH Installed luminaires, switches and receptacles. Final hook-ups for commercial cooking equipment. Pulled wire for and installed parking lot lighting. Installed exit and emergency lighting.</p>		<p>9/2007-12/2007 3 months</p>
<p>Dupree House Cincinnati, OH 30 Unit Condominium Complex. Installed MC cable and conduit per plans. Installed panels for each unit. Installed receptacles, switches, and luminaires.</p>	<p>TMI Electrical Contractors 423 W. Wyoming Ave Cincinnati, OH 513-821-9900</p>	<p>5/2006-9/2007 15 months</p>
<b>Total Experience on This Page (In Months):</b>		<b>49</b>

Brinker

Jason

Last Name

First Name

BBS Certification ID

SECTION 8: PERSONAL HISTORY

1. Have you ever been convicted of any felony, or any crime involving moral turpitude?

Yes  No

If you answered "Yes" please explain below:

2. Have you served in the U.S. armed services? (If No, skip question 3)

Yes  No

3. If YES, were you discharged under honorable conditions?

Yes  No

If you answered "No" please explain below:

N/A

SECTION 9: CERTIFICATION

I certify the information contained in this application is true and complete, and I understand that providing false information may be grounds for not granting certification or for immediate termination of certification at any point in the future, if granted. I authorize the investigation of all statements contained herein and release all parties from all liability for any damage that may result from furnishing the same to Ohio Board of Building Standards. Falsification is a violation of section 2921.13 of the Ohio Revised Code and is punishable as a misdemeanor of the first degree.

Signature of Applicant:

*Jason Brinker*

Subscribed and duly sworn before me according to law, by the above named applicant this day 4<sup>th</sup> of September in the year 2022 at Hillsboro, County of Highland and State of Ohio.

Notary Public:

*Rebecca Wiget*



REBECCA WIGET  
Notary Public  
State of Ohio  
My Comm. Expires  
March 13, 2027

**File Attachments for Item:**

C-3 Brown, Kenneth BI

Certification ID# 8937

Current certifications- none

Brown  
Last Name

Kevin  
First Name

\_\_\_\_\_  
BBS Certification ID

**SECTION 1: CHECK INTERIM CERTIFICATION(S) BEING REQUESTED**

<input type="checkbox"/> Building Official	<input type="checkbox"/> Master Plans Examiner	<input checked="" type="checkbox"/> Building Inspector	<input type="checkbox"/> Electrical Safety Inspector	<input type="checkbox"/> Fire Protection Inspector
<input type="checkbox"/> Building Plans Examiner	<input type="checkbox"/> Plumbing Plans Examiner	<input type="checkbox"/> Mechanical Plans Examiner	<input type="checkbox"/> Electrical Plans Examiner	<input type="checkbox"/> Fire Protection Plans Examiner
	<input type="checkbox"/> Plumbing Inspector	<input type="checkbox"/> Mechanical Inspector	<input type="checkbox"/> Non-Residential Industrial Unit Inspector	

**SECTION 2: LIST ANY OHIO LICENSE, CERTIFICATE, OR REGISTRATION HELD**

(Mark "T" If Trainee)

Description			Certificate Number	Date Received
Architectural Registration				
P.E. Registration				
Res	Non-Res			
<input type="checkbox"/>	<input type="checkbox"/>	Building Official Certification		
<input type="checkbox"/>	<input type="checkbox"/>	Plans Examiner Certification		
<input type="checkbox"/>	<input type="checkbox"/>	Building Inspector Certification		
<input type="checkbox"/>	<input type="checkbox"/>	Mechanical Inspector Certification		
Building Plans Examiner Certification				
Mechanical Plans Examiner Certification				
Fire Protection Plans Examiner Certification				
Electrical Plans Examiner Certification				
Plumbing Plans Examiner Certification				
Fire Protection Inspector Certification				
Electrical Safety Inspector Certification				
Plumbing Inspector Certification				
Fire Safety Inspector Certification				
Fire Protection System Designer Certification				
Medical Gas Piping Inspector Certification				

Brown  
Last Name

Kenneth  
First Name

\_\_\_\_\_  
BBS Certification ID

**SECTION 3: EMPLOYMENT/EDUCATION**

Formal Education	Date Graduated
Western Brown High School MT, Ohio	May 31, 1992
Related Vocational or Technical Training	Years' Experience
Southern Hills Career Center 1500 hrs. CAD/CADD	2 yrs May 8, 1992
U.S. Military construction experience (MOS or other designation):	Years' Experience
Place of Employment:	Years' Employed
CLERMONT COUNTY Park District, Construction Supervisor	April 2016 - current 4 yrs

**SECTION 4: APPLICANTS REQUESTING MEDICAL GAS INSPECTOR CERTIFICATION**

*Attach proof of certification by an ASSE recognized third-party certifier in accordance with ASSE standard 6020.*

**SECTION 5: OBC BUILDING INSPECTION EXPERIENCE PERFORMED FOR A BBS CERTIFIED BUILDING DEPARTMENT**

BBS Certified Building Department	BBS Certified Position/Title	Duties	Date of Service, Length of Time (MM/DD/YY)

Brown  
Last Name

Kenneth  
First Name

\_\_\_\_\_  
BBS Certification ID

**SECTION 6: ELECTRICAL SAFETY INSPECTOR (ESI) - SPECIFIC EXPERIENCE QUALIFICATIONS**

Applicants for Electrical Safety Inspector Only Must Complete This Item

Section 3783 of the Ohio Revised Code specifies that an applicant for a Certificate of Competency as an Electrical Safety Inspector must meet one of the following to qualify to take required examination. Please check the qualification that applies:

1.  Have been a journeyman electrician or equivalent for four years, two of which were as an electrician foreman, and have had two years' experience as a building department electrical inspector trainee;
2.  Have been a journeyman electrician or equivalent for four years and have had three years' experience as a building department electrical inspector trainee;
3.  Have had for four years' experience as a building department electrical inspector trainee;
4.  Have been a journeyman electrician or equivalent for six years;
5.  Am a graduate electrical engineer and registered in the State of Ohio. Registration number: \_\_\_\_\_
6.  Applicant authorizes all testing organizations including ICC to provide test results to the BBS.

**SECTION 7: EXPERIENCE (DO NOT SUBSTITUTE WITH OTHER RESUMES)**

Refer to Experience Requirements Listed in O.A.C. 4101:7-3-01 and O.R.C. 3783

Below, list the specific projects you worked on, and the specific work you performed, your typical duties for each project, and dates of this work. You **must** demonstrate that you have the required number of months (years) of actual, practical experience for the certification requested (see matrix).

Provide letters from certified inspectors, employers, or contractors verifying your experience. Submit copies of any certificates, diplomas, or licenses. Remove all personal information.

**SECTION 7 CONT.: EXPERIENCE**

List Each Construction Project <u>AND</u> Specific Type of Work Performed	Name of Employer, Contact, Address, Telephone Number	Project Time: From_ To_ (MM/YY)
<i>Example:</i> Children's Hospital, Toledo Structural steel work on addition	Homer Steel and Trade 125 Anytown Street My City, OH, 45454 (419)555-1212	July 2013-May 2014 (10 months)
<b>Total Experience on This Page (In Months):</b>		

**Board of Building Standards**

Application for Interim Certification, Building Department Personnel

BROWN

Last Name

Kenneth

First Name

BBS Certification ID

List Each Construction Project AND Specific Type of Work Performed	Name of Employer, Contact, Address, Telephone Number	Project Time: From To (MM/YY)
Greater Cincinnati area, Rough Framing, carpentry, Wood construction of multiple single family homes per year.	Quince Construction OWNER retired and moved to Florida phone # 513-526-0127 WILLIAM GRIFFIN	5/1993 - 7/2000
Greater Cincinnati area Rough Framing Wood construction SUPERVISOR/Crew leader OF MULTIPLE single family homes per year.	Quince Construction OWNER retired & moved to Florida 513-520-0127 William Griffin	86 months 8/2000 - 4/2012
General building maintenance on 8 single family homes, Garages, sheds, barns, office building, and a Green house	Residential Concepts Inc. 4013 Tolgus Rd Batavia OH 45103 513-724-0094	144 months 4/2012 - 6/2018
General building maintenance/carpentry on multiple park structures, shelters, restrooms, rental facilities and offices.	Chelmont County Park District 2150 ST RT 50 Batavia, OH 45103. 513-732-2977	72 months 6/2018 - current  48+ months
Total Experience on This Page (In Months):		350



BROWN  
Last Name

KENNETH  
First Name

\_\_\_\_\_  
BBS Certification ID

**SECTION 8: PERSONAL HISTORY**

1. Have you ever been convicted of any felony, or any crime involving moral turpitude?

Yes  No

If you answered "Yes" please explain below:

2. Have you served in the U.S. armed services? (If No, skip question 3)

Yes  No

3. If YES, were you discharged under honorable conditions?

Yes  No

If you answered "No" please explain below:

**SECTION 9: CERTIFICATION**

*I certify the information contained in this application is true and complete, and I understand that providing false information may be grounds for not granting certification or for immediate termination of certification at any point in the future, if granted. I authorize the investigation of all statements contained herein and release all parties from all liability for any damage that may result from furnishing the same to Ohio Board of Building Standards. Falsification is a violation of section 2921.13 of the Ohio Revised Code and is punishable as a misdemeanor of the first degree.*

Signature of Applicant: *Kenneth Brown*

Subscribed and duly sworn before me according to law, by the above named applicant this day 9 of September in the year 2022 at 4:00pm Williamsburg, County of Brown and State of Ohio.

Notary Public: *Marilyn Lawrence*



William Griffin woriffin306@gmail.com

William Griffin  
Montgomery County Inspector

Date: Sep 5, 2022 at 2:15 PM

To: kenbrown6405@gmail.com

To whom it may concern:

Ken Brown worked for me for about twenty years. In that time he went from laborer to a very accomplished crew leader; a position he fulfilled not only as lead carpenter but crew leader as well. There was no job too difficult.

If I had had twelve more of Mr. Brown I could have retired sooner.

I highly recommend Mr. Brown as a highly competent and reliable employee.

Sincerely,

William Griffin

President/Owner

Quince Construction Inc.



4073 Tollgate Road  
Batavia, Ohio 45103  
513-724-0094; Fax: 513-724-0786

September 6, 2022

Clermont County Building Inspection  
2275 Bauer Rd.  
Batavia, OH 45103

RE: Letter of Recommendation –  
Ken Brown

To Whom It May Concern,

Ken Brown was employed for our company, April 9, 2012 – June 22, 2018. During his employment, Ken performed general maintenance duties, both skilled and unskilled, for our three adult day program locations and our six residential group homes. Ken performed repairs or installations on simple electrical equipment, plumbing fixtures, and carpentry. He also assisted other tradesmen on larger projects. He performed simple repairs on building interiors, exteriors, and equipment as well.

I have always been consistently impressed by Ken's work ethic and attitude towards his work and his performance on the job. He is one to do the job correctly and not cut corners. He is trustworthy and hardworking, and just a great guy with a positive personality and outlook.

I recommend him for employment without reservation. Please let me know if you need further information.

A handwritten signature in blue ink, appearing to read "Lindsey Jones". The signature is fluid and cursive.

Lindsey Jones, MBA, BSc  
Business Administrator  
Residential Concepts, Inc.

9/6/2022

Clermont County Permit Central

2275 Bauer Road

Batavia, OH 45103

To Whom It May Concern:

It is with great pleasure that I am recommending Ken Brown to you. I am the Operations Superintendent for Clermont County Park District and I have supervised Ken, who held the position of Construction specialist from June 2018 until now.

Ken would be a great asset to Clermont County Permit Central.

Ken has work on numerous new construction, and remodeling projects since being with the Park District, that includes concrete and footing work, site work, framing, electrical, and finish carpentry.

If you have any further questions, feel free to contact me at 513-439-7113, and I will be happy to answer any question you have.

Sincerely

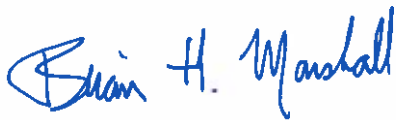

Brian H. Marshall

Operations Superintendent

Western Brown Local Schools

# Western Brown High School

Mount Orab, Ohio

BROWN COUNTY

This Certifies That

**Kenny R. Brown**

has completed the Program of Study prescribed for Graduation from this School  
and is therefore awarded this

## Diploma

Given this thirty-first day of May, nineteen hundred and ninety-two.

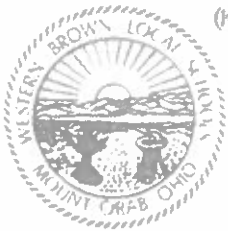

*Walter Jackson*  
Principal

*Ben S. Wall*  
President of Board

*Denny Dunlap*  
Secretary Board of Education

*Jim Rosendahl*  
Superintendent

OHIO DEPARTMENT OF EDUCATION  
DIVISION OF VOCATIONAL AND CAREER EDUCATION

**Certificate of Program Completion**

*This certifies that*

KENNY R. BROWN

*has satisfactorily completed 1500 hours of vocational instruction in*

CARPENTRY

*In testimony thereto, this certificate is issued by the Ohio Department of Education,  
Division of Vocational and Career Education, in conjunction with*

SOUTHERN HILLS CAREER CENTER

MAY 28, 1992

*Ted Sanders*

Superintendent of Public Instruction

*William J. Phillipis*

Assistant Superintendent of Public Instruction

*James R. Phillips III*

Director, Division of Vocational and Career Education



*Robert H. Sherry*

Local Superintendent

*Rich Scott*

*James R. Phillips III*

Southern Hills Career Center



### Vocational Certificate of Completion

This Certifies that

KENNY R. BROWN

has successfully completed 2 year(s) of a 2 year state approved vocational training program in the area of

CARPENTRY

Teachers James P. Brown  
Paul M. Johnson  
Gregory Hart

Supervisor \_\_\_\_\_  
Director Rick Scott  
Superintendent Paul Blawie

**U.S. Grant Joint Vocational School**  
**ADULT EDUCATION DIVISION**

**Certificate of Completion**

Kenny Brown

*has completed* 36 *hours of instruction in*  
Industrial Electrical

  
Superintendent Of Schools

December 19, 1991  
Date

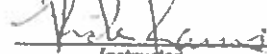
  
Director  
  
Instructor



# FOLEY-BELSAW INSTITUTE

A Division of Foley-Belsaw Company

*On recommendation of the Faculty*

**KENNETH R BROWN**

*is awarded this*

## DIPLOMA

*in recognition of satisfactory completion of the prescribed course in*  
**HOME INSPECTION**



*In witness whereof, the seal of the corporation  
is hereby affixed.*

*Walter M. Ringo, Jr.*

DIRECTOR

*George W. White*

PRESIDENT

GRADUATION DATE: AUGUST 1, 2000

**Certificate  
Of  
Achievement**

**This is to Certify**

**Kenny Brown**

*has successfully completed an adult education course*

With a total of 93 of 96 hours in the field of

**Beginning HVAC (Heating Ventilation & Air Conditioning)**

Awarded March 11 2011

  
SUPERINTENDENT

  
INSTRUCTOR

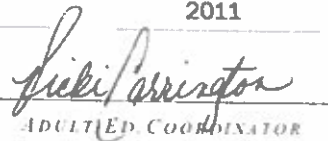
  
ADULT ED. COORDINATOR

**U.S. Grant Joint Vocational School**  
**ADULT EDUCATION DIVISION**  
**Certificate of Completion**

Kenny Brown

has completed 36 hours of instruction in

Residential Electrical

Kenneth D. Morrison  
Superintendent Of Schools

James J. [Signature]  
Director

Oct. 31, 1991  
Date

[Signature]  
Instructor

11-10-1991 10:00 AM

**File Attachments for Item:**

C-4 Collins, Thomas PI, PPE

Certification ID# 8931

Current certifications- none

Collins  
Last Name

THOMAS  
First Name

\_\_\_\_\_  
BBS Certification ID

**SECTION 1: CHECK INTERIM CERTIFICATION(S) BEING REQUESTED**

<input type="checkbox"/> Building Official	<input type="checkbox"/> Master Plans Examiner	<input type="checkbox"/> Building Inspector	<input type="checkbox"/> Electrical Safety Inspector	<input type="checkbox"/> Fire Protection Inspector
<input type="checkbox"/> Building Plans Examiner	<input checked="" type="checkbox"/> Plumbing Plans Examiner	<input type="checkbox"/> Mechanical Plans Examiner	<input type="checkbox"/> Electrical Plans Examiner	<input type="checkbox"/> Fire Protection Plans Examiner
	<input checked="" type="checkbox"/> Plumbing Inspector	<input type="checkbox"/> Mechanical Inspector	<input type="checkbox"/> Non-Residential Industrial Unit Inspector	

**SECTION 2: LIST ANY OHIO LICENSE, CERTIFICATE, OR REGISTRATION HELD**

(Mark "T" If Trainee)

Description		Certificate Number	Date Received
Architectural Registration			
P.E. Registration			
Res	Non-Res		
<input type="checkbox"/>	<input type="checkbox"/>	Building Official Certification	
<input type="checkbox"/>	<input type="checkbox"/>	Plans Examiner Certification	
<input type="checkbox"/>	<input type="checkbox"/>	Building Inspector Certification	
<input type="checkbox"/>	<input type="checkbox"/>	Mechanical Inspector Certification	
Building Plans Examiner Certification			
Mechanical Plans Examiner Certification			
Fire Protection Plans Examiner Certification			
Electrical Plans Examiner Certification			
Plumbing Plans Examiner Certification			
Fire Protection Inspector Certification			
Electrical Safety Inspector Certification			
Plumbing Inspector Certification			
Fire Safety Inspector Certification			
Fire Protection System Designer Certification			
Medical Gas Piping Inspector Certification			

Collins  
Last Name

THOMAS  
First Name

\_\_\_\_\_  
BBS Certification ID

**SECTION 3: EMPLOYMENT/EDUCATION**

Formal Education	Date Graduated
WILLOUGHBY EASTLAKE SCHOOLS	1983
Related Vocational or Technical Training	Years' Experience
PLUMBERS LOCAL UNION # 55 5 YR. APPRENTICESHIP	5 YR.
U.S. Military construction experience (MOS or other designation):	Years' Experience
Place of Employment:	Years' Employed
JOURNEYMAN PLUMBER LOCAL UNION # 55	30 YRS

**SECTION 4: APPLICANTS REQUESTING MEDICAL GAS INSPECTOR CERTIFICATION**

*Attach proof of certification by an ASSE recognized third-party certifier in accordance with ASSE standard 6020.*

**SECTION 5: OBC BUILDING INSPECTION EXPERIENCE PERFORMED FOR A BBS CERTIFIED BUILDING DEPARTMENT**

BBS Certified Building Department	BBS Certified Position/Title	Duties	Date of Service, Length of Time (MM/DD/YY)

Collins  
Last Name

THOMAS  
First Name

\_\_\_\_\_  
BBS Certification ID

**SECTION 6: ELECTRICAL SAFETY INSPECTOR (ESI) - SPECIFIC EXPERIENCE QUALIFICATIONS**

Applicants for Electrical Safety Inspector Only Must Complete This Item

Section 3783 of the Ohio Revised Code specifies that an applicant for a Certificate of Competency as an Electrical Safety Inspector must meet on of the following to qualify to take required examination. Please check the qualification that applies:

1.  Have been a journeyman electrician or equivalent for four years, two of which were as an electrician foreman, and have had two years' experience as a building department electrical inspector trainee;
2.  Have been a journeyman electrician or equivalent for four years and have had three years' experience as a building department electrical inspector trainee;
3.  Have had for four years' experience as a building department electrical inspector trainee;
4.  Have been a journeyman electrician or equivalent for six years;
5.  Am a graduate electrical engineer and registered in the State of Ohio. Registration number: \_\_\_\_\_
6.  Applicant authorizes all testing organizations including ICC to provide test results to the BBS.

**SECTION 7: EXPERIENCE (DO NOT SUBSTITUTE WITH OTHER RESUMES).**

Refer to Experience Requirements Listed in O.A.C. 4101:7-3-01 and O.R.C. 3783

Below, list the specific projects you worked on, and the specific work you performed, your typical duties for each project, and dates of this work. You must demonstrate that you have the required number of months (years) of actual, practical experience for the certification requested (see matrix).

Provide letters from certified inspectors, employers, or contractors verifying your experience. Submit copies of any certificates, diplomas, or licenses. Remove all personal information.

List Each Construction Project AND Specific Type of Work Performed	Name of Employer, Contact, Address, Telephone Number	Project Time: From_ To _ (MM/YY)
<p>Example: Children's Hospital, Toledo Structural steel work on addition</p>	<p>Homer Steel and Trade 125 Anytown Street My City, OH, 45454 (419)555-1212</p>	<p>July 2013-May 2014 (10 months)</p>
<p>MULTIPLE PROJECTS INC. HOSPITALS - GROCERY STORES COMMERCIAL OFFICE BUDGS.</p>	<p>NEPTUNE PLUMBING 23860 MILES RD BEDFORD HTS OH 216-475-9100</p>	<p>AUG 1993 - 2007</p>
<p>Total Experience on This Page (In Months):</p>		

Collins  
Last Name

Thomas  
First Name

\_\_\_\_\_  
BBS Certification ID

SECTION 7 CONT.: EXPERIENCE

List Each Construction Project AND Specific Type of Work Performed	Name of Employer, Contact, Address, Telephone Number	Project Time: From_ To _ (MM/YY)
<p>MULTIPLE PROJECTS INC. CLEVELAND - CLINIC - UH HOSPITAL</p>	<p>RELMEC MECH. LLC 4975 HAMILTON AVE CLEV. OH 44114  216-391-1030</p>	<p>2007 - 2017</p>
<p>MULTIPLE PROJECTS INCLUDING RESTAURANT SCHOOLS, RESIDENTIAL HOMES</p>	<p>ADVANCED MECH. LLC 37960 DEPOT ST WILLOUGHBY OH 440-957-7400</p>	
<p>Total Experience on This Page (In Months):</p>		



Collins  
Last Name

THOMAS  
First Name

\_\_\_\_\_  
BBS Certification ID

**SECTION 8: PERSONAL HISTORY**

1. Have you ever been convicted of any felony, or any crime involving moral turpitude?

Yes  No

If you answered "Yes" please explain below:

2. Have you served in the U.S. armed services? (If No, skip question 3)

Yes  No

3. If YES, were you discharged under honorable conditions?

Yes  No

If you answered "No" please explain below:

**SECTION 9: CERTIFICATION**

I certify the information contained in this application is true and complete, and I understand that providing false information may be grounds for not granting certification or for immediate termination of certification at any point in the future, if granted. I authorize the investigation of all statements contained herein and release all parties from all liability for any damage that may result from furnishing the same to Ohio Board of Building Standards. Falsification is a violation of section 2921.13 of the Ohio Revised Code and is punishable as a misdemeanor of the first degree.

Signature of Applicant: 

Subscribed and duly sworn before me according to law, by the above named applicant this day 11 of September in the year 2022 at 7:00 PM, County of Lake and State of Ohio.

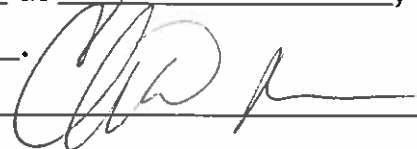
Notary Public: 

SEAL

GIA RAFFAELLI  
Notary Public, State of Ohio  
Recorded in Lake County  
My commission expires 2-22-2023



**Department  
of Commerce**

Division of Industrial Compliance  
Ohio Construction Industry  
Licensing Board O.C.I.L.B.

Mike DeWine  
Sheryl Maxfield

THOMAS P COLLINS

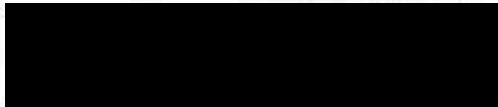

Mike DeWine Governor	<b>Plumbing CONTRACTOR'S LICENSE</b>	Sheryl Maxfield Director
Ohio License # 49326		Expiration Date: 01/06/2025
<b>THOMAS P COLLINS</b>		
<b>ADVANCED MECHANICAL CONTRACTORS LLC</b>		
<b>EMPLOYEE</b>		
<i>Carol Ross</i>		<i>William Koester</i>
Carol A. Ross Board Secretary		William Koester Administrative Chairperson

This is YOUR license. Plan Approvals obtained with YOUR license and posting of YOUR license indicates that YOU and YOUR liability insurance are assuming all responsibility for any projects performed under this license.

Mike DeWine Governor	<b>Plumbing CONTRACTOR'S LICENSE</b>	Sheryl Maxfield Director
<b>LICENSE MUST BE POSTED ON JOB SITE</b>	<b>THOMAS P COLLINS</b>	<b>LICENSE MUST BE POSTED ON JOB SITE</b>
	<b>ADVANCED MECHANICAL CONTRACTORS LLC</b>	
	<b>EMPLOYEE</b>	
	Ohio License# <b>49326</b>	
	Expiration Date: <b>January 06, 2025</b>	
<i>Carol Ross</i>		<i>William Koester</i>
Carol A. Ross Board Secretary		William Koester Administrative Chairperson

Any changes in information must be submitted within 30 days to:

**Bureau of Testing & Registration  
PO BOX 529  
Reynoldsburg, Ohio 43068  
614-752-7126  
614-995-4206 (fax)  
webfmtr@com.state.oh.us**

This license shall be carried on your person while performing the listed activities.

**State of Ohio  
Department of Commerce  
Division of State Fire Marshal  
FIRE PROTECTION LICENSE  
THOMAS P COLLINS  
54.18.3416  
Expiration Date: 01/02/2023**

Signature \_\_\_\_\_  
This card shall be on your person while performing listed activities.



**Ohio Department of Commerce  
Division of State Fire Marshal  
Bureau of Testing & Registration  
8895 E Main Street, PO Box 529  
Reynoldsburg, Ohio 43068**

**THOMAS P COLLINS**

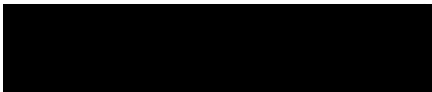

**File Attachments for Item:**

C-5 Hurt, Steven BI, RBI

Certification ID# 8939

Current certifications- none

Hurt  
Last Name

Steven  
First Name

\_\_\_\_\_  
BBS Certification ID

**SECTION 1: CHECK INTERIM CERTIFICATION(S) BEING REQUESTED**

<input checked="" type="checkbox"/> Building Official	<input type="checkbox"/> Master Plans Examiner	<input checked="" type="checkbox"/> Building Inspector	<input type="checkbox"/> Electrical Safety Inspector	<input type="checkbox"/> Fire Protection Inspector
<input type="checkbox"/> Building Plans Examiner	<input type="checkbox"/> Plumbing Plans Examiner	<input type="checkbox"/> Mechanical Plans Examiner	<input type="checkbox"/> Electrical Plans Examiner	<input type="checkbox"/> Fire Protection Plans Examiner
	<input type="checkbox"/> Plumbing Inspector	<input type="checkbox"/> Mechanical Inspector	<input type="checkbox"/> Non-Residential Industrial Unit Inspector	

**SECTION 2: LIST ANY OHIO LICENSE, CERTIFICATE, OR REGISTRATION HELD**

(Mark "T" if Trainee)

Description		Certificate Number	Date Received
Architectural Registration			
P.E. Registration			
Res	Non-Res		
<input type="checkbox"/>	<input type="checkbox"/>	Building Official Certification	
<input type="checkbox"/>	<input type="checkbox"/>	Plans Examiner Certification	
<input type="checkbox"/>	<input type="checkbox"/>	Building Inspector Certification	
<input type="checkbox"/>	<input type="checkbox"/>	Mechanical Inspector Certification	
Building Plans Examiner Certification			
Mechanical Plans Examiner Certification			
Fire Protection Plans Examiner Certification			
Electrical Plans Examiner Certification			
Plumbing Plans Examiner Certification			
Fire Protection Inspector Certification			
Electrical Safety Inspector Certification			
Plumbing Inspector Certification			
Fire Safety Inspector Certification			
Fire Protection System Designer Certification			
Medical Gas Piping Inspector Certification			

Hurt  
Last Name

Steven  
First Name

\_\_\_\_\_  
BBS Certification ID

**SECTION 3: EMPLOYMENT/EDUCATION**

Formal Education	Date Graduated
Vandercook Lake High School	1987
Jackson Comm College / Ohio State Marion	attended
Related Vocational or Technical Training	Years' Experience
OSHA 10/30hr	3
Bibbers exchange certified superintendent	
U.S. Military construction experience (MOS or other designation):	Years' Experience
/	/
Place of Employment:	Years' Employed
Rockford Homes	3
MCR Services	11

**SECTION 4: APPLICANTS REQUESTING MEDICAL GAS INSPECTOR CERTIFICATION**

**Attach proof** of certification by an ASSE recognized third-party certifier in accordance with ASSE standard 6020.

**SECTION 5: OBC BUILDING INSPECTION EXPERIENCE PERFORMED FOR A BBS CERTIFIED BUILDING DEPARTMENT**

BBS Certified Building Department	BBS Certified Position/Title	Duties	Date of Service, Length of Time (MM/DD/YY)
/			

Hurt  
Last Name

Steven  
First Name

\_\_\_\_\_  
BBS Certification ID

**SECTION 6: ELECTRICAL SAFETY INSPECTOR (ESI) - SPECIFIC EXPERIENCE QUALIFICATIONS**

Applicants for Electrical Safety Inspector Only Must Complete This Item

Section 3783 of the Ohio Revised Code specifies that an applicant for a Certificate of Competency as an Electrical Safety Inspector must meet one of the following to qualify to take required examination. Please check the qualification that applies:

1.  Have been a journeyman electrician or equivalent for four years, two of which were as an electrician foreman, and have had two years' experience as a building department electrical inspector trainee;
2.  Have been a journeyman electrician or equivalent for four years and have had three years' experience as a building department electrical inspector trainee;
3.  Have had for four years' experience as a building department electrical inspector trainee;
4.  Have been a journeyman electrician or equivalent for six years;
5.  Am a graduate electrical engineer and registered in the State of Ohio. Registration number: \_\_\_\_\_
6.  Applicant authorizes all testing organizations including ICC to provide test results to the BBS.

**SECTION 7: EXPERIENCE (DO NOT SUBSTITUTE WITH OTHER RESUMES).**

Refer to Experience Requirements Listed in O.A.C. 4101:7-3-01 and O.R.C. 3783

Below, list the specific projects you worked on, and the specific work you performed, your typical duties for each project, and dates of this work. You **must** demonstrate that you have the required number of months (years) of actual, practical experience for the certification requested (see matrix).

Provide letters from certified inspectors, employers, or contractors verifying your experience. Submit copies of any certificates, diplomas, or licenses. Remove all personal information.

**SECTION 7 CONT.: EXPERIENCE**

List Each Construction Project <u>AND</u> Specific Type of Work Performed	Name of Employer, Contact, Address, Telephone Number	Project Time: From _ To _ (MM/YY)
<i>Example:</i> Children's Hospital, Toledo Structural steel work on addition	Homer Steel and Trade 125 Anytown Street My City, OH, 45454 (419)555-1212	July 2013-May 2014 (10 months)
Warren Harding Presidential Center Marion Ohio Site Super for general Contractor	Thomas + Marker Construction Columbus/Bellefontaine, Ohio Becca McGillis (330) 571-2609	Feb 2019 - July 2020 17
Park @ Seldom seen Site Super for GC	Thomas + Marker Construction Columbus/Bellefontaine, Ohio Becca McGillis (330) 571-2609	July 2018 - Feb 2019 6
<b>Total Experience on This Page (In Months):</b>		24 months

Hurt

Steven

Last Name

First Name

BBS Certification ID

List Each Construction Project <u>AND</u> Specific Type of Work Performed	Name of Employer, Contact, Address, Telephone Number	Project Time: From To (MM/YY)
Wesco Electric Warehouse Superintendent for General Contractor	MCR services Columbus, Ohio Kenny Westrick (614) 546-7346	1/2008 - 9/2008 (8)
Rumpke Recycling facility Superintendent for General Contractor	MCR Services " "	9/2009 - 7/2010 (10)
Community Housing Network Multi-Family Super for General Contract	MCR services " "	8/2010 - 1/2016 (16)
Sterling Distribution Warehouse Super for General Contractor	MCR services " "	2/2016 - 8/2016 (10)
Kohls Department Store Florence Kentucky Super for General Contractor	Lincoln Construction Columbus Ohio Roger Ross (614) 457-6015	2/2003 - 10/2003 (8)
Denison University including Knapp Hall Renovation Super for General Contract	Lincoln Construction Columbus Ohio Roger Ross (614) 457-6015	3/2004 - 9/2005 (15)
Total Experience on This Page (In Months):		113



Last Name

First Name

BBS Certification ID

SECTION 8: PERSONAL HISTORY

1. Have you ever been convicted of any felony, or any crime involving moral turpitude?

Yes  No

If you answered "Yes" please explain below:

2. Have you served in the U.S. armed services? (If No, skip question 3)

Yes  No

3. If YES, were you discharged under honorable conditions?

Yes  No

If you answered "No" please explain below:

Empty table for explanation of "No" answers.

SECTION 9: CERTIFICATION

I certify the information contained in this application is true and complete, and I understand that providing false information may be grounds for not granting certification or for immediate termination of certification at any point in the future, if granted. I authorize the investigation of all statements contained herein and release all parties from all liability for any damage that may result from furnishing the same to Ohio Board of Building Standards. Falsification is a violation of section 2921.13 of the Ohio Revised Code and is punishable as a misdemeanor of the first degree.

Signature of Applicant: [Handwritten Signature]

Subscribed and duly sworn before me according to law, by the above named applicant this day 13th of Sept in the year 2022 at Delaware, County of Delaware and State of Ohio.

Notary Public: [Handwritten Signature]

SEAL



# Board of Building Standards

Application for Interim Certification, Building Department Personnel

Hurt  
Last Name

Steven  
First Name

\_\_\_\_\_  
BBS Certification ID

## SECTION 1: CHECK INTERIM CERTIFICATION(S) BEING REQUESTED

<input checked="" type="checkbox"/> Res. Building Official	<input type="checkbox"/> Res. Plans Examiner	<input checked="" type="checkbox"/> Res. Building Inspector
<input type="checkbox"/>	<input type="checkbox"/> Res. Industrial Unit Inspector	<input type="checkbox"/> Res. Mechanical Inspector

## SECTION 2: LIST ANY OHIO LICENSE, CERTIFICATE, OR REGISTRATION HELD (Mark "T" If Trainee)

Description	Certificate Number	Date Received
Architectural Registration		
P.E. Registration		
Res	Non-Res	
<input type="checkbox"/>	<input type="checkbox"/>	Building Official Certification
<input type="checkbox"/>	<input type="checkbox"/>	Plans Examiner Certification
<input type="checkbox"/>	<input type="checkbox"/>	Building Inspector Certification
<input type="checkbox"/>	<input type="checkbox"/>	Mechanical Inspector Certification
Building Plans Examiner Certification		
Mechanical Plans Examiner Certification		
Fire Protection Plans Examiner Certification		
Electrical Plans Examiner Certification		
Plumbing Plans Examiner Certification		
Fire Protection Inspector Certification		
Electrical Safety Inspector Certification		
Plumbing Inspector Certification		
Fire Safety Inspector Certification		
Fire Protection System Designer Certification		
Medical Gas Piping Inspector Certification		

## Section 3: Employment/Education

a. Formal Education	Date Graduated
<u>Vandercook Lake High School</u>	<u>1987</u>
<u>Jackson Perm College / Ohio State Marion</u>	<u>attended</u>
b. Related Vocational or Technical Training	Years' Experience
<u>OSHA 10/30</u>	<u>31</u>
<u>BX certified superintendent program</u>	
c. U.S. Military construction experience (MOS or other designation):	Years' Experience
d. Place of Employment:	Years' Employed
<u>Rockford Homes</u>	<u>3</u>

# Board of Building Standards

Application for Interim Certification, Building Department Personnel

Hurt  
Last Name

Steven  
First Name

\_\_\_\_\_  
BBS Certification ID

## SECTION 4: OBC/RCO BUILDING INSPECTION EXPERIENCE PERFORMED FOR A BBS CERTIFIED BUILDING DEPARTMENT

BBS Certified Building Department	BBS Certified Position/Title	Duties	Date of Service, Length of Time (MM/DD/YY)
/			

## SECTION 5: EXPERIENCE (DO NOT SUBSTITUTE WITH OTHER RESUMES).

Refer to Experience Requirements Listed in O.A.C. 4101:7-3-01 and O.R.C. 3783

Below, list the specific projects you worked on, and the specific work you performed, your typical duties for each project, and dates of this work. You must demonstrate that you have the required number of months (years) of actual, practical experience for the certification requested (see matrix).

Provide letters from certified inspectors, employers, or contractors verifying your experience. Submit copies of any certificates, diplomas, or licenses. Remove all personal information.

List Each Construction Project AND Specific Type of Work Performed	Name of Employer, Contact, Address, Telephone Number	Project Time: From _ To _ (MM/YY)
<i>Example:</i> Children's Hospital, Toledo Structural steel work on addition	Homer Steel and Trade 125 Anytown Street My City, OH, 45454 (419)555-1212	July 2013-May 2014 (10 months)
Northstar development Superintendent of approx 10 homes	Rockford Homes Columbus Ohio	2/2021 - 8/2021
Chershire Woods development Superintendent of 6 homes	" "	2/2021 - 8/2021
The Pines development Superintendent of 30 homes	" "	2/2021 - 8/2021
Clark Shaw Homes Superintendent 24 homes	" "	6/2022 - current
<b>Total Experience on This Page (In Months):</b>		9 months

**Board of Building Standards**

Application for Interim Certification, Building Department Personnel

Hort  
Last Name

Steven  
First Name

\_\_\_\_\_  
BBS Certification ID

**SECTION 5 CONT.: EXPERIENCE**

List Each Construction Project AND Specific Type of Work Performed	Name of Employer, Contact, Address, Telephone Number	Project Time: From _ To _ (MM/YY)
Warren Harding Residential Center Site super for General Contractor	Thomas & Marker Const Columbus / Bellefontaine Becca McGillis (330) 571-2609	Feb 2019 - July 2020 (17)
Park @ Seldom Seen Site super for G.C.	Thomas & Marker Construction " "	July 2018 - Feb 2019 (7)
Wesco Electric Warehouse Site super for G.C.	MCR services Columbus Ohio Kenny Westrick (614) 546-7346	1/2008 - 9/2008 (8)
Rumple Recycling Center Super for G.C.	MCR services " "	9/2009 - 7/2010 (10)
Community Housing Network Multi-Family Site super	MCR services " "	8/2010 - 1/2016 (66)
Stirling Distribution Warehouse Paper distribution Site super for G.C.	MCR service " "	2/2016 - 8/2016 (6)
Kohls Department Store Florence, Kentucky Site Super for G.C.	Lincoln Construction Columbus, Ohio Roger Ross (614) 457-6015	2/2003 - 10/2003 (8)
Denison University Knapp Hall renovation Super for G.C.	Lincoln Construction " "	3/2004 - 9/2005 (15)
Ditch Witch Columbus Sales & service building Site Super for G.C.	MCR services	10/2008 - 4/2009 (6)
Total Experience on This Page (In Months):		143

**Board of Building Standards**

Application for Interim Certification, Building Department Personnel

Hurt

Steven

Last Name

First Name

BBS Certification ID

**SECTION 6: PERSONAL HISTORY**

- 1. Have you ever been convicted of any felony, or any crime involving moral turpitude?  Yes  No
- 2. If you answered "Yes" please explain below:
- 3. Have you served in the U.S. armed services? (If No, skip question 3)  Yes  No
- 4. If YES, were you discharged under honorable conditions?  Yes  No  
If you answered "No" please explain below:

**SECTION 7: CERTIFICATION**

I certify the information contained in this application is true and complete, and I understand that providing false information may be grounds for not granting certification or for immediate termination of certification at any point in the future, if granted. I authorize the investigation of all statements contained herein and release all parties from all liability for any damage that may result from furnishing the same to Ohio Board of Building Standards. Falsification is a violation of section 2921.13 of the Ohio Revised Code and is punishable as a misdemeanor of the first degree.

Signature of Applicant:

[Handwritten Signature]

Subscribed and duly sworn before me according to law, by the above named applicant this day 13<sup>th</sup> of 13<sup>th</sup> Sept in the year 20 22 at Adeloune, County of Delaware and State of Ohio.

Notary Public:

[Handwritten Signature]

SEAL



**File Attachments for Item:**

C-6 LaLonde, Douglas BPE

Certification ID# 1992

Current certifications- RPE, BI, RBO, MI, RMI, CBO

**Board of Building Standards**

Application for Interim Certification, Building Department Personnel

LALONOE

DOUGLAS

1992

Last Name

First Name

BBS Certification ID

**SECTION 1: CHECK INTERIM CERTIFICATION(S) BEING REQUESTED**

<input type="checkbox"/> Building Official	<input type="checkbox"/> Master Plans Examiner	<input type="checkbox"/> Building Inspector	<input type="checkbox"/> Electrical Safety Inspector	<input type="checkbox"/> Fire Protection Inspector
<input checked="" type="checkbox"/> Building Plans Examiner	<input type="checkbox"/> Plumbing Plans Examiner	<input type="checkbox"/> Mechanical Plans Examiner	<input type="checkbox"/> Electrical Plans Examiner	<input type="checkbox"/> Fire Protection Plans Examiner
	<input type="checkbox"/> Plumbing Inspector	<input type="checkbox"/> Mechanical Inspector	<input type="checkbox"/> Non-Residential Industrial Unit Inspector	

**SECTION 2: LIST ANY OHIO LICENSE, CERTIFICATE, OR REGISTRATION HELD**

(Mark "T" If Trainee)

Description		Certificate Number	Date Received
Architectural Registration			
P.E. Registration			
Res	Non-Res		
<input checked="" type="checkbox"/>	<input checked="" type="checkbox"/>	Building Official Certification <i>INT.</i>	<i>1992</i> <i>10/24/16 RES</i>
<input checked="" type="checkbox"/>	<input type="checkbox"/>	Plans Examiner Certification	<i>1992</i> <i>2008</i>
<input checked="" type="checkbox"/>	<input checked="" type="checkbox"/>	Building Inspector Certification	<i>1992</i> <i>6/2014</i>
<input checked="" type="checkbox"/>	<input checked="" type="checkbox"/>	Mechanical Inspector Certification	<i>1992</i> <i>2017</i>
Building Plans Examiner Certification			
Mechanical Plans Examiner Certification			
Fire Protection Plans Examiner Certification			
Electrical Plans Examiner Certification			
Plumbing Plans Examiner Certification			
Fire Protection Inspector Certification			
Electrical Safety Inspector Certification			
Plumbing Inspector Certification			
Fire Safety Inspector Certification			
Fire Protection System Designer Certification			
Medical Gas Piping Inspector Certification			

LALONDE  
Last Name

DOUGLAS  
First Name

1992  
BBS Certification ID

**SECTION 3: EMPLOYMENT/EDUCATION**

Formal Education	<u>OWENS COMMUNITY COLLEGE</u>	Date Graduated	
	<u>AAS ARCHITECTURAL ENGINEERING TECHNOLOGY</u>		<u>DEC 7 2005</u>
	<u>CERTIFICATES IN AUTO CAD, INSPECTOR, SURVEYING LEVEL 1 &amp; 2</u>		
Related Vocational or Technical Training		Years' Experience	
	<u>3 YRS NONG INC., 2 YRS GOLIS ENGINEERING</u>		<u>3 &amp; 2 YRS</u>
	<u>2.5 YRS TOLEDO ENGINEERING</u>		<u>2.5 YRS</u>
U.S. Military construction experience (MOS or other designation):		Years' Experience	
Place of Employment:		Years' Employed	
	<u>CITY OF TOLEDO DIVISION OF INSPECTION</u>		<u>JUNE 2008 to 3.5 yrs</u>
			<u>PRESENT</u>

**SECTION 4: APPLICANTS REQUESTING MEDICAL GAS INSPECTOR CERTIFICATION**

Attach proof of certification by an ASSE recognized third-party certifier in accordance with ASSE standard 6020.

**SECTION 5: OBC BUILDING INSPECTION EXPERIENCE PERFORMED FOR A BBS CERTIFIED BUILDING DEPARTMENT**

BBS Certified Building Department	BBS Certified Position/Title	Duties	Date of Service, Length of Time (MM/DD/YY)
<u>CITY OF TOLEDO</u>	<u>RESI PLANS EXAMNER</u>	<u>REVIEW NEW &amp; EXISTING HOMES/ STRUCTURES FOR COMPLIANCE SITE, ZONING, FLOOD, STRUCTURE MEPS PREPARE, TRACK, ISSUE &amp; ASSIST W/OCCUPANCY CERT. &amp; PLAN SUBMITTAL RESI &amp; COMMERCIAL STOP WORK ORDER PROCESSING &amp; COMPLIANCE OF CORRECTIONS</u>	<u>2008-2015 FEB</u>
<u>CITY OF TOLEDO</u>	<u>BUILDING INSPECTOR RESI &amp; COMMERCIAL</u>	<u>INSP ALL PHASES OF CONSTRUCTION INCLUDING PERFORMING FLOOD PLAN EVALUATION</u> <ul style="list-style-type: none"> <li>- SCHEDULING INSPECTIONS</li> <li>- ASSIST CBO W/ COMPLAINTS</li> <li>- EVALUATION OF UNSAFE STRUCTURES</li> <li>- ISSUING FIELD CORRECTION NOTICES</li> <li>- ASSIST/HELP GAINING COMPLIANCE</li> <li>- ASSIST WITH FINAL OCCUPANCY PREPERATION</li> <li>- REVIEWING OVERALL PROJECT FOR PROPER PERMITTING</li> <li>- ASSISTING BLDG OFFICIAL W/PRE-CON MTC'S</li> </ul>	<u>FEB 2015 TO PRESENT 2022</u>



LALONDE

Last Name

DOUGLAS

First Name

1992

BBS Certification ID

**SECTION 6: ELECTRICAL SAFETY INSPECTOR (ESI) - SPECIFIC EXPERIENCE QUALIFICATIONS**

Applicants for Electrical Safety Inspector Only Must Complete This Item

Section 3783 of the Ohio Revised Code specifies that an applicant for a Certificate of Competency as an Electrical Safety Inspector must meet one of the following to qualify to take required examination. Please check the qualification that applies:

1.  Have been a journeyman electrician or equivalent for four years, two of which were as an electrician foreman, and have had two years' experience as a building department electrical inspector trainee;
2.  Have been a journeyman electrician or equivalent for four years and have had three years' experience as a building department electrical inspector trainee;
3.  Have had for four years' experience as a building department electrical inspector trainee;
4.  Have been a journeyman electrician or equivalent for six years;
5.  Am a graduate electrical engineer and registered in the State of Ohio. Registration number: \_\_\_\_\_
6.  Applicant authorizes all testing organizations including ICC to provide test results to the BBS.

**SECTION 7: EXPERIENCE (DO NOT SUBSTITUTE WITH OTHER RESUMES).**

Refer to Experience Requirements Listed in O.A.C. 4101:7-3-01 and O.R.C. 3783

Below, list the specific projects you worked on, and the specific work you performed, your typical duties for each project, and dates of this work. You **must** demonstrate that you have the required number of months (years) of actual, practical experience for the certification requested (see matrix).

Provide letters from certified inspectors, employers, or contractors verifying your experience. Submit copies of any certificates, diplomas, or licenses. Remove all personal information.

**SECTION 7 CONT.: EXPERIENCE**

List Each Construction Project AND Specific Type of Work Performed	Name of Employer, Contact, Address, Telephone Number	Project Time: From _ To _ (MM/YY)
<p>Example: HONG INC.</p> <p>- DRAFTING DESIGN COMMERCIAL UNDER CERTIFIED BUILDING OFFICIAL CURTIS HONG.</p> <p>- BEAM &amp; OTHER STRUCTURAL ELEMENT SIZING</p> <p>- MEP DESIGN</p> <p>- CORRECTION LETTER RESPONSE</p> <p>- PLAN SUBMITTAL CHECK &amp; PREPERATION</p> <p>- CODE REVIEW IN RESPONSE TO CORRECTIONS.</p>	<p>HONG INC. 300 PHILIPS AVE # 843 PEREGRINE OH 43612 419-269-0772</p>	<p>July 2013-May 2014 (10 months)</p> <p>2/01/02 TO 2/05/06</p>
Total Experience on This Page (in Months):		

Board of Building Standards

Application for Interim Certification, Building Department Personnel

LALONDE

Last Name

DOUGLAS

First Name

1992

BBS Certification ID

List Each Construction Project AND Specific Type of Work Performed	Name of Employer, Contact, Address, Telephone Number	Project Time: From To (MM/YY)
<p>GOLIS ENGINEERING</p> <ul style="list-style-type: none"> <li>- DRAFTING DESIGN COMMERCIAL</li> <li>- BEAM &amp; OTHER STRUCTURAL ELEMENT SIZING</li> <li>- MEP DESIGN</li> <li>- CORRECTION LETTER RESPONSE</li> <li>- CODE REVIEW</li> <li>- PLAN SUBMITTAL PREP</li> </ul>		<p>2012 to 2015</p>
<p>CITY OF TOLEDO (ENGINEERING SVCS)</p> <ul style="list-style-type: none"> <li>- SURVEYING</li> <li>- ROAD &amp; STREET LAYOUT CONST.</li> <li>- BOUNDARY &amp; R/W LOCATION SURVEYING</li> <li>- TOPOGRAPHY SURVEYING</li> <li>- ENCROACHMENT VERIFICATION</li> <li>- UTILITY STRUCTURE LAYOUT (PUMP STATION, SEWC BLOG ELECTRICAL BLOGS)</li> <li>- MANHOLE INVENTORY PIPE SIZE, DEPTH, LOCATION</li> <li>- SURVEY SITE GRADING</li> <li>- GENERAL CONSTRUCTION STAKE OUT</li> </ul>	<p>BOB BARCOCK            ENG SVCS 419 245 1315            600 JEFFERSON STE 300            TOL OH 43604</p>	<p>12-1-05 to            6-26-08</p>
<p>CITY OF TOLEDO (BUDG INSP)</p> <p>RPE, BI, MECH, RBO</p> <ul style="list-style-type: none"> <li>- REVIEWED RESI PLANS</li> <li>- COMMERCIAL PLAN TRACKING PREPARATION, WORKFLOW, ISSUANCE OCCUPANCY</li> <li>- RESI &amp; COMMERCIAL ALL PHASE INSPECTIONS</li> <li>- ZONING BOARD SECRETARY (2016- TO PRESENT)</li> <li>- SIGN PERMITS, INSPECTIONS</li> <li>- SITE ZONING VERIFICATION &amp; APPROVAL</li> <li>- LICENSING FOR PROFESSIONALS</li> <li>- ASSIST BUILDING OFFICIAL</li> <li>- PERFORM STRUCTURAL SAFETY MSP &amp; PROVIDE INFO TO OFFICIAL</li> <li>- PLAN TRACKING/ CORRECTIONS</li> <li>- FLOOD PLAIN INSP, RW, APPROVAL</li> </ul>		<p>6-27-08            to            PRESENT 2022</p>
<p>Total Experience on This Page (In Months):</p>		

LALONDE  
Last Name

DOUGLAS  
First Name

1992  
BBS Certification ID

**SECTION 8: PERSONAL HISTORY**

1. Have you ever been convicted of any felony, or any crime involving moral turpitude?

Yes  No

If you answered "Yes" please explain below:

2. Have you served in the U.S. armed services? (If No, skip question 3)

Yes  No

3. If YES, were you discharged under honorable conditions?

Yes  No

If you answered "No" please explain below:

**SECTION 9: CERTIFICATION**

*I certify the information contained in this application is true and complete, and I understand that providing false information may be grounds for not granting certification or for immediate termination of certification at any point in the future, if granted. I authorize the investigation of all statements contained herein and release all parties from all liability for any damage that may result from furnishing the same to Ohio Board of Building Standards. Falsification is a violation of section 2921.13 of the Ohio Revised Code and is punishable as a misdemeanor of the first degree.*

Signature of Applicant: *Douglas Lalonde*

Subscribed and duly sworn before me according to law, by the above named applicant this day 7 of SEPT in the year 2022 at BOBT CENTER, County of Lucas and State of OHIO.

Notary Public: *Lori Straub*



LORI STRAUB  
Notary Public, State of Ohio  
My Commission Expires 1-4-26

**Ohio Board of Building Standards  
Virtual Continuing Education**

02/25/2022

This certifies that

**Douglas Lalonde**

Completed the following course(s):

- Chapter 1 Part 1 \* BBS2022-224 (1.5 ceus, all certifications)
- Chapter 1 Part 2 \* BBS2022-225 (1.5 ceus, all certifications)
- Chapter 34 Part 1 \*\* BBS2022-226 (1.5 ceus, all certifications)
- Chapter 34 Part 2 \*\* BBS2022-227 (1.5 ceus, all certifications)
- Building Official Breakout \* BBS2022-234 (3 ceus, all certifications)



TIMOTHY P. GALVIN, CHAIRMAN

*Ohio Board of Building Standards*

Approved for all certifications  
HSW: Yes



**Member Name: Douglas Lalonde**

**Member ID: 8258343**

## **CERTIFICATES**

<b>NAME</b>	<b>CERT #</b>	<b>VALID UNTIL</b>
Management Module	MM	08/17/2023
Legal Module	MG	05/12/2023
Building Codes and Standards Module	BC	11/03/2022

# *Certificate of Completion*



**Douglas Lalonde**

completed the Ohio Ethics Commission's hour long e-  
course **The Ohio Ethics Law 2022: Just the Facts (of Jaw-  
Dropping Investigations)**

**February 26, 2022**

*Susan Willeke  
Education & Communications  
Administrator*

PRINT

# **Ohio Building Code Academy 2.0**

**November 4, 2019**

**Certification of Completion**

**This is to certify that**

**DOUGLAS LALONDE**

**SUCCESSFULLY COMPLETED THE REQUIREMENTS OF THE OHIO BUILDING CODE ACADEMY  
FOR THE BUILDING OFFICIAL TRACK FOR 6 CONTINUING EDUCATION CONTACT HOURS**

*Gerald O. Holland*

**GERALD O. HOLLAND  
CHAIRMAN**

*Ohio Board of Building Standards*

**BBS2019-630  
APPROVED FOR ALL CERTIFICATIONS  
HSW: Y**



# INTERNATIONAL CODE COUNCIL DOUGLAS LALONDE

*The International Code Council attests that the individual named on this certificate has satisfactorily demonstrated knowledge as required by the International Code Council by successfully completing the prescribed written examination based on codes and standards then in effect, and is hereby issued this certification as:*

**Certified Building Official**

*Given this day February 18, 2022*

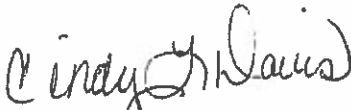
  
**Cindy Davis, CBO**  
**President, Board of Directors**

  
**Dominic Sims, CBO**  
**Chief Executive Officer**

Certificate No. 8258343





# OWENS STATE COMMUNITY COLLEGE

## Engineering Technologies

### Certificate

This is to certify that

**Douglas Edward LaLonde**

has completed all course requirements for a  
**Construction Inspector Certificate**

as offered through

Owens State Community College, Toledo, Ohio

Granted this month of December, 2005.

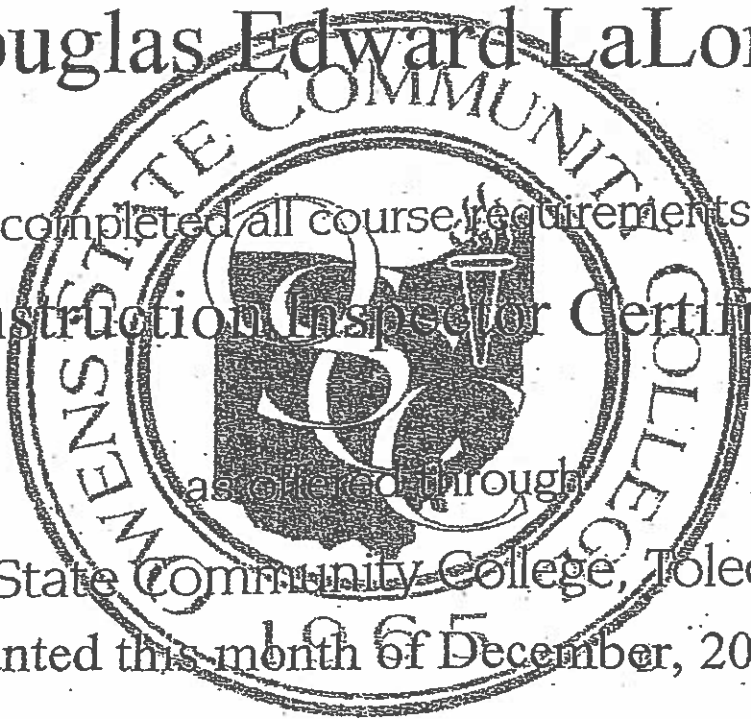

Randy Wharton  
Chairman

Mah Durre  
Dean

Christa Adams  
President

OWENS STATE COMMUNITY COLLEGE

# Engineering Technologies Certificate

This is to certify that

Douglas Edward LaLonde

has completed all course requirements for a  
Architectural CAD Operator Certificate

as offered through

Owens State Community College, Toledo, Ohio

Granted this month of December, 2005.

*Randy Wharton*

Chairman

*Mark Durre*

Dean

*Christa Adams*

President

# Owens State Community College

*By authority of The Board of Trustees and on recommendation of the Faculty,  
in recognition of the completion of the prescribed course of study  
as approved by the Ohio Board of Regents, has conferred upon*

*Douglas Edward LaLonde*

*Associate of Applied Science  
Architectural Engineering Technology*

*with all honors, rights, and privileges belonging thereto.*

*In witness whereof this degree has been signed by the  
duly authorized officers of the College of Toledo, state of Ohio.*

*August 2005*

*Christa Adams*

*President of the College*



*Jack T. Sulgast*

*Chairman of the Board of Trustees*

**File Attachments for Item:**

C-7 Miller, Ronald - RBO

Cert ID: 8934

Current Certifications: None

# Board of Building Standards

Application for Interim Certification, Building Department Personnel

Miller

Last Name

Ronald

First Name

BBS Certification ID

## SECTION 1: CHECK INTERIM CERTIFICATION(S) BEING REQUESTED

<input checked="" type="checkbox"/> Res. Building Official	<input type="checkbox"/> Res. Plans Examiner	<input type="checkbox"/> Res. Building Inspector
	<input type="checkbox"/> Res. Industrial Unit Inspector	<input type="checkbox"/> Res. Mechanical Inspector

## SECTION 2: LIST ANY OHIO LICENSE, CERTIFICATE, OR REGISTRATION HELD

(Mark "T" if Trainee)

Description		Certificate Number	Date Received
Architectural Registration			
P.E. Registration			
Res	Non-Res		
<input type="checkbox"/>	<input type="checkbox"/>	Building Official Certification	
<input type="checkbox"/>	<input type="checkbox"/>	Plans Examiner Certification	
<input type="checkbox"/>	<input type="checkbox"/>	Building Inspector Certification	
<input type="checkbox"/>	<input type="checkbox"/>	Mechanical Inspector Certification	
Building Plans Examiner Certification			
Mechanical Plans Examiner Certification			
Fire Protection Plans Examiner Certification			
Electrical Plans Examiner Certification			
Plumbing Plans Examiner Certification			
Fire Protection Inspector Certification			
Electrical Safety Inspector Certification			
Plumbing Inspector Certification			
Fire Safety Inspector Certification			
Fire Protection System Designer Certification			
Medical Gas Piping Inspector Certification			

## Section 3: Employment/Education

a. Formal Education	Date Graduated
<u>Cleveland Marshall College of Law</u>	<u>May 1987</u>
<u>Indiana University</u>	<u>May 1984</u>
b. Related Vocational or Technical Training	Years' Experience
c. U.S. Military construction experience (MOS or other designation):	Years' Experience
d. Place of Employment:	Years' Employed
<u>S&amp;S Building Realty, Beachwood, Ohio</u>	<u>1993 to Present</u>

# Board of Building Standards

Application for Interim Certification, Building Department Personnel

Miller

Last Name

Ronald

First Name

BBS Certification ID

## SECTION 4: OBC/RCO BUILDING INSPECTION EXPERIENCE PERFORMED FOR A BBS CERTIFIED BUILDING DEPARTMENT

BBS Certified Building Department	BBS Certified Position/Title	Duties	Date of Service, Length of Time (MM/DD/YY)

## SECTION 5: EXPERIENCE (DO NOT SUBSTITUTE WITH OTHER RESUMES).

Refer to Experience Requirements Listed in O.A.C. 4101:7-3-01 and O.R.C. 3783

Below, list the specific projects you worked on, and the specific work you performed, your typical duties for each project, and dates of this work. You **must** demonstrate that you have the required number of months (years) of actual, practical experience for the certification requested (see matrix).

Provide letters from certified inspectors, employers, or contractors verifying your experience. Submit copies of any certificates, diplomas, or licenses. Remove all personal information.

List Each Construction Project AND Specific Type of Work Performed	Name of Employer, Contact, Address, Telephone Number	Project Time: From_ To_ (MM/YY)
<p><i>Example:</i> Children's Hospital, Toledo Structural steel work on addition</p>	<p>Homer Steel and Trade 125 Anytown Street My City, OH, 45454 (419)555-1212</p>	<p>July 2013-May 2014 (10 months)</p>
<p>Residential Contractor of 25 single-family homes in Emerald Lake II development in South Russell Ohio. Acted as supervisor for new home construction and responsible for all aspects, including but not limited to, scheduling and supervising all sub-contractors, ordering building materials, meeting</p>	<p>S &amp; S Building Realty, an Ohio Corporation located at 3149 Willow Lane, Beachwood, Ohio 44122. My brother and I are sole owners. 216-595-0222</p>	<p>April 1993 through December 1996</p>
<p>Total Experience on This Page (In Months):</p>		<p>45</p>

**Board of Building Standards**

Application for Interim Certification, Building Department Personnel

Miller  
Last Name

Ronald  
First Name

\_\_\_\_\_  
BBS Certification ID

**SECTION 5 CONT.: EXPERIENCE**

List Each Construction Project <u>AND</u> Specific Type of Work Performed	Name of Employer, Contact, Address, Telephone Number	Project Time: From _ To _ (MM/YY)
<p>With homeowner and addressing all concerns, and arranging city inspections and obtaining approvals.</p>		
<p>Residential contractor of 250 single-family homes in Aberdeen development in Highland Heights, Ohio. Performed same duties as did in the Emerald Lake II development listed above.</p>	<p>S &amp; S Building Realty</p>	<p>April 1996 - September 2015</p>
<p>Residential contractor of 60 single-family homes in the Sterling Lakes development in Pepper Pike, Ohio. Performed same duties as did in the Emerald Lake II development listed above.</p>	<p>S &amp; S Building Realty</p>	<p>April 2008 - Present</p>
<p><b>Total Experience on This Page (In Months):</b></p>		<p><b>234</b></p>

**Board of Building Standards**

Application for Interim Certification, Building Department Personnel

Miller  
Last Name

Ronald  
First Name

\_\_\_\_\_  
BBS Certification ID

**SECTION 6: PERSONAL HISTORY**

- 1. Have you ever been convicted of any felony, or any crime involving moral turpitude?  Yes  No
- 2. If you answered "Yes" please explain below:
- 3. Have you served in the U.S. armed services? (If No, skip question 3)  Yes  No
- 4. If YES, were you discharged under honorable conditions?  Yes  No  
If you answered "No" please explain below:

**SECTION 7: CERTIFICATION**

I certify the information contained in this application is true and complete, and I understand that providing false information may be grounds for not granting certification or for immediate termination of certification at any point in the future, if granted. I authorize the investigation of all statements contained herein and release all parties from all liability for any damage that may result from furnishing the same to Ohio Board of Building Standards. Falsification is a violation of section 2921.13 of the Ohio Revised Code and is punishable as a misdemeanor of the first degree.

Signature of Applicant: *Ronald Miller*

Subscribed and duly sworn before me according to law, by the above named applicant this day 1 of September in the year 2022 at Pepper Pike, County of Cuyahoga and State of Ohio.

Notary Public: *Brenda J. Stenger*



Brenda J. Stenger  
Notary Public, State of Ohio  
My Commission Expires  
November 23, 2024



August 12, 2022

Mr. Timothy Galvin, Chairman  
Certification Committee  
Ohio Board of Building Standards

RE: Ron Miller, Application for Building Official

Dear Mr. Galvin,

I have been the Building Official for the City of Pepper Pike for the past 6 years. During my tenure in this jurisdiction, I have gotten to know Ron Miller since his company, Sterling Lakes Building Company has constructed numerous homes and additions in the community. Over the years Ron and I have spoken about the career as a code official and I have suggested to him to pursue the avenue of code enforcement. Due to his years in the construction trades and running a building company, his knowledge of the building process, working with residents and dealing with inspectors in many of the other communities gives him a good background for this position. As we struggle to fill the pool of inspectors throughout the nation, I would urge you to accept his application and allow him to begin the process of becoming a code official. Ron would be a good asset to a community.

Sincerely,

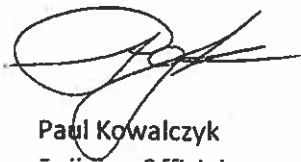

Paul Kowalczyk  
Building Official  
City of Pepper Pike

**INSPECTION SOLUTIONS, LLC**

8460 Lincoln Dr.

Chesterland, Ohio 44026

440-821-2141

August 22, 2022

Mr. Timothy Galvin,  
Chairman Certification Committee  
Board of Building Standards.  
RE: Ron Miller

Dear Mr. Galvin,

I have known Ron Miller for approx. 30 years and have inspected his work during this time. I have never had a problem with his work or inspections. He is very knowledgeable about the code and is always trying to learn. I highly recommend Ron to go through the process of becoming a Building Official.

Any concerns please call.

Thank You,

Dave Hocevar

**File Attachments for Item:**

C-8 Newman, Michael - PI

Cert ID:

Current Certifications: None

# Board of Building Standards

Application for Interim Certification, Building Department Personnel

Newman

Michael

Last Name

First Name

BBS Certification ID

## SECTION 1: CHECK INTERIM CERTIFICATION(S) BEING REQUESTED

<input type="checkbox"/> Building Official	<input type="checkbox"/> Master Plans Examiner	<input type="checkbox"/> Building Inspector	<input type="checkbox"/> Electrical Safety Inspector	<input type="checkbox"/> Fire Protection Inspector
<input type="checkbox"/> Building Plans Examiner	<input type="checkbox"/> Plumbing Plans Examiner	<input type="checkbox"/> Mechanical Plans Examiner	<input type="checkbox"/> Electrical Plans Examiner	<input type="checkbox"/> Fire Protection Plans Examiner
	<input checked="" type="checkbox"/> Plumbing Inspector	<input type="checkbox"/> Mechanical Inspector	<input type="checkbox"/> Non-Residential Industrial Unit Inspector	

## SECTION 2: LIST ANY OHIO LICENSE, CERTIFICATE, OR REGISTRATION HELD

(Mark "T" If Trainee)

Description		Certificate Number	Date Received
Architectural Registration			
P.E. Registration			
Res	Non-Res		
<input type="checkbox"/>	<input type="checkbox"/>	Building Official Certification	
<input type="checkbox"/>	<input type="checkbox"/>	Plans Examiner Certification	
<input type="checkbox"/>	<input type="checkbox"/>	Building Inspector Certification	
<input type="checkbox"/>	<input type="checkbox"/>	Mechanical Inspector Certification	
Building Plans Examiner Certification			
Mechanical Plans Examiner Certification			
Fire Protection Plans Examiner Certification			
Electrical Plans Examiner Certification			
Plumbing Plans Examiner Certification			
Fire Protection Inspector Certification			
Electrical Safety Inspector Certification			
Plumbing Inspector Certification			
Fire Safety Inspector Certification			
Fire Protection System Designer Certification			
Medical Gas Piping Inspector Certification			

Newman

Michael

*Last Name*

*First Name*

*BBS Certification ID*

**SECTION 3: EMPLOYMENT/EDUCATION**

Formal Education	Date Graduated
Westerville North High School	2013
Related Vocational or Technical Training	Years' Experience
Association of Plumbing and Hydronics Contractors	4
U.S. Military construction experience (MOS or other designation):	Years' Experience
Place of Employment:	Years' Employed
Accurate Plumbing Inc	2013-2020
Muetzel Plumbing	2020-Present

**SECTION 4: APPLICANTS REQUESTING MEDICAL GAS INSPECTOR CERTIFICATION**

*Attach proof of certification by an ASSE recognized third-party certifier in accordance with ASSE standard 6020.*

**SECTION 5: OBC BUILDING INSPECTION EXPERIENCE PERFORMED FOR A BBS CERTIFIED BUILDING DEPARTMENT**

BBS Certified Building Department	BBS Certified Position/Title	Duties	Date of Service, Length of Time (MM/DD/YY)

Newman

Michael

*Last Name*

*First Name*

*BBS Certification ID*

**SECTION 6: ELECTRICAL SAFETY INSPECTOR (ESI) - SPECIFIC EXPERIENCE QUALIFICATIONS**

Applicants for Electrical Safety Inspector Only Must Complete This Item

Section 3783 of the Ohio Revised Code specifies that an applicant for a Certificate of Competency as an Electrical Safety Inspector must meet one of the following to qualify to take required examination. Please check the qualification that applies:

1.  Have been a journeyman electrician or equivalent for four years, two of which were as an electrician foreman, and have had two years' experience as a building department electrical inspector trainee;
2.  Have been a journeyman electrician or equivalent for four years and have had three years' experience as a building department electrical inspector trainee;
3.  Have had for four years' experience as a building department electrical inspector trainee;
4.  Have been a journeyman electrician or equivalent for six years;
5.  Am a graduate electrical engineer and registered in the State of Ohio. Registration number: \_\_\_\_\_
6.  Applicant authorizes all testing organizations including ICC to provide test results to the BBS.

**SECTION 7: EXPERIENCE (DO NOT SUBSTITUTE WITH OTHER RESUMES).**

Refer to Experience Requirements Listed in O.A.C. 4101:7-3-01 and O.R.C. 3783

Below, list the specific projects you worked on, and the specific work you performed, your typical duties for each project, and dates of this work. You must demonstrate that you have the required number of months (years) of actual, practical experience for the certification requested (see matrix).

Provide letters from certified inspectors, employers, or contractors verifying your experience. Submit copies of any certificates, diplomas, or licenses. Remove all personal information.

**SECTION 7 CONT.: EXPERIENCE**

List Each Construction Project <b>AND</b> Specific Type of Work Performed	Name of Employer, Contact, Address, Telephone Number	Project Time: From_ To_ (MM/YY)
<i>Example:</i> Children's Hospital, Toledo Structural steel work on addition 2375 LANE WOODS DR COLUMBUS OH Residential plumbing	Homer Steel and Trade 125 Anytown Street My City, OH, 45454 (419)555-1212	July 2013-May 2014 (10 months)
1421 DOTEN AVE COLUMBUS OH Residential remodel residential plumbing	Accurate Plumbing 7595 Fishel Dr. S. 614-526-0131	Oct. 2014- May 2015 7 months
780 SPIVEY LN GALLOWAY OH Fire Restoration residential plumbing	Accurate Plumbing 7595 Fishel Dr. S. 614-526-0131	May 2015- Nov. 2015 6 months
1129 LENORE AVE COLUMBUS OH Residential new construction residential plumbing	Accurate Plumbing 7595 Fishel Dr. S. 614-526-0131	Nov. 2015- July 2016 8 months
		July 2016- Oct. 2016 3 months
<b>Total Experience on This Page (In Months):</b>		<b>24</b>

**Board of Building Standards**

Application for Interim Certification, Building Department Personnel

Newman

Michael

*Last Name*

*First Name*

*BBS Certification ID*

List Each Construction Project <b>AND</b> Specific Type of Work Performed	Name of Employer, Contact, Address, Telephone Number	Project Time: From_ To _ (MM/YY)
3891 STONEWATER DR COLUMBUS OH Residential new construction residential plumbing	Accurate Plumbing 7595 Fishel Dr. S. 614-526-0131	Sept. 2016- April 2017 7 months
278 GLENMONT AVE COLUMBUS OH Residential remodel residential plumbing	Accurate Plumbing 7595 Fishel Dr. S. 614-526-0131	April 2017- Dec. 2017 8 months
4787 LARWELL DR COLUMBUS OH Residential remodel residential plumbing	Accurate Plumbing 7595 Fishel Dr. S. 614-526-0131	Nov. 2017- May 2018 6 months
174 NURSERY LN COLUMBUS OH Residential remodel residential plumbing	Accurate Plumbing 7595 Fishel Dr. S. 614-526-0131	May 2018- Dec. 2018 7 months
1959 SCIOTO POINTE DR COLUMBUS OH Residential remodel residential plumbing	Accurate Plumbing 7595 Fishel Dr. S. 614-526-0131	Jan. 2019- Aug. 2019 8 months
717 S 3RD ST COLUMBUS OH Residential remodel residential plumbing	Accurate Plumbing 7595 Fishel Dr. S. 614-526-0131	Aug. 2019- April 2020 8 months
1 MIRANOVA PL 1630 COLUMBUS OH Commercial remodel commercial plumbing	Accurate Plumbing 7595 Fishel Dr. S. 614-526-0131	April 2020- Aug. 2020 4 months
Friendship Village Commercial remodel commercial plumbing	Muetzel Plumbing 1661 Kenny Rd 614-299-7700	Aug. 2020- March 2021 7 months
Danbury Assisted Living Commercial new build commercial plumbing	Muetzel Plumbing 1661 Kenny Rd 614-299-7700	March 2021- Oct. 2021 6 months
Andelyn Bioscience tenant buildout commercial plumbing	Muetzel Plumbing 1661 Kenny Rd 614-299-7700	Oct. 2021- June 2022 7 months
Whiplash Logistics tenant buildout commercial plumbing	Muetzel Plumbing 1661 Kenny Rd 614-299-7700	Feb.2022- April 2022 2 months
Muirfield Turf Facility Commercial new build commercial plumbing	Muetzel Plumbing 1661 Kenny Rd 614-299-7700	April 2022- Aug. 2022 4 months
<b>Total Experience on This Page (in Months):</b>		<b>74</b>

Newman

Michael

Last Name

First Name

BBS Certification ID

SECTION 8: PERSONAL HISTORY

1. Have you ever been convicted of any felony, or any crime involving moral turpitude?

Yes  No

If you answered "Yes" please explain below:

2. Have you served in the U.S. armed services? (If No, skip question 3)

Yes  No

3. If YES, were you discharged under honorable conditions?

Yes  No

If you answered "No" please explain below:

Empty table for explanation of "No" answers.

SECTION 9: CERTIFICATION

I certify the information contained in this application is true and complete, and I understand that providing false information may be grounds for not granting certification or for immediate termination of certification at any point in the future, if granted. I authorize the investigation of all statements contained herein and release all parties from all liability for any damage that may result from furnishing the same to Ohio Board of Building Standards. Falsification is a violation of section 2921.13 of the Ohio Revised Code and is punishable as a misdemeanor of the first degree.

Signature of Applicant: [Handwritten Signature]

Subscribed and duly sworn before me according to law, by the above named applicant this day 2nd of Sept in the year 2022 at 275 Crosslake Ct, County of Franklin and State of Ohio.

Notary Public: Cynthia L McComas



CYNTHIA L. McCOMAS, Notary Public In and for the State of Ohio My Commission Expires 05/28/23



**File Attachments for Item:**

C-9 Spencer, Martin FPI

Certification ID# 8940

Current certifications- none, FSI since 1999.

Last Name First Name BBS Certification ID

**SECTION 1: CHECK INTERIM CERTIFICATION(S) BEING REQUESTED**

Building Official	Master Plans Examiner	Building Inspector	Electrical Safety Inspector	Fire Protection Inspector
Building Plans Examiner	Plumbing Plans Examiner	Mechanical Plans Examiner	Electrical Plans Examiner	Fire Protection Plans Examiner
	Plumbing Inspector	Mechanical Inspector	Non-Residential Industrial Unit Inspector	

**SECTION 2: LIST ANY OHIO LICENSE, CERTIFICATE, OR REGISTRATION HELD**

(Mark "T" If Trainee)

Description		Certificate Number	Date Received
Architectural Registration			
P.E. Registration			
Res	Non-Res		
		Building Official Certification	
		Plans Examiner Certification	
		Building Inspector Certification	
		Mechanical Inspector Certification	
Building Plans Examiner Certification			
Mechanical Plans Examiner Certification			
Fire Protection Plans Examiner Certification			
Electrical Plans Examiner Certification			
Plumbing Plans Examiner Certification			
Fire Protection Inspector Certification			
Electrical Safety Inspector Certification			
Plumbing Inspector Certification			
Fire Safety Inspector Certification		91271	04/22/1999
Fire Protection System Designer Certification			
Medical Gas Piping Inspector Certification			

**Board of Building Standards** Application for Interim Certification, Building Department Personnel

*Last Name First Name BBS Certification ID*

**SECTION 3: EMPLOYMENT/EDUCATION**

Formal Education	Date Graduated
Ohio Fire Academy - Fire Safety Inspector	04/1999
Sinclair Community College - AAS Fire Science Technology/ Fire Administration	05/2020
Related Vocational or Technical Training	Years' Experience
U.S. Military construction experience (MOS or other designation):	Years' Experience
Place of Employment:	Years' Employed
Norwich Township Fire Department	19 Years

**SECTION 4: APPLICANTS REQUESTING MEDICAL GAS INSPECTOR CERTIFICATION**

*Attach proof of certification by an ASSE recognized third-party certifier in accordance with ASSE standard 6020.*

**SECTION 5: OBC BUILDING INSPECTION EXPERIENCE PERFORMED FOR A BBS CERTIFIED BUILDING DEPARTMENT**

BBS Certified Building Department	BBS Certified Position/Title	Duties	Date of Service, Length of Time (MM/DD/YY)

--	--	--	--

Ohio Board of Building Standards 4/1/2019 Form # 102

**Board of Building Standards** Application for Interim Certification, Building Department Personnel

*Last Name First Name BBS Certification ID*

**SECTION 6: ELECTRICAL SAFETY INSPECTOR (ESI) - SPECIFIC EXPERIENCE**

**QUALIFICATIONS** Applicants for Electrical Safety Inspector Only Must Complete This Item

Section 3783 of the Ohio Revised Code specifies that an applicant for a Certificate of Competency as an Electrical Safety Inspector must meet one of the following to qualify to take required examination. Please check the qualification that applies:

1. Have been a journeyman electrician or equivalent for four years, two of which were as an electrician foreman, and have had two years' experience as a building department electrical inspector trainee;
2. Have been a journeyman electrician or equivalent for four years and have had three years' experience as a building department electrical inspector trainee;
3. Have had for four years' experience as a building department electrical inspector trainee; 4. Have been a journeyman electrician or equivalent for six years;
5. Am a graduate electrical engineer and registered in the State of Ohio. Registration number: \_\_\_\_\_
6. Applicant authorizes all testing organizations including ICC to provide test results to the BBS.

**SECTION 7: EXPERIENCE (DO NOT SUBSTITUTE WITH OTHER RESUMES).**

Refer to Experience Requirements Listed in O.A.C. 4101:7-3-01 and O.R.C. 3783 Below, list the specific projects you worked on, and the specific work you performed, your typical duties for each project, and dates of this work. You **must** demonstrate that you have the required number of months (years) of actual, practical experience for the certification requested (see matrix).

Provide letters from certified inspectors, employers, or contractors verifying your experience. Submit copies of any certificates, diplomas, or licenses. Remove all personal information.

**SECTION 7 CONT.: EXPERIENCE**

List Each Construction Project <u>AND</u> Specific Type of Work Performed	Name of Employer, Contact, Address, Telephone Number	Project Time: From _ To _ (MM/YY)
---	---	--------------------------------------

<i>Fire Safety Inspections for Norwich Township, Brown township and the City of Hilliard</i>	<i>Norwich Township Fire Department 5181 Northwest Parkway Hilliard Ohio, 43026 Fire Marshal, Scott Tigner 614-876-7694</i>	<i>February 2003 to Present</i>
<b>Total Experience on This Page (In Months):</b>		<b>19 years</b>

Ohio Board of Building Standards 4/1/2019 Form # 102

**Board of Building Standards** Application for Interim Certification, Building Department Personnel

*Last Name First Name BBS Certification ID*

<b>List Each Construction Project AND Specific Type of Work Performed</b>	<b>Name of Employer, Contact, Address, Telephone Number</b>	<b>Project Time: From_ To _ (MM/YY)</b>
---	---	---

<b>Total Experience on This Page (In Months):</b>		

Ohio Board of Building Standards 4/1/2019 Form # 102

**Board of Building Standards** Application for Interim Certification, Building Department Personnel *Last*

Name First Name BBS Certification ID

**SECTION 8: PERSONAL HISTORY**

1. Have you ever been convicted of any felony, or any crime involving moral turpitude? Yes  No

If you answered "Yes" please explain below:

2. Have you served in the U.S. armed services? (If No, skip question 3) Yes  No  3. If YES,

were you discharged under honorable conditions? Yes No If you answered "No" please explain below:

**SECTION 9: CERTIFICATION**

*I certify the information contained in this application is true and complete, and I understand that providing false information may be grounds for not granting certification or for immediate termination of certification at any point in the future, if granted. I authorize the investigation of all statements contained herein and release all parties from all liability for any damage that may result from furnishing the same to Ohio Board of Building Standards. Falsification is a violation of section 2921.13 of the Ohio Revised Code and is punishable as a misdemeanor of the first degree.*

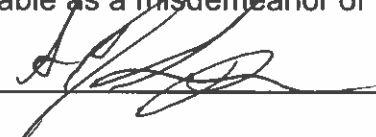
Signature of Applicant: 

Subscribed and duly sworn before me according to law, by the above named applicant this day 8<sup>th</sup> of September in the year 2022 at Franklin/Hilliard County of Franklin and State of Ohio.

Notary Public: 

SEAL



# Certification Verification

**Name(Last, First):** Spencer, Martin

**CertNo:** 91271

**City:** Dublin

**State:** Ohio

**County:** Franklin

Certification Level	Status	Effective Date	Expiration Date	Additional Information
EMS Instructor	Active	4/15/2022	4/15/2025	
Paramedic	Active	4/15/2022	4/15/2025	
Fire Instructor	Active	4/15/2022	4/15/2025	
Fire Safety Inspector	Active	4/15/2022	4/15/2025	
Firefighter II	Active	4/15/2022	4/15/2025	
EMS Instructor	Inactive	4/15/2019	4/15/2022	
Paramedic	Inactive	4/15/2019	4/15/2022	
Fire Instructor	Inactive	4/15/2019	4/15/2022	
Fire Safety Inspector	Inactive	4/15/2019	4/15/2022	
Firefighter II	Inactive	4/15/2019	4/15/2022	
EMS Instructor	Inactive	4/15/2016	4/15/2019	
Paramedic	Inactive	4/15/2016	4/15/2019	
Fire Instructor	Inactive	4/15/2016	4/15/2019	
Fire Safety Inspector	Inactive	4/15/2016	4/15/2019	
Firefighter II	Inactive	4/15/2016	4/15/2019	
EMS Instructor	Inactive	5/26/2015	4/15/2016	
Paramedic	Inactive	4/15/2013	4/15/2016	
Fire Instructor	Inactive	11/15/2013	4/15/2016	
Fire Safety Inspector	Inactive	4/15/2013	4/15/2016	
Firefighter II	Inactive	4/15/2013	4/15/2016	
Paramedic	Inactive	4/24/2010	4/15/2013	
Fire Safety Inspector	Inactive	4/15/2010	4/15/2013	
Firefighter II	Inactive	4/15/2010	4/15/2013	
Paramedic	Inactive	4/24/2007	4/24/2010	
Fire Safety Inspector	Inactive	2/22/2008	4/15/2010	
Firefighter II	Inactive	2/22/2008	4/15/2010	



Certification Level	Status	Effective Date	Expiration Date	Additional Information
Fire Safety Inspector	Inactive	4/22/1999	2/22/2008	
Firefighter II	Inactive	11/14/1997	2/22/2008	
Paramedic	Inactive	4/24/2004	4/24/2007	
Paramedic	Inactive	4/24/2001	4/24/2004	
Advanced Emergency Medical Technician	Inactive	5/26/2000	5/26/2003	
Emergency Medical Technician	Inactive	8/7/1998	8/7/2001	

**EMS certification titles are being updated to align with national EMS provider titles. All titles, as denoted below, are valid and mean the same thing under Ohio law. New cards will not be issued to those certified prior to the change until the certificate is renewed or a new certification obtained.**

**First Responder -> Emergency Medical Responder (EMR)**

**EMT-Basic -> Emergency Medical Technician (EMT)**

**EMT-Intermediate -> Advanced EMT (AEMT)**

**EMT-Paramedic -> Paramedic**

## Certification Status Definitions

<b>Active</b>	The certificate is current and valid.
<b>Denial</b>	The application was denied due to a violation of either Ohio Revised Code Chapter 4765 or the provisions of Ohio Administrative Code 4765.
<b>Discipline</b>	Sanctions have been issued against the certificate due to a violation of either Ohio Revised Code Chapter 4765 or the provisions of Ohio Administrative Code 4765.
<b>Extension - Functioning</b>	The certificate holder was approved for an extension of time to complete the renewal requirements and may function during that extension period.
<b>Extension - Non Functioning</b>	The certificate holder was approved for an extension of time to complete the renewal requirements and may <u>not</u> function during that extension period.
<b>Inactive</b>	The certificate is no longer current and valid.
<b>Incomplete Application</b>	The application was not processed and the certification was not issued due to information not being provided by the applicant.
<b>Needs Approval</b>	The application requires further review before it can be considered for processing.
<b>Pending</b>	For <u>renewal</u> applications, the certificate is pending the effective date when it will become "Active." A new certification card will be mailed to the certificate holder <b>after</b> that date. For <u>initial</u> applications, the certificate will remain in "Pending" status until midnight of the effective date when it will change to "Active." A new card will be mailed to the certificate holder <b>after</b> that date.
<b>Pending School Approval</b>	The application is pending the approval of the EMS-accredited training institution. The applicant has not met all requirements for certification.

<b>Permanent Denial</b>	The application was permanently denied due to a violation of either Ohio Revised Code Chapter 4765 or the provisions of Ohio Administrative Code 4765, and the certificate holder is not eligible to re-apply for this certificate.
<b>Permanent Revocation</b>	The application was permanently revoked due to a violation of either Ohio Revised Code Chapter 4765 or the provisions of Ohio Administrative Code 4765, and the certificate holder is not eligible to re-apply for this certificate.
<b>Rejected</b>	Prior to December, 2016, this status was assigned when a certificate holder either surrendered a certificate or withdrew an application. After December, 2016, "Rejected" is assigned when an application has been submitted in error.
<b>Revoked</b>	The certificate was revoked due to a violation of either Ohio Revised Code Chapter 4765 or the provisions of Ohio Administrative Code 4765.
<b>Surrendered</b>	The certificate holder voluntarily surrendered the certificate; may be eligible to reinstate or re-apply.
<b>Suspension</b>	The certificate holder is prohibited from practicing during a specified time due to a violation of Ohio Revised Code Chapter 4765 or the provisions of Ohio Administrative Code 4765.

© 2022 - Ohio Department of Public Safety

**File Attachments for Item:**

C-10 Stewart, Philip - BO, BPE, PPE, MechPE, EPE, FPPE

Certification ID# 1429

Current certifications- BI, MI, FPI, ESI, RBO

**Board of Building Standards**

Application for Interim Certification, Building Department Personnel

Stewart  
Last Name

Phil  
First Name

1429  
BBS Certification ID

**SECTION 1: CHECK INTERIM CERTIFICATION(S) BEING REQUESTED**

<input checked="" type="checkbox"/> Building Official	<input type="checkbox"/> Master Plans Examiner	<input type="checkbox"/> Building Inspector	<input type="checkbox"/> Electrical Safety Inspector	<input type="checkbox"/> Fire Protection Inspector
<input checked="" type="checkbox"/> Building Plans Examiner	<input checked="" type="checkbox"/> Plumbing Plans Examiner	<input checked="" type="checkbox"/> Mechanical Plans Examiner	<input checked="" type="checkbox"/> Electrical Plans Examiner	<input checked="" type="checkbox"/> Fire Protection Plans Examiner
	<input checked="" type="checkbox"/> Plumbing Inspector	<input type="checkbox"/> Mechanical Inspector	<input type="checkbox"/> Non-Residential Industrial Unit Inspector	

**SECTION 2: LIST ANY OHIO LICENSE, CERTIFICATE, OR REGISTRATION HELD**

(Mark "T" If Trainee)

Description		Certificate Number	Date Received
Architectural Registration			
P.E. Registration			
Res	Non-Res		
<input checked="" type="checkbox"/>	<input type="checkbox"/>	Building Official Certification	1429 2006
<input type="checkbox"/>	<input type="checkbox"/>	Plans Examiner Certification	
<input checked="" type="checkbox"/>	<input checked="" type="checkbox"/>	Building Inspector Certification	1429 2006
<input checked="" type="checkbox"/>	<input checked="" type="checkbox"/>	Mechanical Inspector Certification	1429 2006
Building Plans Examiner Certification			
Mechanical Plans Examiner Certification			
Fire Protection Plans Examiner Certification			
Electrical Plans Examiner Certification			
Plumbing Plans Examiner Certification			
Fire Protection Inspector Certification		1429	2006
Electrical Safety Inspector Certification		1429	removed 1983
Plumbing Inspector Certification			
Fire Safety Inspector Certification		1429	removed
Fire Protection System Designer Certification			
Medical Gas Piping Inspector Certification			

**Board of Building Standards**

Application for Interim Certification, Building Department Personnel

Stewart  
Last Name

Phil  
First Name

1429  
BBS Certification ID

**SECTION 3: EMPLOYMENT/EDUCATION**

Formal Education	Max Hayes high school	Date Graduated	
	Cleveland State Technical		1974
Related Vocational or Technical Training	Electric, HVAC, Plumbing Boilers, steam and hot water	Years' Experience	ALL 45 years
U.S. Military construction experience (MOS or other designation):	None	Years' Experience	None
Place of Employment:	CIANT school, Bass Heating, Nottingham hem design	Years' Employed	45 years

**SECTION 4: APPLICANTS REQUESTING MEDICAL GAS INSPECTOR CERTIFICATION**

Attach proof of certification by an ASSE recognized third-party certifier in accordance with ASSE standard 6020.

**SECTION 5: OBC BUILDING INSPECTION EXPERIENCE PERFORMED FOR A BBS CERTIFIED BUILDING DEPARTMENT**

BBS Certified Building Department	BBS Certified Position/Title	Duties	Date of Service, Length of Time (MM/DD/YY)
City of East Cleveland	Electric Safety Inspector	Inspect Building for code updates New and old	3 years
Lake County Building Dept.	Building Inspector Fire Inspector	Inspect County Buildings and code violations New Builds Res. and Non Res. Residential plans EXAMINER Electric, mechanical Plumbing Inspections	3 years

Stewart  
Last Name

Phil  
First Name

1429  
BBS Certification ID

**SECTION 6: ELECTRICAL SAFETY INSPECTOR (ESI) - SPECIFIC EXPERIENCE QUALIFICATIONS**

Applicants for Electrical Safety Inspector Only Must Complete This Item

Section 3783 of the Ohio Revised Code specifies that an applicant for a Certificate of Competency as an Electrical Safety Inspector must meet one of the following to qualify to take required examination. Please check the qualification that applies:

1.  Have been a journeyman electrician or equivalent for four years, two of which were as an electrician foreman, and have had two years' experience as a building department electrical inspector trainee;
2.  Have been a journeyman electrician or equivalent for four years and have had three years' experience as a building department electrical inspector trainee;
3.  Have had for four years' experience as a building department electrical inspector trainee;
4.  Have been a journeyman electrician or equivalent for six years;
5.  Am a graduate electrical engineer and registered in the State of Ohio. Registration number: \_\_\_\_\_
6.  Applicant authorizes all testing organizations including ICC to provide test results to the BBS.

**SECTION 7: EXPERIENCE (DO NOT SUBSTITUTE WITH OTHER RESUMES).**

Refer to Experience Requirements Listed in O.A.C. 4101:7-3-01 and O.R.C. 3783

Below, list the specific projects you worked on, and the specific work you performed, your typical duties for each project, and dates of this work. You **must** demonstrate that you have the required number of months (years) of actual, practical experience for the certification requested (see matrix).

Provide letters from certified inspectors, employers, or contractors verifying your experience. Submit copies of any certificates, diplomas, or licenses. Remove all personal information.

**SECTION 7 CONT.: EXPERIENCE**

List Each Construction Project AND Specific Type of Work Performed	Name of Employer, Contact, Address, Telephone Number	Project Time: From _ To _ (MM/YY)
<p>Example: Children's Hospital, Toledo Structural steel work on addition</p> <p>Cuyahoga Juvenile Court Cleveland Plumbing, vents and drains concrete slabs Pole Erection</p>	<p>Homer Steel and Trade 125 Anytown Street My City, OH, 45454 (419)555-1212</p> <p>M+S Contractors 952 Nelzview Rd</p>	<p>July 2013-May 2014 (10 months)</p> <p>Feb 1991-1995 08 months</p>
Total Experience on This Page (In Months):		

**Board of Building Standards**

Application for Interim Certification, Building Department Personnel

Stewart  
Last Name

Phil  
First Name

1429  
BBS Certification ID

List Each Construction Project AND Specific Type of Work Performed	Name of Employer, Contact, Address, Telephone Number	Project Time: From_ To _ (MM/YY)
<p>CIA Art School Elec, Plumbing vents drains Concrete Slabs 50. Elec Files Install Roof contracting Kaiser Hospital Oakland, Ca</p>	<p>Cleveland Ins of Art 1700 Euclid Ave <del>216-822-2000</del> 11510 Euclid Ave 216-421-7418</p> <p>Kaiser Permanente 12301 Show Rd. 362-2000</p>	<p>2005 To 2005 120 months</p> <p>1981 - 1987 96 months</p>
<p><b>Total Experience on This Page (In Months):</b></p>		

Stewart  
Last Name

Phil  
First Name

1429  
BBS Certification ID

**SECTION 8: PERSONAL HISTORY**

1. Have you ever been convicted of any felony, or any crime involving moral turpitude?

Yes  No

If you answered "Yes" please explain below:

2. Have you served in the U.S. armed services? (If No, skip question 3)

Yes  No

3. If YES, were you discharged under honorable conditions?

Yes  No

If you answered "No" please explain below:

**SECTION 9: CERTIFICATION**

I certify the information contained in this application is true and complete, and I understand that providing false information may be grounds for not granting certification or for immediate termination of certification at any point in the future, if granted. I authorize the investigation of all statements contained herein and release all parties from all liability for any damage that may result from furnishing the same to Ohio Board of Building Standards. Falsification is a violation of section 2921.13 of the Ohio Revised Code and is punishable as a misdemeanor of the first degree.

Signature of Applicant: 

Subscribed and duly sworn before me according to law, by the above named applicant this day 2<sup>nd</sup> of August in the year 2022 at Richmond Hts, County of Cuyahoga and State of Ohio.

Notary Public: 



ALISA TYLER  
Notary Public  
State of Ohio  
My Comm. Expires  
January 25, 2025





**Department  
of Commerce**

Division of Industrial Compliance  
Ohio Construction Industry  
Licensing Board O.C.I.L.B.

Mike DeWine  
Sheryl Maxfield

STEWART, PHIL

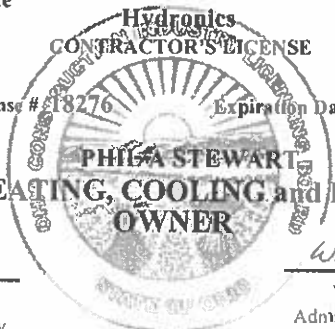

Mike DeWine Governor	Sheryl Maxfield Director
	
<b>Hydronics</b> <b>CONTRACTOR'S LICENSE</b> Ohio License # 18276      Expiration Date: 09/30/2023 <b>PHIL A STEWART</b> <b>BASS HEATING, COOLING and PLUMBING</b> <b>OWNER</b>	
<i>Carol Ross</i>	<i>William Koester</i>
Carol A. Ross Board Secretary	William Koester Administrative Chairperson

This is YOUR license. Plan Approvals obtained with YOUR license and posting of YOUR license indicates that YOU and YOUR liability insurance are assuming all responsibility for any projects performed under this license.

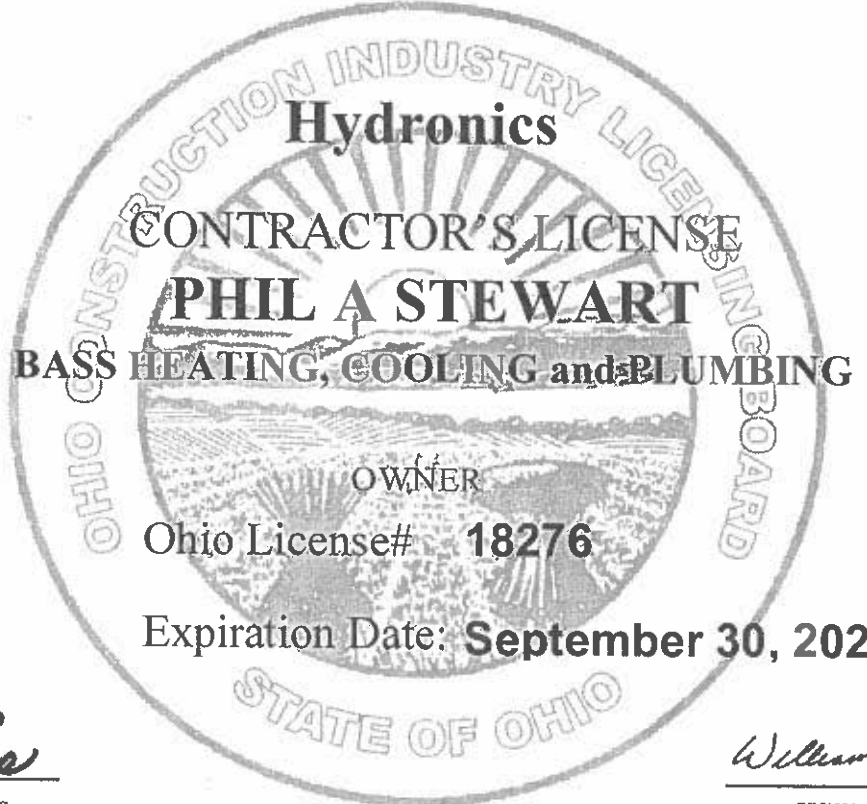
Mike DeWine Governor	Sheryl Maxfield Director
LICENSE MUST BE POSTED ON JOB SITE	LICENSE MUST BE POSTED ON JOB SITE
	
<b>Hydronics</b> <b>CONTRACTOR'S LICENSE</b> <b>PHIL A STEWART</b> <b>BASS HEATING, COOLING and PLUMBING</b> <b>OWNER</b> Ohio License# 18276 Expiration Date: <b>September 30, 2023</b>	
<i>Carol Ross</i>	<i>William Koester</i>
Carol A. Ross Board Secretary	William Koester Administrative Chairperson



**Department of Commerce**

Division of Industrial Compliance  
Ohio Construction Industry  
Licensing Board O.C.I.L.B.

Mike DeWine  
Sheryl Maxfield

STEWART, PHIL



Mike DeWine Governor	Sheryl Maxfield Director
	
<b>Plumbing</b> <b>CONTRACTOR'S LICENSE</b> Ohio License # 18276      Expiration Date: 09/30/2023 <b>PHIL A STEWART</b> <b>BASS HEATING, COOLING and PLUMBING</b> <b>OWNER</b>	
<i>Carol Ross</i>	<i>William Koester</i>
Carol A. Ross Board Secretary	William Koester Administrative Chairperson

This is YOUR license. Plan Approvals obtained with YOUR license and posting of YOUR license indicates that YOU and YOUR liability insurance are assuming all responsibility for any projects performed under this license.

Mike DeWine Governor	Sheryl Maxfield Director
LICENSE MUST BE POSTED ON JOB SITE	LICENSE MUST BE POSTED ON JOB SITE
	
<b>Plumbing</b> <b>CONTRACTOR'S LICENSE</b> <b>PHIL A STEWART</b> <b>BASS HEATING, COOLING and PLUMBING</b> <b>OWNER</b> Ohio License# 18276 Expiration Date: <b>September 30, 2023</b>	
<i>Carol Ross</i>	<i>William Koester</i>
Carol A. Ross Board Secretary	William Koester Administrative Chairperson





**Department of Commerce**

Division of Industrial Compliance  
Ohio Construction Industry  
Licensing Board O.C.I.L.B.

Mike DeWine  
Sheryl Maxfield

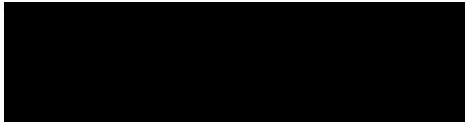
STEWART, PHIL



Mike DeWine Governor	Sheryl Maxfield Director
	
Ohio License # 18276	Expiration Date: 09/30/2023
<b>PHIL A STEWART</b> <b>BASS HEATING, COOLING and PLUMBING</b> <b>OWNER</b>	
<i>Carol Ross</i>	<i>William Koester</i>
Carol A. Ross Board Secretary	William Koester Administrative Chairperson

This is YOUR license. Plan Approvals obtained with YOUR license and posting of YOUR license indicates that YOU and YOUR liability insurance are assuming all responsibility for any projects performed under this license.

Mike DeWine Governor	Sheryl Maxfield Director
LICENSE MUST BE POSTED ON JOB SITE	LICENSE MUST BE POSTED ON JOB SITE
	
<b>HVAC</b> <b>CONTRACTOR'S LICENSE</b> <b>PHIL A STEWART</b> <b>BASS HEATING, COOLING and PLUMBING</b> <b>OWNER</b> Ohio License# 18276 Expiration Date: <b>September 30, 2023</b>	
<i>Carol Ross</i>	<i>William Koester</i>
Carol A. Ross Board Secretary	William Koester Administrative Chairperson



**Department of Commerce**

Division of Industrial Compliance  
Ohio Construction Industry  
Licensing Board O.C.I.L.B.

Mike DeWine  
Sheryl Maxfield

STEWART, PHIL



Mike DeWine Governor  
Sheryl Maxfield Director

Ohio License # 18276 Expiration Date: 09/30/2022

PHIL A STEWART  
STEWART ELECTRIC  
OWNER

Carol A. Ross Board Secretary  
William Koester Administrative Chairperson

This is YOUR license. Plan Approvals obtained with YOUR license and posting of YOUR license indicates that YOU and YOUR liability insurance are assuming all responsibility for any projects performed under this license.

Mike DeWine Governor  
Sheryl Maxfield Director

LICENSE MUST BE POSTED ON JOB SITE

LICENSE MUST BE POSTED ON JOB SITE

OHIO CONSTRUCTION INDUSTRY LICENSING BOARD

**Electrical**  
CONTRACTOR'S LICENSE  
**PHIL A STEWART**  
STEWART ELECTRIC  
OWNER

Ohio License# 18276

Expiration Date: **September 30, 2022**

STATE OF OHIO

Carol A. Ross Board Secretary  
William Koester Administrative Chairperson

**File Attachments for Item:**

C-11 Wagner, William - BO

Certification ID# 5739

Current certifications- BI, RBI, RBO

**Board of Building Standards**

Application for Interim Certification, Building Department Personnel

Wagner

William

5739

Last Name

First Name

BBS Certification ID

**SECTION 1: CHECK INTERIM CERTIFICATION(S) BEING REQUESTED**

<input checked="" type="checkbox"/> Building Official	<input type="checkbox"/> Master Plans Examiner	<input type="checkbox"/> Building Inspector	<input type="checkbox"/> Electrical Safety Inspector	<input type="checkbox"/> Fire Protection Inspector
<input type="checkbox"/> Building Plans Examiner	<input type="checkbox"/> Plumbing Plans Examiner	<input type="checkbox"/> Mechanical Plans Examiner	<input type="checkbox"/> Electrical Plans Examiner	<input type="checkbox"/> Fire Protection Plans Examiner
	<input type="checkbox"/> Plumbing Inspector	<input type="checkbox"/> Mechanical Inspector	<input type="checkbox"/> Non-Residential Industrial Unit Inspector	

**SECTION 2: LIST ANY OHIO LICENSE, CERTIFICATE, OR REGISTRATION HELD**

(Mark "T" If Trainee)

Description		Certificate Number	Date Received
Architectural Registration			
P.E. Registration			
Res	Non-Res		
<input checked="" type="checkbox"/>	<input type="checkbox"/>	Building Official Certification	5739
<input type="checkbox"/>	<input type="checkbox"/>	Plans Examiner Certification	
<input checked="" type="checkbox"/>	<input checked="" type="checkbox"/>	Building Inspector Certification	5739
<input type="checkbox"/>	<input type="checkbox"/>	Mechanical Inspector Certification	
Building Plans Examiner Certification			
Mechanical Plans Examiner Certification			
Fire Protection Plans Examiner Certification			
Electrical Plans Examiner Certification			
Plumbing Plans Examiner Certification			
Fire Protection Inspector Certification			
Electrical Safety Inspector Certification			
Plumbing Inspector Certification			
Fire Safety Inspector Certification			
Fire Protection System Designer Certification			
Medical Gas Piping Inspector Certification			

William

*Last Name*

Wagner

*First Name*

5739

*BBS Certification ID*

**SECTION 3: EMPLOYMENT/EDUCATION**

Formal Education	Date Graduated
Lakewood High School	2000
Related Vocational or Technical Training	Years' Experience
NEOJATC, Carpenters training center	4yr apprenticeship
U.S. Military construction experience (MOS or other designation):	Years' Experience
Place of Employment:	Years' Employed
City of Lakewood Building Department	5 Years

**SECTION 4: APPLICANTS REQUESTING MEDICAL GAS INSPECTOR CERTIFICATION**

*Attach proof of certification by an ASSE recognized third-party certifier in accordance with ASSE standard 6020.*

**SECTION 5: OBC BUILDING INSPECTION EXPERIENCE PERFORMED FOR A BBS CERTIFIED BUILDING DEPARTMENT**

BBS Certified Building Department	BBS Certified Position/Title	Duties	Date of Service, Length of Time (MM/DD/YY)
City of Lakewood Building Department	Residential Building Official (back-up)	Back-up RBO for Chris Parmelee (Current CBO)	2019-2021
City of Lakewood Building Department	Residential Building Official, Assitant Building Commissioner	Residential plans examiner, BZA (zoning) appeals	2021-Present
City of Lakewood Building Department	Residential and Non-Residential Building Inspector	Interior and exterior structural framing, fire barriers, sheathing, thermal envelope, mechanical, etc.	2017-Present

Wagner  
Last Name

William  
First Name

5739  
BBS Certification ID

**SECTION 6: ELECTRICAL SAFETY INSPECTOR (ESI) - SPECIFIC EXPERIENCE QUALIFICATIONS**

Applicants for Electrical Safety Inspector Only Must Complete This Item

Section 3783 of the Ohio Revised Code specifies that an applicant for a Certificate of Competency as an Electrical Safety Inspector must meet one of the following to qualify to take required examination. Please check the qualification that applies:

1.  Have been a journeyman electrician or equivalent for four years, two of which were as an electrician foreman, and have had two years' experience as a building department electrical inspector trainee;
2.  Have been a journeyman electrician or equivalent for four years and have had three years' experience as a building department electrical inspector trainee;
3.  Have had for four years' experience as a building department electrical inspector trainee;
4.  Have been a journeyman electrician or equivalent for six years;
5.  Am a graduate electrical engineer and registered in the State of Ohio. Registration number: \_\_\_\_\_
6.  Applicant authorizes all testing organizations including ICC to provide test results to the BBS.

**SECTION 7: EXPERIENCE (DO NOT SUBSTITUTE WITH OTHER RESUMES).**

Refer to Experience Requirements Listed in O.A.C. 4101:7-3-01 and O.R.C. 3783

Below, list the specific projects you worked on, and the specific work you performed, your typical duties for each project, and dates of this work. You **must** demonstrate that you have the required number of months (years) of actual, practical experience for the certification requested (see matrix).

Provide letters from certified inspectors, employers, or contractors verifying your experience. Submit copies of any certificates, diplomas, or licenses. Remove all personal information.

**SECTION 7 CONT.: EXPERIENCE**

List Each Construction Project <u>AND</u> Specific Type of Work Performed	Name of Employer, Contact, Address, Telephone Number	Project Time: From _ To _ (MM/YY)
<i>Example: Children's Hospital, Toledo Structural steel work on addition</i>	<i>Homer Steel and Trade 125 Anytown Street My City, OH, 45454 (419)555-1212</i>	<i>July 2013-May 2014 (10 months)</i>
Total Experience on This Page (In Months):		<i>92 months</i>



Board of Building Standards Application for Interim Certification, Building Department Personnel

Project and work performed	Employer name and contact info	Project time
<b>St. Mary of the Woods</b> Structural wood and metal framing, drywall, ceiling grid, layout	<b>MJS Interiors</b> Mike Strano (owner) 440.248.0808	04/01/2006-02/01/2007
<b>Bed Bath &amp; Beyond</b> Structural metal framing, sheathing and drywall	" "	05/01/2007-09/01/2007
<b>Hummer Dealership</b> Structural metal framing	" "	10/07/2007-12/01/2007
<b>Gilmore Academy Rink</b> Demo, structural and partition wall metal framing, drywall and cement board	" "	02/01/2008-05/01/2008
<b>Cleveland Clinic Pharmacy</b> Print reading, layout, structural metal framing, drywall, grid ceilings	Marous Brothers Const. 1702 Joseph Lloyd Pkwy Willoughby, Ohio 44094 440.951.2904	02/01/2009-07/01/2009
<b>Tremont Point Apartments</b> Structural wood framing, rigging, sheathing, layout and stair construction	" "	07/01/2008-02/01/2009
<b>University Hospital NICU</b> Layout, print reading, structural and partition wall steel framing, fire barrier const, doors and hardware	" "	07/01/2009-01/01/2010
<b>Case Western Reserve Alumni House</b> Wood structural framing, exterior finish	" "	05/01/2009-06/01/2009
		<b>Total experience months- 38 Months</b>

Board of Building Standards Application for Interim Certification, Building Department Personnel

Project and work performed	Employer name and contact info	Project time
<b>East Ohio Gas Comp Cred Union</b> Handrail, doors and hardware, cabinets, countertops	Fred Oliveri Const. 6315 Promway Ave. NW North Canton, Ohio 44720	07/01/2009-10/30/2009
<b>TriPoint Medical Center</b> Exterior steel structural framing, interior partition wall framing, sheathing, drywall, fire walls	OCP Contractors 21863 Aurora Road Bedford Heights, Ohio 44146 440.951.9727	04/01/2010-10/01/2010
<b>Cleveland State</b> Exterior structural steel framing	" "	10/01/2010-10/01/2010
<b>Lorain Community College</b> Exterior structural steel, interior steel partition walls, interior shaft/fire barriers, drop ceilings, drywall, layout and print reading	Roger Kreps 8065 Market St Youngstown, Ohio 44512 330.726.6080	04/01/2011-12/01/2011
<b>Rocky River High school reno</b> Foreman, structural exterior/interior steel, partition and fire wall/barriers, drop ceilings, direct communication with GC and Owner	" "	05/01/2012-06/01/2013
<b>Victoria's Sec remod</b> Foreman, structural and partition wall steel, drywall and drop ceiling	Vine Interiors Chagrin Falls, Ohio 44023 440.226.1353	05/01/2015-08/01/2015
<b>Holiday Inn</b> <b>8650 Euclid Ave</b> Lead Carpenter, ext. structural steel, interior fire rated shaft, ceiling framing, parapet const. and sheathing	Competitive Interiors 6251 Gladys St Ravenna, Ohio 44266	09/01/2015-02/01/2016
		<b>Total experience months- 41 Months</b>



**Board of Building Standards**

Application for Interim Certification, Building Department Personnel

Wagner  
Last Name

William  
First Name

5939  
BBS Certification ID

**SECTION 8: PERSONAL HISTORY**

- 1. Have you ever been convicted of any felony, or any crime involving moral turpitude?  
 Yes  No

If you answered "Yes" please explain below:

- 2. Have you served in the U.S. armed services? (If No, skip question 3)  Yes  No
- 3. If YES, were you discharged under honorable conditions?  Yes  No

If you answered "No" please explain below:

**SECTION 9: CERTIFICATION**

I certify the information contained in this application is true and complete, and I understand that providing false information may be grounds for not granting certification or for immediate termination of certification at any point in the future, if granted. I authorize the investigation of all statements contained herein and release all parties from all liability for any damage that may result from furnishing the same to Ohio Board of Building Standards. Falsification is a violation of section 2921.13 of the Ohio Revised Code and is punishable as a misdemeanor of the first degree.

Signature of Applicant: *William Wagner*

Subscribed and duly sworn before me according to law, by the above named applicant this day 9 of September in the year 2022 at Lakewood, County of Cuyahoga and State of Ohio.

Notary Public: *Diana Graff*



DIANA GRAFF  
Notary Public  
State of Ohio  
My Comm. Expires  
January 3, 2027

STATE OF OHIO

# Certificate of Completion of Apprenticeship

ISSUED BY  
THE OHIO STATE APPRENTICESHIP COUNCIL

This is to certify that: WILLIAM WAGNER  
has fulfilled the terms of the apprenticeship agreement in accordance with the registered standards and requirements, with related instruction and is hereby recognized and qualified as a journeyperson  
CARPENTER

together with all the rights, privileges and opportunities which everywhere pertain thereto.

In testimony Whereof, the Ohio State Apprenticeship Council of the Ohio Department of Job and Family Services in cooperation with the Bureau of Apprenticeship and Training, U.S. Department of Labor, do affix the Great Seal of the State of Ohio.

Witnessed Over Our Signatures and Seal:



Sponsored by:

NEO Carpenters' JATC

Richfield, OH

R.W. Crossman  
Chairman

Given at Columbus in the State of Ohio,

this 1st day of January A.D. 2010

[Signature]  
DIRECTOR, OHIO STATE APPRENTICESHIP COUNCIL

[Signature]  
CHAIRMAN, OHIO STATE APPRENTICESHIP COUNCIL

TED STRICKLAND  
GOVERNOR OF OHIO



**CARPENTERS  
INTERNATIONAL  
TRAINING  
FUND**



Certificate of Completion to certify that

**William A. Wagner**

Has successfully completed the training requirements of the "UBC/Hytorc Bolting Technician Qualification" program. This training was developed by the UBC/Hytorc Bolting Technician Qualification Partnership

**12/20/2008 - 12/20/2008**

Class Dates

*William K. Lewis, Jr.*

Executive Director

**U-2895-9770**

UBC #

**Joseph K Horrigan**

Instructor





**CARPENTERS  
INTERNATIONAL  
TRAINING  
FUND**



Certificate of Completion to certify that

**William A. Wagner**

Has completed the training and testing requirements of the UBC Rigging Qualification Program. This training meets or exceeds the requirements of ANSI A10.42-2000.

10/28/2008 - 11/08/2008

Class Dates

11/30/2012

Expiration Date

U-2895-9770

UBC #

*William K. Irving, Jr.*

Executive Director

Patrick T Butterfield

Instructor





**CIVIL SERVICE COMMISSION**  
12650 Detroit Avenue • Lakewood, Ohio 44107  
216/529-6040 • FAX 216/228-2514  
Website: [www.onelakewood.com](http://www.onelakewood.com)  
Email: [civilservice@lakewoodoh.net](mailto:civilservice@lakewoodoh.net)

June 18, 2021

William Wagner  
1321 Bunts Road  
Lakewood, OH 44107

Sent via e-mail: [William.wagner@lakewoodoh.net](mailto:William.wagner@lakewoodoh.net)

Dear William:

This is to advise you that your score on the non-competitive, oral exam held June 9, 2021, for the position of Assistant Building Commissioner is 91%. Your name has been certified to the appointing authority. I will contact Shawn Leininger and have him work with Human Resources to update your change in status.

Congratulations!

BY ORDER OF THE COMMISSION

Patricia Donovan

cc: Shawn Leininger  
Human Resources





DIVISION OF HOUSING AND BUILDING  
12650 DETROIT AVENUE • LAKEWOOD, OHIO 44107 • 216/529-6270 • FAX 216/529-5930  
Website: [www.onelakewood.com](http://www.onelakewood.com)

MAIN (216) 529-6270  
FAX (216) 529-5930

[building.permits@lakewoodoh.net](mailto:building.permits@lakewoodoh.net)  
[www.onelakewood.com](http://www.onelakewood.com)

9/1/2022

To whom it may concern,

William Wagner has proven himself to be an effective leader as our Residential Building Official and will carry the same leadership as my CBO backup, and eventually CBO of his own department. Our industry is in dire need of qualified individuals that are ready to serve communities for years to come. Since his time here he has been a residential building inspector, commercial building inspector, our residential building Official, and acts as my Assistant Building Commissioner for administrative duties. I ask that you thoughtfully consider William's application for Certified Building Official. This will not only assist my office but our industry as a whole.

Thank You,

Christopher S. Parmelee  
Building Commissioner BBS# 4985  
(216)529-6295  
[Christopher.parmelee@lakewoodoh.net](mailto:Christopher.parmelee@lakewoodoh.net)

**File Attachments for Item:**

C-12 Wright, Charles - NRIUI

Cert ID: 5488

Current Certifications: RIUI

**SECTION 1: CHECK INTERIM CERTIFICATION(S) BEING REQUESTED**

<input type="checkbox"/> Building Official	<input type="checkbox"/> Master Plans Examiner	<input type="checkbox"/> Building Inspector	<input type="checkbox"/> Electrical Safety Inspector	<input type="checkbox"/> Fire Protection Inspector
<input type="checkbox"/> Building Plans Examiner	<input type="checkbox"/> Plumbing Plans Examiner	<input type="checkbox"/> Mechanical Plans Examiner	<input type="checkbox"/> Electrical Plans Examiner	<input type="checkbox"/> Fire Protection Plans Examiner
	<input type="checkbox"/> Plumbing Inspector	<input type="checkbox"/> Mechanical Inspector	<input checked="" type="checkbox"/> Non-Residential Industrial Unit Inspector	

**SECTION 2: LIST ANY OHIO LICENSE, CERTIFICATE, OR REGISTRATION HELD**

(Mark "T" If Trainee)

Description		Certificate Number	Date Received
Architectural Registration			
P.E. Registration			
Res	Non-Res		
<input type="checkbox"/>	<input type="checkbox"/>	Building Official Certification	
<input type="checkbox"/>	<input type="checkbox"/>	Plans Examiner Certification	
<input type="checkbox"/>	<input type="checkbox"/>	Building Inspector Certification	
<input type="checkbox"/>	<input type="checkbox"/>	Mechanical Inspector Certification	
Building Plans Examiner Certification			
Mechanical Plans Examiner Certification			
Fire Protection Plans Examiner Certification			
Electrical Plans Examiner Certification			
Plumbing Plans Examiner Certification			
Fire Protection Inspector Certification			
Electrical Safety Inspector Certification			
Plumbing Inspector Certification			
Fire Safety Inspector Certification			
Fire Protection System Designer Certification			
Medical Gas Piping Inspector Certification			

**SECTION 3: EMPLOYMENT/EDUCATION**

Formal Education	Date Graduated
Peru High School	5/1982
Related Vocational or Technical Training	Years' Experience
U.S. Military construction experience (MOS or other designation):	Years' Experience
Place of Employment:	Years' Employed
National Electrical Contractor	8
T.R.Arnold and Associates, Inc.	6+

**SECTION 4: APPLICANTS REQUESTING MEDICAL GAS INSPECTOR CERTIFICATION**

*Attach proof of certification by an ASSE recognized third-party certifier in accordance with ASSE standard 6020.*

**SECTION 5: OBC BUILDING INSPECTION EXPERIENCE PERFORMED FOR A BBS CERTIFIED BUILDING DEPARTMENT**

BBS Certified Building Department	BBS Certified Position/Title	Duties	Date of Service, Length of Time (MM/DD/YY)

**Board of Building Standards**

Application for Interim Certification, Building Department Personnel

Wright  
Last Name

Charles  
First Name

5488  
BBS Certification ID

**SECTION 6: ELECTRICAL SAFETY INSPECTOR (ESI) - SPECIFIC EXPERIENCE QUALIFICATIONS**

Applicants for Electrical Safety Inspector Only Must Complete This Item

Section 3783 of the Ohio Revised Code specifies that an applicant for a Certificate of Competency as an Electrical Safety Inspector must meet one of the following to qualify to take required examination. Please check the qualification that applies:

1.  Have been a journeyman electrician or equivalent for four years, two of which were as an electrician foreman, and have had two years' experience as a building department electrical inspector trainee;
2.  Have been a journeyman electrician or equivalent for four years and have had three years' experience as a building department electrical inspector trainee;
3.  Have had for four years' experience as a building department electrical inspector trainee;
4.  Have been a journeyman electrician or equivalent for six years;
5.  Am a graduate electrical engineer and registered in the State of Ohio. Registration number: \_\_\_\_\_
6.  Applicant authorizes all testing organizations including ICC to provide test results to the BBS.

**SECTION 7: EXPERIENCE (DO NOT SUBSTITUTE WITH OTHER RESUMES).**

Refer to Experience Requirements Listed in O.A.C. 4101:7-3-01 and O.R.C. 3783

Below, list the specific projects you worked on, and the specific work you performed, your typical duties for each project, and dates of this work. You **must** demonstrate that you have the required number of months (years) of actual, practical experience for the certification requested (see matrix).

Provide letters from certified inspectors, employers, or contractors verifying your experience. Submit copies of any certificates, diplomas, or licenses. Remove all personal information.

**SECTION 7 CONT.: EXPERIENCE**

List Each Construction Project <b>AND</b> Specific Type of Work Performed	Name of Employer, Contact, Address, Telephone Number	Project Time: From_ To _ (MM/YY)
<i>Example:</i> Children's Hospital, Toledo Structural steel work on addition	Homer Steel and Trade 125 Anytown Street My City, OH, 45454 (419)555-1212	July 2013-May 2014 (10 months)
Commerical, Residential and RV inspections.	T.R.Arnold and Associates, Inc. 4703 Chester Drive Elkhart, IN 46516	JAN. 2016 - Present
<b>Total Experience on This Page (In Months):</b>		72+

List Each Construction Project <u>AND</u> Specific Type of Work Performed	Name of Employer, Contact, Address, Telephone Number	Project Time: From_ To _ (MM/YY)
<b>Total Experience on This Page (In Months):</b>		

Wright

Charles

5488

Last Name

First Name

BBS Certification ID

SECTION 8: PERSONAL HISTORY

1. Have you ever been convicted of any felony, or any crime involving moral turpitude?

Yes  No

If you answered "Yes" please explain below:

2. Have you served in the U.S. armed services? (If No, skip question 3)

Yes  No

3. If YES, were you discharged under honorable conditions?

Yes  No

If you answered "No" please explain below:

Empty table for explanation of "No" answers.

SECTION 9: CERTIFICATION

I certify the information contained in this application is true and complete, and I understand that providing false information may be grounds for not granting certification or for immediate termination of certification at any point in the future, if granted. I authorize the investigation of all statements contained herein and release all parties from all liability for any damage that may result from furnishing the same to Ohio Board of Building Standards. Falsification is a violation of section 2921.13 of the Ohio Revised Code and is punishable as a misdemeanor of the first degree.

Signature of Applicant:

Handwritten signature of Charles Wright.

Subscribed and duly sworn before me according to law, by the above named applicant this

day 6th of September in the year 2022 at T.R. Arnold & Associates, Inc. County of Elkhart and State of Indiana.

Notary Public:

Handwritten signature of Katherine Healy.

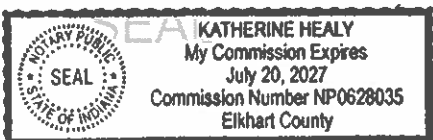



# T.R. ARNOLD & ASSOCIATES, INC.

• Engineering • Plan Review • Inspection •

September 1, 2022

**Subject: Work experience verification for Charles L. Wright**

To Whom It May Concern,

Mr. Wright is personally known to me as an employee of T.R. Arnold & Associates, Inc. (TRA), 4703 Chester Drive, Elkhart, Indiana 46516 during his period of employment from January 2016 to present. TRA is accredited as an independent third party by the International Accreditation Service, the Standards Council of Canada and is recognized throughout the United States by state regulatory bodies for modular units.

Mr. Wright is certified by the International Code Council and numerous modular programs. His duties include inspections and audits of manufactures that construct various residential and commercial modular units. As the President of TRA, direct observation of Mr. Wright in these roles is verified by my personal oversight and I can attest that his performance has been exemplary in all respects.

Please contact me if you need any additional information.

Sincerely,  
T.R. ARNOLD & ASSOCIATES, INC.

Jeffrey A. Clouse, MCP  
President





# INTERNATIONAL CODE COUNCIL

## CHARLES WRIGHT

*The International Code Council attests that the individual named on this certificate has satisfactorily demonstrated knowledge as required by the International Code Council by successfully completing the prescribed written examination based on codes and standards then in effect, and is hereby issued this certification as:*

**Commercial Building Inspector**

*Given this day August 19, 2022*

Handwritten signature of Cindy Davis in black ink.

**Cindy Davis, CBO**  
**President, Board of Directors**

Certificate No. 8410652

Handwritten signature of Dominic Sims in black ink.

**Dominic Sims, CBO**  
**Chief Executive Officer**





# INTERNATIONAL CODE COUNCIL CHARLES WRIGHT

*The International Code Council attests that the individual named on this certificate has satisfactorily demonstrated knowledge as required by the International Code Council by successfully completing the prescribed written examination based on codes and standards then in effect, and is hereby issued this certification as:*

**Commercial Mechanical Inspector**

*Given this day January 20, 2020*

A handwritten signature in black ink, appearing to read "Greg Wheeler".

**Greg Wheeler, CBO**  
**President, Board of Directors**

Certificate No. 8410652

A handwritten signature in black ink, appearing to read "Dominic Sims".

**Dominic Sims, CBO**  
**Chief Executive Officer**





## Verified Candidate

ICC INTERNATIONAL CODE COUNCIL



Search Again

Charles Wright

8410652

### Certifications:

04/06/2016	03/30/2028	Residential Electrical Inspector
05/25/2016	03/30/2028	Residential Combination Inspector
05/10/2016	03/30/2028	Residential Energy Inspector/Plans Examiner
02/23/2016	03/30/2028	Residential Plumbing Inspector
01/30/2016	03/30/2028	Residential Building Inspector
Unknown	03/30/2028	Commercial Energy Inspector
03/07/2016	03/30/2028	Residential Mechanical Inspector
01/20/2020	03/30/2028	Commercial Mechanical Inspector
01/29/2020	03/30/2028	Mechanical Inspector
07/01/2020	03/30/2028	Accessibility Inspector/Plans Examiner
02/08/2021	03/30/2028	Commercial Plumbing Inspector



259

02/09/2021	03/30/2028	Plumbing Inspector
08/19/2022	08/19/2025	Commercial Building Inspector
03/30/2022	03/30/2028	Spray Applied Fire Proofing Special Inspector
08/27/2022	08/27/2025	Building Inspector





# T.R. ARNOLD & ASSOCIATES, INC.

• Engineering • Plan Review • Inspection •

September 6, 2022

Amy Jones  
Ohio Board of Building Standards  
6606 Tussing Road  
P.O. Box 4009  
Reynoldsburg, OH 43068-9009

Subject: New Application – Charles Wright

Dear Ms. Jones,

Enclosed is an application for Charles Wright. Also enclosed is a check in the amount of \$50.00 to cover the application fee.

Thank you for your time and consideration in this matter. Please don't hesitate to contact our office if you need anything further.

Sincerely,  
T.R. ARNOLD & ASSOCIATES, INC.

Kate  
Healy

Digitally signed by  
Kate Healy  
Date: 2022.09.06  
14:39:55 -04'00'

Kate Healy  
Accounts Coordinator

**File Attachments for Item:**

C-13 Capra, Roddy - RBO

Cert ID:

Current Certifications:

# Board of Building Standards

Application for Trainee Certification, Building Department Personnel

CAPRA

Last Name

Roddy

First Name

BBS Certification ID

## SECTION 1: CHECK TRAINEE CERTIFICATION(S) BEING REQUESTED

<input checked="" type="checkbox"/> Building Official	<input type="checkbox"/> Master Plans Examiner	<input type="checkbox"/> Building Inspector	<input type="checkbox"/> Electrical Safety Inspector	<input type="checkbox"/> Fire Protection Inspector
<input type="checkbox"/> Building Plans Examiner	<input type="checkbox"/> Plumbing Plans Examiner	<input type="checkbox"/> Mechanical Plans Examiner	<input type="checkbox"/> Electrical Plans Examiner	<input type="checkbox"/> Fire Protection Plans Examiner
	<input type="checkbox"/> Plumbing Inspector	<input type="checkbox"/> Mechanical Inspector	<input type="checkbox"/> Non-Residential Industrial Unit Inspector	

<input type="checkbox"/> Res. Building Official	<input type="checkbox"/> Res. Plans Examiner	<input type="checkbox"/> Res. Building Inspector
	<input type="checkbox"/> Res. Industrial Unit Inspector	<input type="checkbox"/> Res. Mechanical Inspector

## SECTION 2: LIST ANY OHIO LICENSE, CERTIFICATE, OR REGISTRATION HELD

(Mark "T" If Trainee)

Description		Certificate Number	Date Received
Architectural Registration			
P.E. Registration			
Res	Non-Res		
<input type="checkbox"/>	<input type="checkbox"/>	Building Official Certification	
<input type="checkbox"/>	<input type="checkbox"/>	Plans Examiner Certification	
<input type="checkbox"/>	<input type="checkbox"/>	Building Inspector Certification	
<input type="checkbox"/>	<input type="checkbox"/>	Mechanical Inspector Certification	
Building Plans Examiner Certification			
Mechanical Plans Examiner Certification			
Fire Protection Plans Examiner Certification			
Electrical Plans Examiner Certification			
Plumbing Plans Examiner Certification			
Fire Protection Inspector Certification			
Electrical Safety Inspector Certification			
Plumbing Inspector Certification			
Fire Safety Inspector Certification			
Fire Protection System Designer Certification			
Medical Gas Piping Inspector Certification			

## Section 3: Employment/Education

a. Formal Education	Date Graduated

# Board of Building Standards

Application for Trainee Certification, Building Department Personnel

CAPRA  
Last Name

Roddy  
First Name

\_\_\_\_\_  
BBS Certification ID

b. Related Vocational or Technical Training	Years' Experience
c. U.S. Military construction experience (MOS or other designation):	Years' Experience
d. Place of Employment:	Years' Employed

## SECTION 4: OBC/RCO BUILDING INSPECTION EXPERIENCE PERFORMED FOR A BBS CERTIFIED BUILDING DEPARTMENT

BBS Certified Building Department	BBS Certified Position/Title	Duties	Date of Service, Length of Time (MM/DD/YY)

## SECTION 5: EXPERIENCE (DO NOT SUBSTITUTE WITH OTHER RESUMES).

Refer to Experience Requirements Listed in O.A.C. 4101:7-3-01 and O.R.C. 3783

Below, list the specific projects you worked on, and the specific work you performed, your typical duties for each project, and dates of this work. You must demonstrate that you have the required number of months (years) of actual, practical experience for the certification requested (see matrix).

Provide letters from certified inspectors, employers, or contractors verifying your experience. Submit copies of any certificates, diplomas, or licenses. Remove all personal information.

List Each Construction Project <u>AND</u> Specific Type of Work Performed	Name of Employer, Contact, Address, Telephone Number	Project Time: From_ To _ (MM/YY)
<i>Example: Children's Hospital, Toledo Structural steel work on addition</i>	<i>Homer Steel and Trade 125 Anytown Street My City, OH, 45454 (419)555-1212</i>	<i>July 2013-May 2014 (10 months)</i>
Total Experience on This Page (In Months):		



**Board of Building Standards**

Application for Interim Certification, Building Department Personnel

CAPRA

Last Name

Roddy

First Name

BBS Certification ID

**SECTION 5 CONT.: EXPERIENCE**

List Each Construction Project <u>AND</u> Specific Type of Work Performed	Name of Employer, Contact, Address, Telephone Number	Project Time: From _ To _ (MM/YY)
<p>NEW HOME CONSTRUCTION Multiple Homes - Finish CARPENTRY, Plumbing, Electrical, Tiling, PAINTING, Rough Framing, Rough in for Plumbing, Electrical, HVAC. ATTENDED city + county INSPECTIONS Observed, EXCAVATION, Foundations, and all PHASES OF CONSTRUCTION</p>	<p>CAPRA INDUSTRIES 29007 Anderson Rd. Wickliffe, OH 44092 Linn CAPRA / Pasquale CAPRA NO LONGER IN BUSINESS</p>	<p>01/98 - 05/08</p>
<p>Remodeling - Kitchens, Baths, Additions - (Laborer)</p>	<p>N.J.P. CONSTRUCTION 9100 Tyler Blvd. Menton, OH 44066 Nick PETRO (440) 578-1056</p>	<p>06/08 - 06/09</p>
<p>Remodeling, Rehab, Handyman work Kitchens, Bathrooms, Tiling, Siding REPAIR, ETC.</p>	<p>Self-Employed 1841 Eldon Dr. Wickliffe, OH 44092 (440) 537-1775</p>	<p>06/09 - 05/22</p>
<p>Property Maintenance + Zoning Enforcement</p>	<p>CITY OF EASTLAKE, OHIO 35150 Lakeshore Blvd. Eastlake, OH 44095 (440) 951-2200 x.1008 David MENN</p>	<p>05/22 - CURRENT</p>
<p><b>Total Experience on This Page (In Months):</b></p>		

**Board of Building Standards**

Application for Trainee Certification, Building Department Personnel

CAPRA  
Last Name

Roddy  
First Name

\_\_\_\_\_  
BBS Certification ID

**SECTION 6: PERSONAL HISTORY**

- 1. Have you ever been convicted of any felony, or any crime involving moral turpitude?  
If you answered "Yes" please explain below:  Yes  No
- 2. Have you served in the U.S. armed services? (If No, skip question 3)  Yes  No
- 3. If YES, were you discharged under honorable conditions?  
If you answered "No" please explain below:  Yes  No

**SECTION 7: CERTIFICATION**

*I certify the information contained in this application is true and complete, and I understand that providing false information may be grounds for not granting certification or for immediate termination of certification at any point in the future, if granted. I authorize the investigation of all statements contained herein and release all parties from all liability for any damage that may result from furnishing the same to Ohio Board of Building Standards. Falsification is a violation of section 2921.13 of the Ohio Revised Code and is punishable as a misdemeanor of the first degree.*

Signature of Applicant: 

Subscribed and duly sworn before me according to law, by the above named applicant this day 13<sup>th</sup> of Sept. in the year 2022 at East Lake, County of Lake and State of Ohio.

Notary Public: 

SEAL



CAROLYN SNYDER-BRANDAIS  
Notary Public, State of Ohio  
My Commission Expires  
April 7, 2025

CAPRA  
Last Name

Roddy  
First Name

\_\_\_\_\_  
BBS Certification ID

**SUPERVISOR CERTIFICATION OF TRAINEE**

*Please complete this certification and return it with the BBS Application for Trainee Certification.*

Application for participation in a BBS trainee program is being made to the Board of Building Standards. I, DAVID MENDO trainee supervisor for the political subdivision of CITY OF EASTLAKE, (Municipality, Township, County) hold certification as a C.B.O, Certification ID# 983, effective until 2024, and hereby consent and agree to supervise the work of Roddy Capra (Applicant) as a Building Department Trainee pursuant to section 4101:7-3-01(F)(5)(b) of the Ohio Administrative Code.

Number of Trainees presently supervised (including this applicant):

One  Two

Signature: [Signature] Date: 9-14-22

CAPRA  
Last Name

Roddy  
First Name

\_\_\_\_\_  
BBS Certification ID

**BUILDING OFFICIAL CERTIFICATION OF  
TRAINEE AND SUPERVISOR**

*Please complete this certification and return it with the BBS Application for Trainee Certification*

Application for participation in a BBS Trainee program is being made to the Board of Building Standards. I, DAVID MENN, Building Official for the political subdivision of CITY OF EASTLAKE (Municipality, Township, County) do hereby acknowledge that the applicant, Roddy Capra, and the assigned supervisor, DAVID MENN are full-time employees of the above mentioned political subdivision.

Signature:  Date: 9-14-22

**File Attachments for Item:**

C-14 Wallace, Brandy - RIUI

Cert ID:

Current Certifications: None

**Board of Building Standards**

Wallace

Last Name

Application for Interim Certification, Building Department Personnel

Brandy

First Name

BBS Certification ID

**SECTION 1: CHECK INTERIM CERTIFICATION(S) BEING REQUESTED**

<input type="checkbox"/> Res. Building Official	<input type="checkbox"/> Res. Plans Examiner	<input type="checkbox"/> Res. Building Inspector
	<input checked="" type="checkbox"/> Res. Industrial Unit Inspector	<input type="checkbox"/> Res. Mechanical Inspector

**SECTION 2: LIST ANY OHIO LICENSE, CERTIFICATE, OR REGISTRATION HELD**

(Mark "T" If Trainee)

Description			Certificate Number	Date Received
Architectural Registration				
P.E. Registration				
Res	Non-Res			
<input type="checkbox"/>	<input type="checkbox"/>	Building Official Certification		
<input type="checkbox"/>	<input type="checkbox"/>	Plans Examiner Certification		
<input checked="" type="checkbox"/>	<input type="checkbox"/>	Building Inspector Certification	ICC-R5 . 5298962	December 27, 2006
<input type="checkbox"/>	<input type="checkbox"/>	Mechanical Inspector Certification		
Building Plans Examiner Certification				
Mechanical Plans Examiner Certification				
Fire Protection Plans Examiner Certification				
Electrical Plans Examiner Certification				
Plumbing Plans Examiner Certification				
Fire Protection Inspector Certification				
Electrical Safety Inspector Certification				
Plumbing Inspector Certification				
Fire Safety Inspector Certification				
Fire Protection System Designer Certification				
Medical Gas Piping Inspector Certification				

**Section 3: Employment/Education**

<b>a. Formal Education</b>	<b>Date Graduated</b>
Hutchinson Community College	12/15/2013
<b>b. Related Vocational or Technical Training</b>	<b>Years' Experience</b>
<b>c. U.S. Military construction experience (MOS or other designation):</b>	<b>Years' Experience</b>
<b>d. Place of Employment:</b>	<b>Years' Employed</b>
Twining Consulting dba RADCO inc	2yrs 2 mos

\_\_\_\_\_  
Last Name

\_\_\_\_\_  
First Name

\_\_\_\_\_  
BBS Certification ID

**SECTION 4: OBC/RCO BUILDING INSPECTION EXPERIENCE PERFORMED FOR A BBS CERTIFIED BUILDING DEPARTMENT**

BBS Certified Building Department	BBS Certified Position/Title	Duties	Date of Service, Length of Time (MM/DD/YY)

**SECTION 5: EXPERIENCE (DO NOT SUBSTITUTE WITH OTHER RESUMES).**

*Refer to Experience Requirements Listed in O.A.C. 4101:7-3-01 and O.R.C. 3783*

Below, list the specific projects you worked on, and the specific work you performed, your typical duties for each project, and dates of this work. You must demonstrate that you have the required number of months (years) of actual, practical experience for the certification requested (see matrix).

Provide letters from certified inspectors, employers, or contractors verifying your experience. Submit copies of any certificates, diplomas, or licenses. Remove all personal information.

List Each Construction Project <u>AND</u> Specific Type of Work Performed	Name of Employer, Contact, Address, Telephone Number	Project Time: From_ To _ (MM/YY)
<i>Example:</i> <i>Children's Hospital, Toledo</i> <i>Structural steel work on addition</i>	<i>Homer Steel and Trade</i> <i>125 Anytown Street</i> <i>My City, OH, 45454</i> <i>(419)555-1212</i>	<i>July 2013-May 2014</i> <i>(10 months)</i>
ICC/IBC Industrialized Buildings components, and containers.	PFS 1507 Matt pass Cottage Grove, WI	Nov 2001 - June 2015
ICC/IBC Industrialized Buildings components, and containers.	NTA inc Elkhart, IN	Jan 2009-june 2015
ICC/IBC Industrialized Buildings components, and containers.	RADCO 180171 Mount Washington Fountain Valley, CA	Aug 2020 - Present
<b>Total Experience on This Page (In Months):</b>		

# Board of Building Standards

Application for Interim Certification, Building Department Personnel

Wallace

Brandy

\_\_\_\_\_

Last Name

First Name

BBS Certification ID

## SECTION 6: PERSONAL HISTORY

1. Have you ever been convicted of any felony, or any crime involving moral turpitude?

Yes  No

If you answered "Yes" please explain below:

2. Have you served in the U.S. armed services? (If No, skip question 3)

Yes  No

3. If YES, were you discharged under honorable conditions?

Yes  No

If you answered "No" please explain below:



## SECTION 7: CERTIFICATION

I certify the information contained in this application is true and complete, and I understand that providing false information may be grounds for not granting certification or for immediate termination of certification at any point in the future, if granted. I authorize the investigation of all statements contained herein and release all parties from all liability for any damage that may result from furnishing the same to Ohio Board of Building Standards. Falsification is a violation of section 2921.13 of the Ohio Revised Code and is punishable as a misdemeanor of the first degree.

Signature of Applicant: 

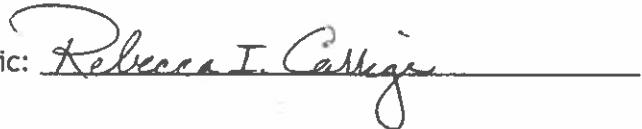
Subscribed and duly sworn before me according to law, by the above named applicant this day 16 of September in the year 2022 at Junction City, County of Geary and State of Kansas.

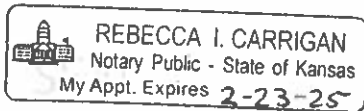
Notary Public: 





**Ohio Board of Building Standards  
Virtual Continuing Education**

8/19/2022

This certifies that

**Brandy Wallace**

Completed the following course(s):

- Certification Basics BBS2022-220 (.5 ceus, all certifications)
- Code Concepts with Steven Regoli \* BBS2022-221 (1.5 ceus, all certifications)
- BBS Web Navigation BBS2022-223 (1 ceu, all certifications)
- Chapter 1 Part 1 \* BBS2022-224 (1.5 ceus, all certifications)
- Chapter 1 Part 2 \* BBS2022-225 (1.5 ceus, all certifications)
- Chapter 34 Part 1 \*\* BBS2022-226 (1.5 ceus, all certifications)
- Chapter 34 Part 2 \*\* BBS2022-227 (1.5 ceus, all certifications)
- ADA and Accessibility BBS2022-228 (1 ceu, all certifications)
- Existing Buildings for Residential \*\* BBS2022-229 (1 ceu, all certifications)
- Energy Code Overview BBS2022-230(1 ceu, all certifications)
- Residential Occupancies BBS2022-231 (1 ceu, all certifications)
- Industrialized Unit Process BBS2022-232 (1 ceu, all certifications)
- BBS Investigations \* BBS2022-233 (1 ceu, all certifications)
- Building Official Breakout with Steve Regoli\* BBS2022-234 (3 ceus, all certifications)
- Plans Examiner Breakout \* BBS2022-235 (3 ceus, all certifications)
- Inspector Breakout \* BBS2022-236 (3 ceus, all certifications)



TIMOTHY P. GALVIN, CHAIRMAN

*Ohio Board of Building Standards*

Approved for all certifications  
HSW: Yes



# INTERNATIONAL CODE COUNCIL

## BRANDY WALLACE

*The International Code Council attests that the individual named on this certificate has satisfactorily demonstrated knowledge as required by the International Code Council by successfully completing the prescribed written examination based on codes and standards then in effect, and is hereby issued this certification as:*

### **Residential Combination Inspector**

*Given this day December 27, 2006*

**Greg Wheeler, CBO**  
**President, Board of Directors**

Certificate No. 5298962

**Dominic Sims, CBO**  
**Chief Executive Officer**

